

DCS GUIDE

FW190-A8 ANTON

By Chuck
LAST UPDATED: 20/09/2023

TABLE OF CONTENTS

- PART 1 – INTRODUCTION
- PART 2 – CONTROLS SETUP
- PART 3 – COCKPIT & EQUIPMENT
- PART 4 – START-UP PROCEDURE
- PART 5 – TAKEOFF
- PART 6 – LANDING
- PART 7 – ENGINE & FUEL MANAGEMENT
- PART 8 – AIRCRAFT LIMITATIONS
- PART 9 – WEAPONS
- PART 10 – RADIO
- PART 11 – NAVIGATION
- PART 12 – AIR COMBAT
- PART 13 – TAMING TAILDRAGGERS



The **Focke-Wulf Fw190 Würger** (English: Shrike) is a German single-seat, single-engine fighter aircraft designed by Kurt Tank in the late 1930s and widely used during World War II. Along with its well-known counterpart, the Messerschmitt Bf.109, the Fw190 became the backbone of the Luftwaffe's Jagdwaffe (Fighter Force). The twin-row BMW 801 radial engine that powered most operational versions enabled the Fw190 to lift larger loads than the Bf.109, allowing its use as a day fighter, fighter-bomber, ground-attack aircraft and, to a lesser degree, night fighter.

Kurt Tank wanted something more than an aircraft only built for speed. He outlined his design philosophy as: *“The Messerschmitt 109 [sic] and the British Spitfire, the two fastest fighters in world at the time we began work on the Fw190, could both be summed up as a very large engine on the front of the smallest possible airframe; in each case armament had been added almost as an afterthought. These designs, both of which admittedly proved successful, could be likened to racehorses: given the right amount of pampering and easy course, they could outrun anything. But the moment the going became tough they were liable to falter. During World War I, I served in the cavalry and in the infantry. I had seen the harsh conditions under which military equipment had to work in wartime. I felt sure that a quite different breed of fighter would also have a place in any future conflict: one that could operate from ill-prepared front-line airfields; one that could be flown and maintained by men who had received only short training; and one that could absorb a reasonable amount of battle damage and still get back. This was the background thinking behind the Focke-Wulf 190; it was not to be a racehorse but a Dienstpferd, a cavalry horse.”*



Kurt Tank
(1898-1983)



The **Focke-Wulf Fw190 Würger** (English: Shrike) is a German single-seat, single-engine fighter aircraft designed by Kurt Tank in the late 1930s and widely used during World War II. Along with its well-known counterpart, the Messerschmitt Bf.109, the Fw190 became the backbone of the Luftwaffe's Jagdwaffe (Fighter Force). The twin-row BMW 801 radial engine that powered most operational versions enabled the Fw190 to lift larger loads than the Bf.109, allowing its use as a day fighter, fighter-bomber, ground-attack aircraft and, to a lesser degree, night fighter.

Kurt Tank wanted something more than an aircraft only built for speed. He outlined his design philosophy as: *“The Messerschmitt 109 [sic] and the British Spitfire, the two fastest fighters in world at the time we began work on the Fw190, could both be summed up as a very large engine on the front of the smallest possible airframe; in each case armament had been added almost as an afterthought. These designs, both of which admittedly proved successful, could be likened to racehorses: given the right amount of pampering and easy course, they could outrun anything. But the moment the going became tough they were liable to falter. During World War I, I served in the cavalry and in the infantry. I had seen the harsh conditions under which military equipment had to work in wartime. I felt sure that a quite different breed of fighter would also have a place in any future conflict: one that could operate from ill-prepared front-line airfields; one that could be flown and maintained by men who had received only short training; and one that could absorb a reasonable amount of battle damage and still get back. This was the background thinking behind the Focke-Wulf 190; it was not to be a racehorse but a Dienstpferd, a cavalry horse.”*



Kurt Tank
(1898-1983)

The Focke-Wulf 190 project began in the summer of 1938. The head of the aircraft design team, Kurt Tank, put forward two proposals: one variant of the aircraft outfitted with a Daimler-Benz DB 601 liquid cooled engine, and a second outfitted with the new air-cooled BMW 139 radial engine. The FW190 V-1 prototype was a cantilevered low-wing aircraft with a stressed-skin wing. Its maiden flight took place on July 1, 1939. The second prototype, the Fw190 V-2, took off in October 1939. This variant was armed with two 13-mm MG 131 machine guns and two MG 17 7.92 mm machine guns. Both aircraft were equipped with large propeller domes which would later on be replaced with NACA propeller domes.

Before the second prototype made its first flight, the decision was made to replace the BMW 139 engine with the more powerful, but longer and heavier BMW 801 engine. This required a large number of major changes to the design: the airframe needed additional structural reinforcement, while the cockpit would have to be moved closer to the tail section of the fuselage. Distancing the cockpit from the engine also solved the aircraft's issues with its center-of-gravity while simultaneously eliminating crew discomfort caused by the engine's noise and heat generation. Another aspect of the new design was the extensive use of electrically powered equipment instead of the hydraulic systems used by most aircraft manufacturers of the time. On the first two prototypes, the main landing gear was hydraulic. Starting with the third prototype, the undercarriage was operated by push buttons controlling electric motors in the wings, and was kept in position by electric up and down-locks. The third and fourth prototypes were not completed, and the Fw190 V5, equipped with the new engine, was built in early 1940. At the end of 1940, the aircraft received a new wing design. The first seven units of the pre-production batch of what became the Fw190 A-0 were outfitted with the original wing, while the rest had the longer wing design. The first combat unit was equipped with these aircraft in August 1941.

The Fw190 participated on every major combat front where the Luftwaffe operated after 1941, and did so with success in a variety of roles. The Fw 190 first tasted combat on the Western Front in August 1941, where it proved superior to the Mk V Spitfire. The Spitfire's main advantage over the Fw190, and the Bf 109 as well, was its superior turn radius. Beyond that, the Fw190 outperformed the Spitfire Mk. V in most areas, such as roll rate, speed, acceleration, and dive performance. This performance mismatch highlighted the urgency for the development of the Spitfire Mk. IX, which was a direct response of the Royal Air Force to this technological gap. The addition of the Fw190 to the Jagdwaffe allowed the Germans to fight off RAF attacks and achieve local air superiority over German skies until the summer of 1942, when the improved Spitfire Mk. IX was introduced. In June 1942, Oberleutnant Armin Faber of JG 2 landed his Fw190 A-3 at a British airfield, allowing the RAF to test the Mk. IX against the 190 and learn tactics to counter it.



In 1942, the Bf.109 began to be partially replaced in Western Europe by the Focke-Wulf; many Bf.109 pilots transitioned to the Fw190. At that time, the Fw190 had greater firepower than the Bf.109 and, at low to medium altitude, superior manoeuvrability, which explains the logic behind this decision. The Fw190 would prove to be a more reliable aircraft, in some respects, than the Bf.109. It handled well on the ground, and its wide undercarriage made it more suited to the often primitive conditions on the Eastern Front (providing an easier and relatively safer takeoff and landing compared to a narrower landing gear). It could also sustain heavier damage than the Bf.109 and survive owing to its radial engine.

The Fw190A series' performance decreased at high altitudes (usually 6,000 m (20,000 ft) and above), which reduced its effectiveness as a high-altitude interceptor. From the Fw190's inception, there had been ongoing efforts to address this with a turbosupercharged BMW 801 in the B model, the much longer-nosed C model with efforts to also turbocharge its chosen Daimler-Benz DB 603 inverted V12 powerplant, and the similarly long-nosed D model with the Junkers Jumo 213. Problems with the turbocharger installations on the -B and -C subtypes meant only the D model would see service, entering service in September 1944. While these "long nose" versions gave them parity with Allied opponents, it arrived far too late in the war to have any real effect. The D-9 series was rarely used against heavy-bomber raids, as the circumstances of the war in late 1944 meant that fighter-versus-fighter combat and ground attack missions took priority.

The Ta152 was a further development of the Fw190 aircraft, and it was intended to be made in at least three versions – the Ta152H *Höhenjäger* ("high-altitude fighter"); the Ta152C designed for medium-altitude operations and ground-attack, using a Daimler-Benz DB 603 and smaller wings; and the Ta152E fighter-reconnaissance aircraft with the engine of the H model and the wing of the C model. The first Ta152H entered service with the Luftwaffe in January 1945. The Ta 152 was produced too late and in insufficient numbers to have a significant role in the war.

Overall, the Fw109 was produced in the following variant “families”:

- A-0: Pre-Production variant
- A1-A9: “Anton” variant, initial production models, used for low to medium altitude in both air-to-air and ground attack roles
- F: “Friedrich” variant, mainly used for ground attack roles.
- G: “Gustav” variant, used for long-range attack missions.
- D: “Dora” variant, used for high altitude with a Junkers Jumo 213 liquid-cooled engine.
- S: re-designated trainers from Anton models.
- Ta152: Late Fw190 variant that was developed after the Dora.

Fw190 Production

Variant	Amount	Years produced
Fw 190 A-1	102	1941 June – 1941 October
Fw 190 A-2/A-3	909	1941 October – 1943 August
Fw 190 A-4	975	1942 June – 1943 August
Fw 190 A-5	1,752	1942 November – 1943 August
Fw 190 A-6	1,052	1943 May – 1944 March
Fw 190 A-7	701	1943 November – 1944 March
Fw 190 A-8	6,655	1944 February – 1945 February
Fw 190 A-9	930	1944 September – 1945 February
Total (including prototypes and pre-production aircraft)	13,291	—
Fw 190 F-1/F-2(A-4)	18 & 271	1942 May – 1943 May
Fw 190 F-3(A-5)	432	1943 May – 1944 April
Fw 190 F-8(A-8)	6,143	1944 March – 1945 February
Fw 190 F-9(A-9)	415	1944 September – 1945 February
Totals	7,279	—
Fw 190 G-1(A-4)	183	1942 August – 1942 November
Fw 190 G-2(A-5)	235	1942 July – 1943 May
Fw 190 G-3(A-6)	214	1943 June – 1943 December
Fw 190 G-8(A-8)	689	1943 August – 1944 February
Totals	approx. 1,300	—
Fw 190 D-9	1,805	1944 August – 1945 April ^[nb 1]
Fw 190 D-11	20	1945 February – 1945 March
Fw 190 D-13	1	1945 April – 1945 April
Totals	1,826	—
Fw 190 S-5 converted from A-5 or built	c. 20	1944 late
Fw 190 S-8 converted from A-8 or built	c. 38	1944 late
Totals	58	—
Ta 152 V/H-0	18/26	1944 December – 1945 January
Ta 152 H-1	25	1945 January – 1945 April
Totals	69	—
Total (all variants)	23,823	—

Records indicate that the majority of Fw190 air victories were achieved in the “A” (also referred as “Anton”) variants since it was the most produced (13,291 Antons vs 1,300 Doras). The Fw190 was well-liked by its pilots. Some of the Luftwaffe's most successful fighter aces claimed a great many of their kills while flying it, including Otto Kittel, Walter Nowotny and Erich Rudorffer. The Luftwaffe had a strong emphasis on tactical innovation and flexibility. Pilots were encouraged to think independently and adapt to changing circumstances, and such thinking is evident in the pilot's biographies written after the war. Most “Jagdgeschwaders” (Fighter Wings) prioritized loose and flexible formations over the ones used for military parades, to great effect.

The first appearance of the Fw190 on the Eastern Front occurred in September 1942. During this time, the Battle of Stalingrad was taking place, which would eventually lead to the destruction of the German Sixth Army. The first German unit to receive the fighter in the east, was Jagdgeschwader 51 (JG 51). However, its I. Gruppe was assigned to the north sector, and undertook operations against the Soviets during the Siege of Leningrad in order to allow the Fw190 to acclimatize. The unit flew free fighter sweeps (*Freie Jagd*). This lasted only days, and I./JG 51 moved southward to Lake Ilmen to provide air cover for the vulnerable Demyansk pocket survivors. In October 1942 the unit moved south again, this time the Rzhev-Vyazma salient. It was at this location the Fw190 started to make an impact.

In December 1942, Jagdgeschwader 54 (JG 54) also began converting on to the Fw190. I./JG 54 would produce the fourth and fifth highest scoring aces of the war. Otto Kittel had scored just 39 victories since the start of Operation Barbarossa, in June 1941. The other was Walter Nowotny. Although he had claimed more than 50 kills on the Bf.109, his success in the Fw190 would see his score rise to 258. Kittel would also go on to achieve 267 victories, all but 39 in the Fw190. The 190 operated in the Eastern Front, Western Front, over Germany, in Africa and in the Mediterranean theaters.



Hans Dortenmann
(1921-1973)
39 Aerial Victories



Heinz Marquardt
(1922-2003)
121 Aerial Victories



Otto Kittel
(1917-1945)
267 Aerial Victories



Walter Nowotny
(1920-1944)
258 Aerial Victories



Erich Rudorffer
(1917-2016)
222 Aerial Victories

In DCS, I realized after a couple of sorties in the FW190 that Kurt was indeed quite right: the ergonomic cockpit layout is a refreshing change from the cluttered interior of the 109 and you can clearly see that the Anton was built as a functional, high-powered war machine. You inevitably feel like you are sitting in a flying tank. And this feeling is pretty awesome.



PART 1 – INTRODUCTION

FW190-A8
ANTON



WHAT YOU NEED MAPPED

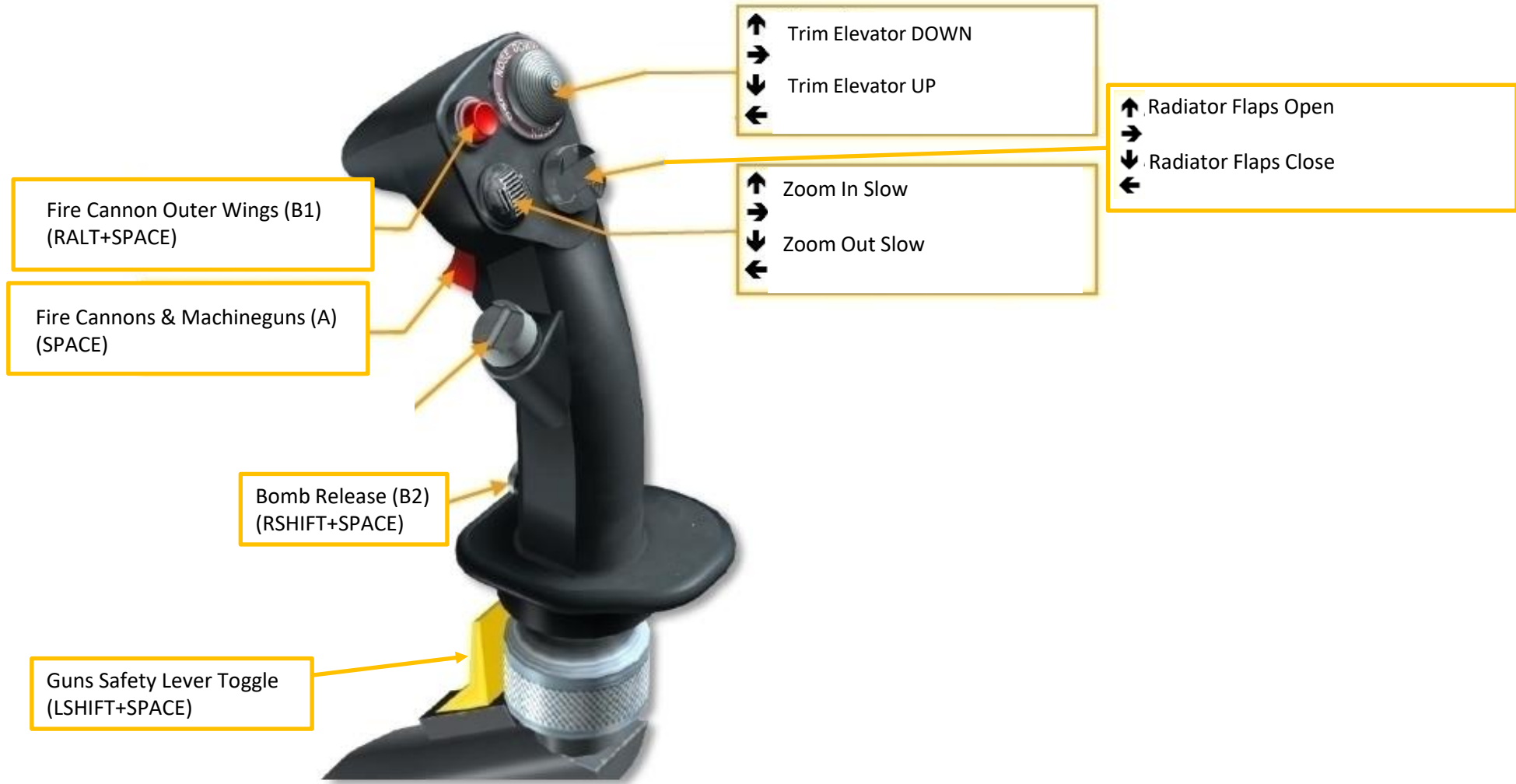

+ TOE BRAKES (MAPPED ON PEDALS)

WHAT YOU NEED MAPPED

-
- ↓ COMM – Push-to-Talk
- ←
- ↑
- P

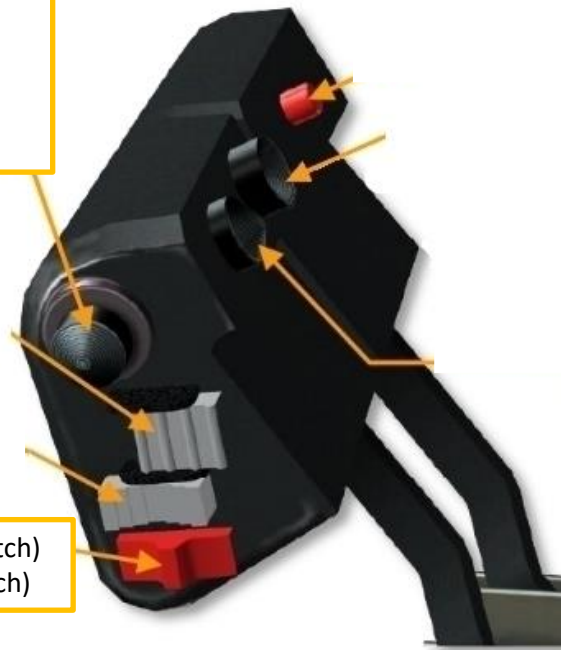

- ← Engine RPM Decrease (Drehzahl, Prop Pitch)
- Engine RPM Increase (Drehzahl, Prop Pitch)

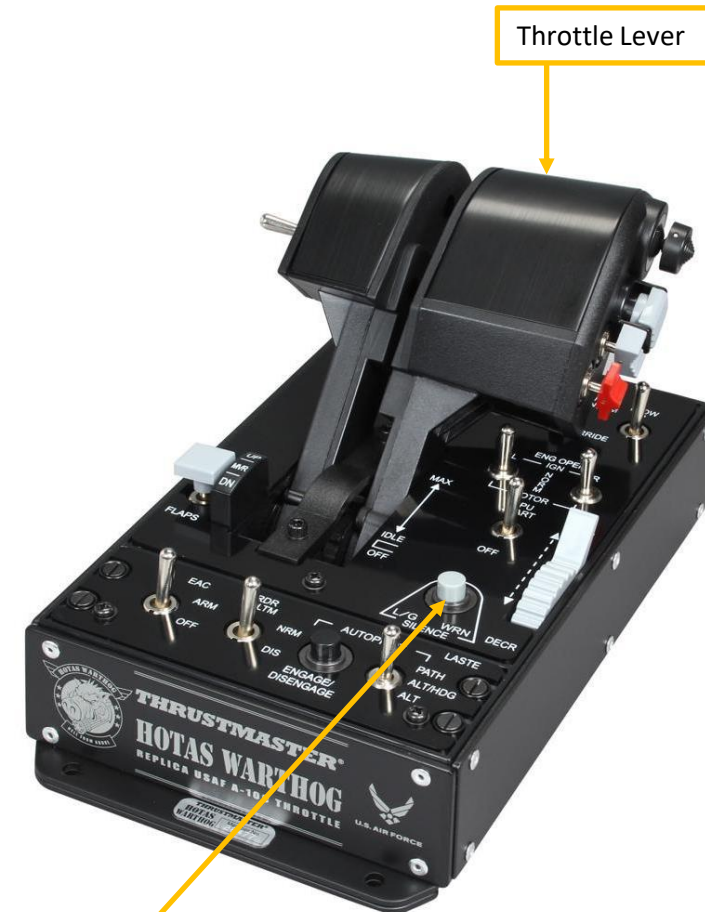

Landing Gear – Up/Down

Bind the following axes:

- Pitch, Roll, Rudder (Deadzone at 0, Saturation X at 100, Saturation Y at 100, Curvature at 0)
- Throttle – Controls Manifold Pressure / Boost / ATA
- Wheel Brake Left
- Wheel Brake Right

AXIS TUNE PANEL

JOY_X

Deadzone: 0

Saturation X: 100

Saturation Y: 100

Curvature: 0

Slider

Invert

User Curve

In: 1 Out: 1

CANCEL RESET OK

When setting wheel brake axis, they are not set to “INVERT” by default. You need to click on INVERT in the Axis Tune menu for each wheel brake.

Action	Category	Keyboard	Throttle - HOTAS Warthog...	Saitek Pro Flight Combat ...	Joystick - HOTAS Warthog ...
Absolute Camera Horizontal View					
Absolute Camera Vertical View					
Absolute Horizontal Shift Camera View					
Absolute Longitude Shift Camera View					
Absolute Roll Shift Camera View					
Absolute Vertical Shift Camera View					
Camera Horizontal View					
Camera Roll View					
Camera Vertical View					
Camera Zoom View					
Canopy Crank					
Clock Turn Scale (analog)	Front Dash				
Gun Sight Brightness (analog)	REVI 16 B Gun Sight				
Head Tracker : Forward/Backward					
Head Tracker : Pitch					
Head Tracker : Right/Left					
Head Tracker : Roll					
Head Tracker : Up/Down					
Head Tracker : Yaw					
Pitch					JOY_Y
Roll					JOY_X
Rudder					JOY_RZ
TDC Slew Horizontal (mouse)					
TDC Slew Vertical (mouse)					
Throttle				JOY_Z	
Wheel Brake					
Wheel Brake Left					JOY_X
Wheel Brake Right					JOY_Y
Zoom View					

OPTIONS

SYSTEM

CONTROLS

GAMEPLAY

MISC.

AUDIO

SPECIAL

VR

Fw 190 A-8

Axis Commands

Foldable view

Reset category to default

Clear category

Clear all

Load profile

Save profile as

Action	Category	Keyboard	Throttle - HOTAS Warthog...	Saitek Pro Flight Combat ...	Joystick - HOTAS Warthog ...	TrackIR	Mouse
Absolute Camera Horizontal View							
Absolute Camera Vertical View							
Absolute Horizontal Shift Camera View							
Absolute Longitude Shift Camera View							
Absolute Roll Shift Camera View							
Absolute Vertical Shift Camera View							
Camera Horizontal View							MOUSE_X
Camera Roll View							
Camera Vertical View							MOUSE_Y
Camera Zoom View							MOUSE_Z
Canopy Crank							
Clock Turn Scale (analog)	Front Dash						
Gun Sight Brightness (analog)	REVI 16 B Gun Sight						
Head Tracker : Forward/Backward							TRACKIR_Z
Head Tracker : Pitch							TRACKIR_PITCH
Head Tracker : Right/Left							TRACKIR_X
Head Tracker : Roll							TRACKIR_ROLL
Head Tracker : Up/Down							TRACKIR_Y
Head Tracker : Yaw							TRACKIR_YAW
Pitch							JOY_Y
Roll							JOY_X
Rudder					JOY_RZ		
TDC Slew Horizontal (mouse)							
TDC Slew Vertical (mouse)							
Throttle			JOY_Z				
Wheel Brake							
Wheel Brake Left					JOY_X		
Wheel Brake Right					JOY_Y		
Zoom View							

To assign axis, click on "Axis Assign". You can also select "Axis Commands" in the upper scrolling menu.

To modify curves and sensitivities of axes, click on the axis you want to modify and then click "Axis Tune".

Modifiers Add Clear Default Axis Assign Axis Tune FF Tune Make HTML Disable hot plug Rescan devices

CANCEL

OK

In the “Special” menu in Options, select the FW190 A-8 menu. Make sure to have Takeoff Assist set to “0” (turned off). By default it is set to 100 (ON). This will cause you to crash and burn inexplicably during takeoff. Also uncheck the Auto-Rudder box.

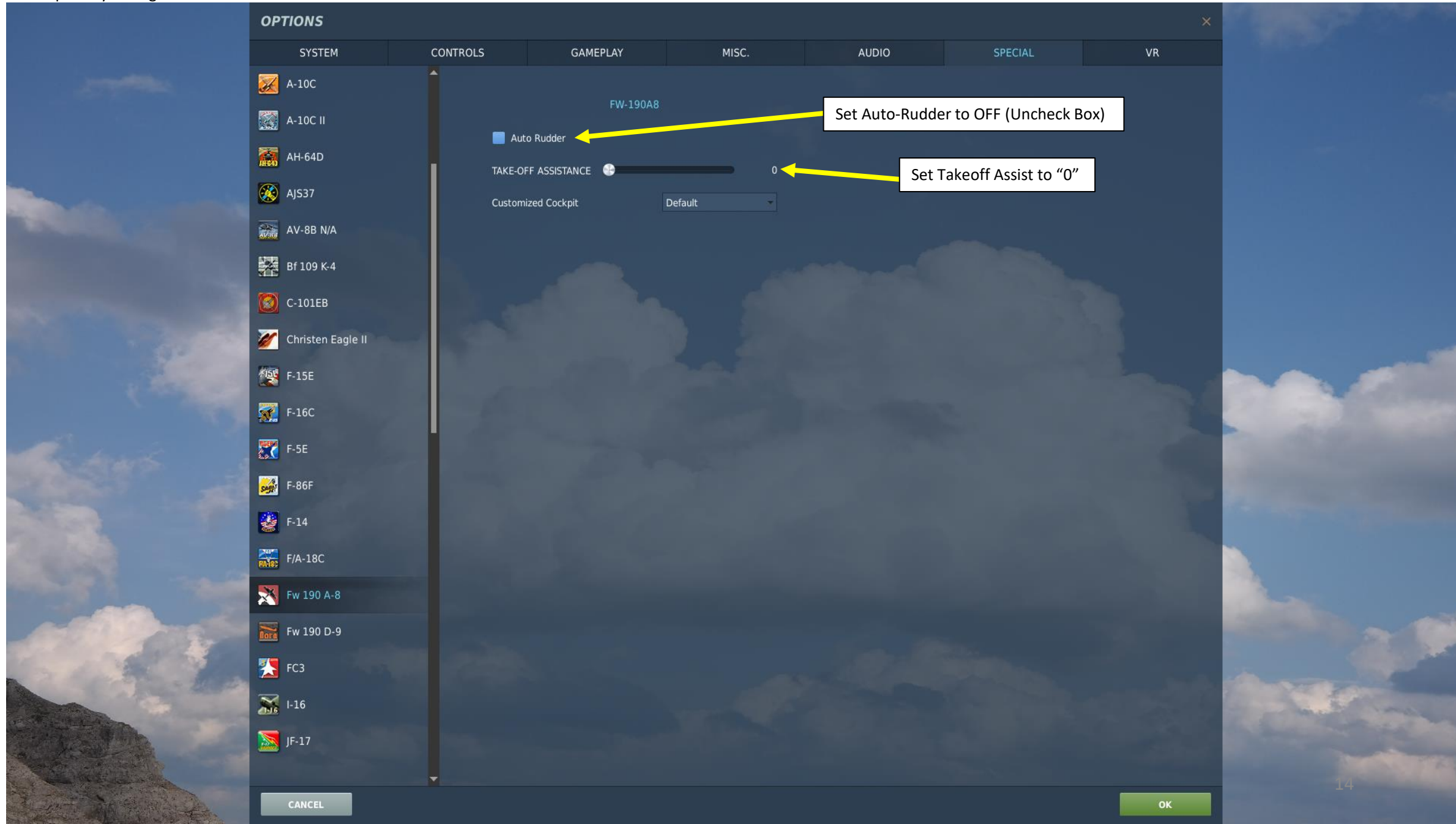



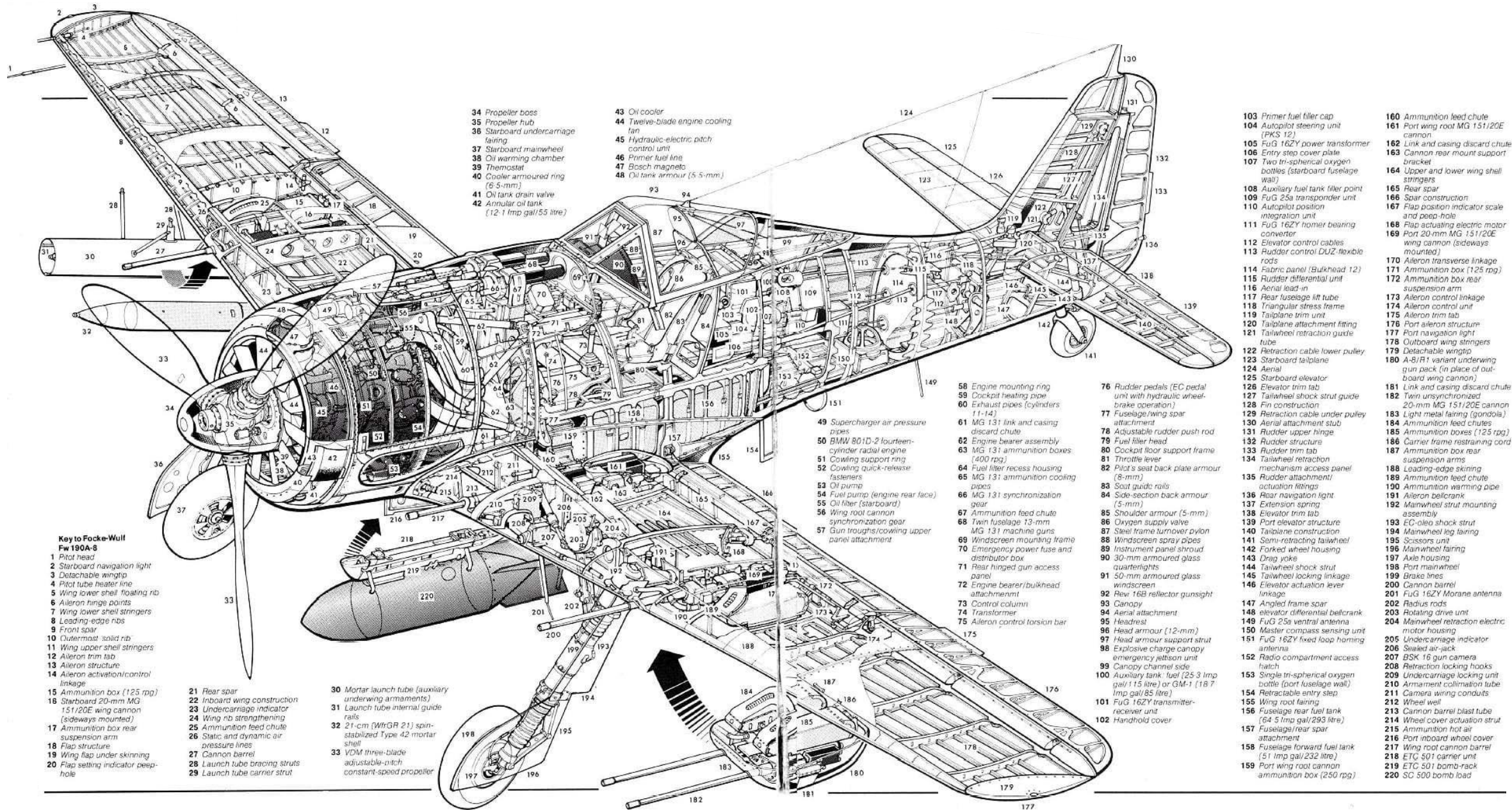

**Key to Focke-Wulf
Fw 190A-8**

- 1 Pitot head
- 2 Starboard navigation light
- 3 Detachable wingtip
- 4 Pitot tube heater line
- 5 Wing lower shell floating rib
- 6 Aileron hinge points
- 7 Wing lower shell stringers
- 8 Leading-edge ribs
- 9 Front spar
- 10 Outermost solid rib
- 11 Wing upper shell stringers
- 12 Aileron trim tab
- 13 Aileron structure
- 14 Aileron activation/control linkage
- 15 Ammunition box (125 rpg)
- 16 Starboard 20-mm MG 151/20E wing cannon (sideways mounted)
- 17 Ammunition box rear suspension arm
- 18 Flap structure
- 19 Wing flap under skinning
- 20 Flap setting indicator peep-hole
- 21 Rear spar
- 22 Inboard wing construction
- 23 Undercarriage indicator
- 24 Wing rib strengthening (sideways mounted)
- 25 Ammunition feed chute
- 26 Static and dynamic air pressure lines
- 27 Cannon barrel
- 28 Launch tube bracing struts
- 29 Launch tube carrier strut

- 30 Mortar launch tube (auxiliary underwing armaments)
- 31 Launch tube internal guide rails
- 32 21-cm (WfGR 21) spin-stabilized Type 42 mortar shell
- 33 VDM three-blade adjustable-pitch constant-speed propeller

- 34 Propeller boss
- 35 Propeller hub
- 36 Starboard undercarriage fairing
- 37 Starboard mainwheel
- 38 Oil warming chamber
- 39 Thermostat
- 40 Cooler armoured ring (6.5-mm)
- 41 Oil tank drain valve
- 42 Annular oil tank (12-1 Imp gal/55 litre)

- 43 Oil cooler
- 44 Twelve-blade engine cooling fan
- 45 Hydraulic-electric pitch control unit
- 46 Primer fuel line
- 47 Bosch magneto
- 48 Oil tank armour (5.5-mm)

- 49 Supercharger air pressure pipes
- 50 BMW 801D-2 fourteen-cylinder radial engine
- 51 Cowling support ring
- 52 Cowling quick-release fasteners
- 53 Oil pump
- 54 Fuel pump (engine rear face)
- 55 Oil filter (starboard)
- 56 Wing root cannon synchronization gear
- 57 Gun troughs/cowling upper panel attachment

- 58 Engine mounting ring
- 59 Cockpit heating pipe
- 60 Exhaust pipes (cylinders 11-14)
- 61 MG 131 link and casing discard chute
- 62 Engine bearer assembly
- 63 MG 131 ammunition boxes (1400 rpg)
- 64 Fuel filter recess housing
- 65 MG 131 ammunition cooling pipes
- 66 MG 131 synchronization gear
- 67 Ammunition feed chute
- 68 Twin fuselage 13-mm MG 131 machine guns
- 69 Windscreen mounting frame
- 70 Emergency power fuse and distributor box
- 71 Rear hinged gun access panel
- 72 Engine bearer/bulkhead attachment
- 73 Control column
- 74 Transformer
- 75 Aileron control torsion bar

- 76 Rudder pedals (EC pedal unit with hydraulic wheel-brake operation)
- 77 Fuselage/wing spar attachment
- 78 Adjustable rudder push rod
- 79 Fuel filler head
- 80 Cockpit floor support frame
- 81 Throttle lever
- 82 Pilot's seat back plate armour (6-mm)
- 83 Seat guide rails
- 84 Side-section back armour (5-mm)
- 85 Shoulder armour (5-mm)
- 86 Oxygen supply valve
- 87 Steel frame turnover pylon
- 88 Windscreen spray pipes
- 89 Instrument panel shroud
- 90 30-mm armoured glass quarterlights
- 91 50-mm armoured glass windscreen
- 92 Rev 16B reflector gunsight
- 93 Canopy
- 94 Aerial attachment
- 95 Headrest
- 96 Head armour (12-mm)
- 97 Head armour support strut
- 98 Explosive charge canopy emergency jettison unit
- 99 Canopy channel side
- 100 Auxiliary tank: fuel (25.3 Imp gal/115 litre) or GM-1 (18.7 Imp gal/85 litre)
- 101 FuG 16Z transmitter-receiver unit
- 102 Handhold cover

- 103 Primer fuel filler cap
- 104 Autopilot steering cap (PKS 12)
- 105 FuG 16Z power transformer
- 106 Entry step cover plate
- 107 Two tri-spherical oxygen bottles (starboard fuselage wall)
- 108 Auxiliary fuel tank filter point
- 109 FuG 25a transponder unit
- 110 Autopilot position integration unit
- 111 FuG 16Z homer bearing converter
- 112 Elevator control cables
- 113 Rudder control DUZ flexible rods
- 114 Fabric panel (Bulkhead 12)
- 115 Rudder differential unit
- 116 Aerial lead-in
- 117 Rear fuselage lift tube
- 118 Triangular stress frame
- 119 Tailplane trim unit
- 120 Tailplane attachment fitting
- 121 Tailwheel retraction guide tube
- 122 Retraction cable lower pulley
- 123 Starboard tailplane
- 124 Aerial
- 125 Starboard elevator
- 126 Elevator trim tab
- 127 Tailwheel shock strut guide
- 128 Fin construction
- 129 Retraction cable under pulley attachment
- 130 Aerial attachment stub
- 131 Rudder upper hinge
- 132 Rudder structure
- 133 Rudder trim tab
- 134 Tailwheel retraction mechanism access panel
- 135 Rudder attachment actuation fittings
- 136 Rear navigation light
- 137 Extension spring
- 138 Elevator trim tab
- 139 Port elevator structure
- 140 Tailplane construction
- 141 Semi-retracting tailwheel
- 142 Forked wheel housing
- 143 Drag yoke
- 144 Tailwheel shock strut
- 145 Tailwheel locking linkage
- 146 Elevator actuation lever linkage
- 147 Angled frame spar
- 148 elevator differential bellcrank
- 149 FuG 25a ventral antenna
- 150 Master compass sensing unit
- 151 FuG 16Z fixed loop homing antenna
- 152 Explosive charge canopy emergency jettison unit
- 153 Radio compartment access hatch
- 154 Single tri-spherical oxygen bottle (port fuselage wall)
- 155 Retractable entry step
- 156 Wing root fairing
- 157 Fuselage rear fuel tank (64.5 Imp gal/293 litre)
- 158 Fuselage/rear spar attachment
- 159 Fuselage forward fuel tank (51 Imp gal/232 litre)
- 160 Port wing root cannon
- 161 Ammunition feed chute
- 162 Link and casing discard chute
- 163 Cannon rear mount support bracket
- 164 Upper and lower wing shell stringers
- 165 Rear spar
- 166 Spar construction
- 167 Flap position indicator scale and peep-hole
- 168 Flap actuating electric motor
- 169 Port 20 mm MG 151/20E wing cannon (sideways mounted)
- 170 Aileron transverse linkage
- 171 Ammunition box (125 rpg)
- 172 Ammunition box rear suspension arm
- 173 Aileron control linkage
- 174 Aileron control unit
- 175 Aileron trim tab
- 176 Port aileron structure
- 177 Port navigation light
- 178 Outboard wing stringers
- 179 Detachable wingtip
- 180 A-B/R1 variant underwing gun pack (in place of outboard wing cannon)
- 181 Link and casing discard chute
- 182 Twin unsynchronized 20-mm MG 151/20E cannon
- 183 Light metal fairing (gondola)
- 184 Ammunition feed chutes
- 185 Ammunition boxes (125 rpg)
- 186 Carrier frame restraining cord
- 187 Ammunition box rear suspension arms
- 188 Leading-edge skimming
- 189 Ammunition feed chute
- 190 Ammunition warming pipe
- 191 Aileron bellcrank
- 192 Mainwheel strut mounting assembly
- 193 EC-oleo shock strut
- 194 Mainwheel leg fairing
- 195 Scissors unit
- 196 Mainwheel fairing
- 197 Axle housing
- 198 Port mainwheel
- 199 Brake lines
- 200 Cannon barrel
- 201 FuG 16Z Morane antenna
- 202 Radium rods
- 203 Rotating drive unit
- 204 Mainwheel retraction electric motor housing
- 205 Undercarriage indicator
- 206 Sealed air-jack
- 207 BSK 16 gun camera
- 208 Retraction locking hooks
- 209 Undercarriage locking unit
- 210 Armament collimation tube
- 211 Camera wiring conduits
- 212 Wheel well
- 213 Cannon barrel blast tube
- 214 Wheel cover actuation strut
- 215 Ammunition hot air
- 216 Port inboard wheel cover
- 217 Wing root cannon barrel
- 218 ETC 501 carrier unit
- 219 ETC 501 bomb-rack
- 220 SC 500 bomb load



Tip: Pilot body can be toggled ON/OFF with "RSHIFT+P"



Achtung!

**Haubenabwurf
durch Sprengladung**

*Abwurthebel nicht berühren. Im Probefall
vorherige Sicherung des Schlagbolzens*





PART 3 - COCKPIT & EQUIPMENT



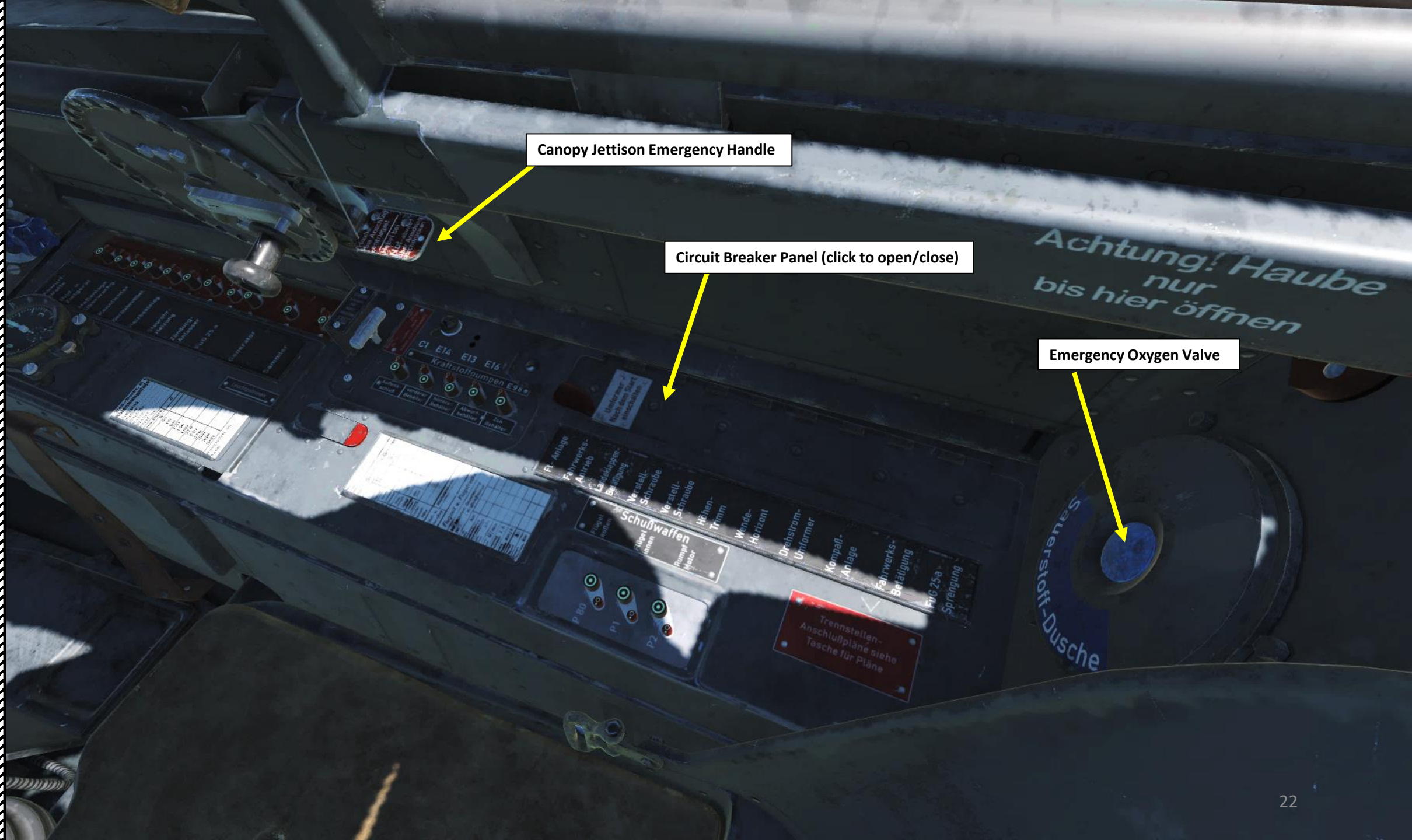

Canopy Jettison Emergency Handle

Circuit Breaker Panel (click to open/close)

Emergency Oxygen Valve

Propeller Pitch Controls
(Verstellschraube) Circuit Breaker

Horizontal Stabilizer Trim (Höhentrimm) Circuit Breaker

Note: Black buttons (circuit breaker) power the system when pressed IN, red buttons unpower the system when pressed IN.

Propeller Pitch Drive (Verstellschraube)
Circuit Breaker

Artificial Horizon (Wendehorizont) Circuit Breaker

Engine Generator (Drehstrom Umformer) Circuit Breaker

Landing Flaps Actuation (Landeklappen
Betätigung) Circuit Breaker

Repeater Compass (Kompaß Anlage) Circuit Breaker

Landing Gear Drive (fahrwerks
Antrieb) Circuit Breaker

Landing Gear Actuation (Fahrwerks
Betätigung) Circuit Breaker

FuG 16 ZY Radio (FT-Anlage)
Circuit Breaker

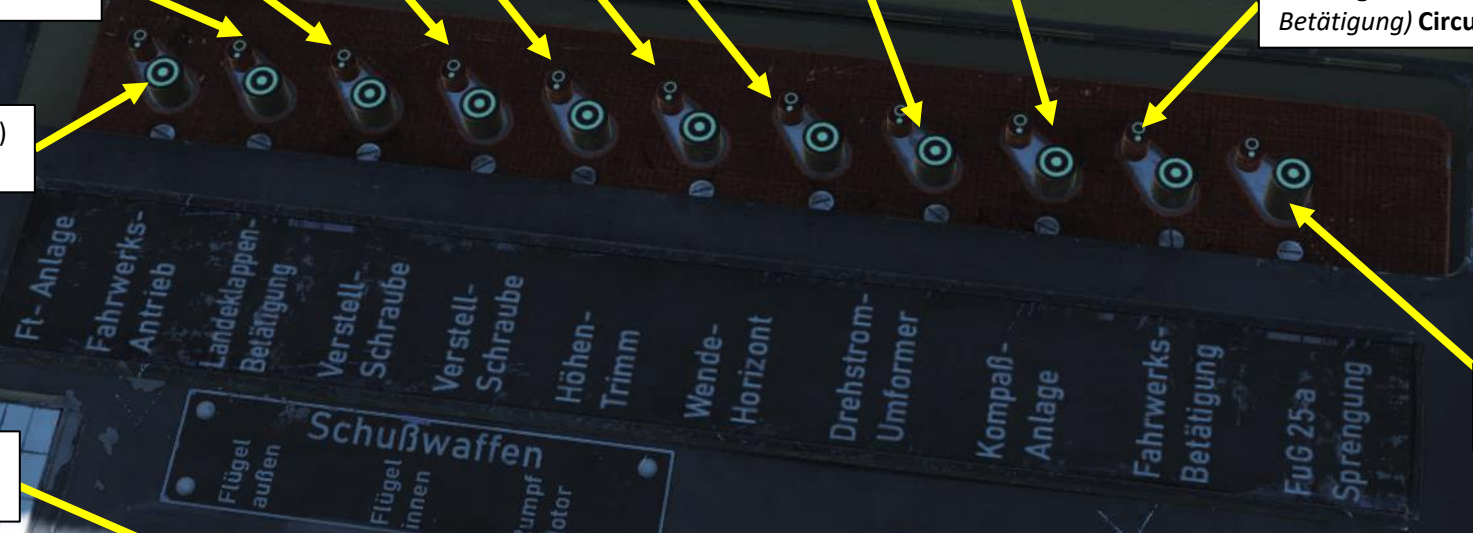

FuG 25a IFF (Identify-Friend-or-Foe) Self-
Destruction (Sprengung) Circuit Breaker

Inner Wing (Innenflügel)
Armament Circuit Breaker



Outer Wing (Außenflügel)
Armament Circuit Breaker



Engine-Mounted (Rumpf Motor)
Armament Circuit Breaker



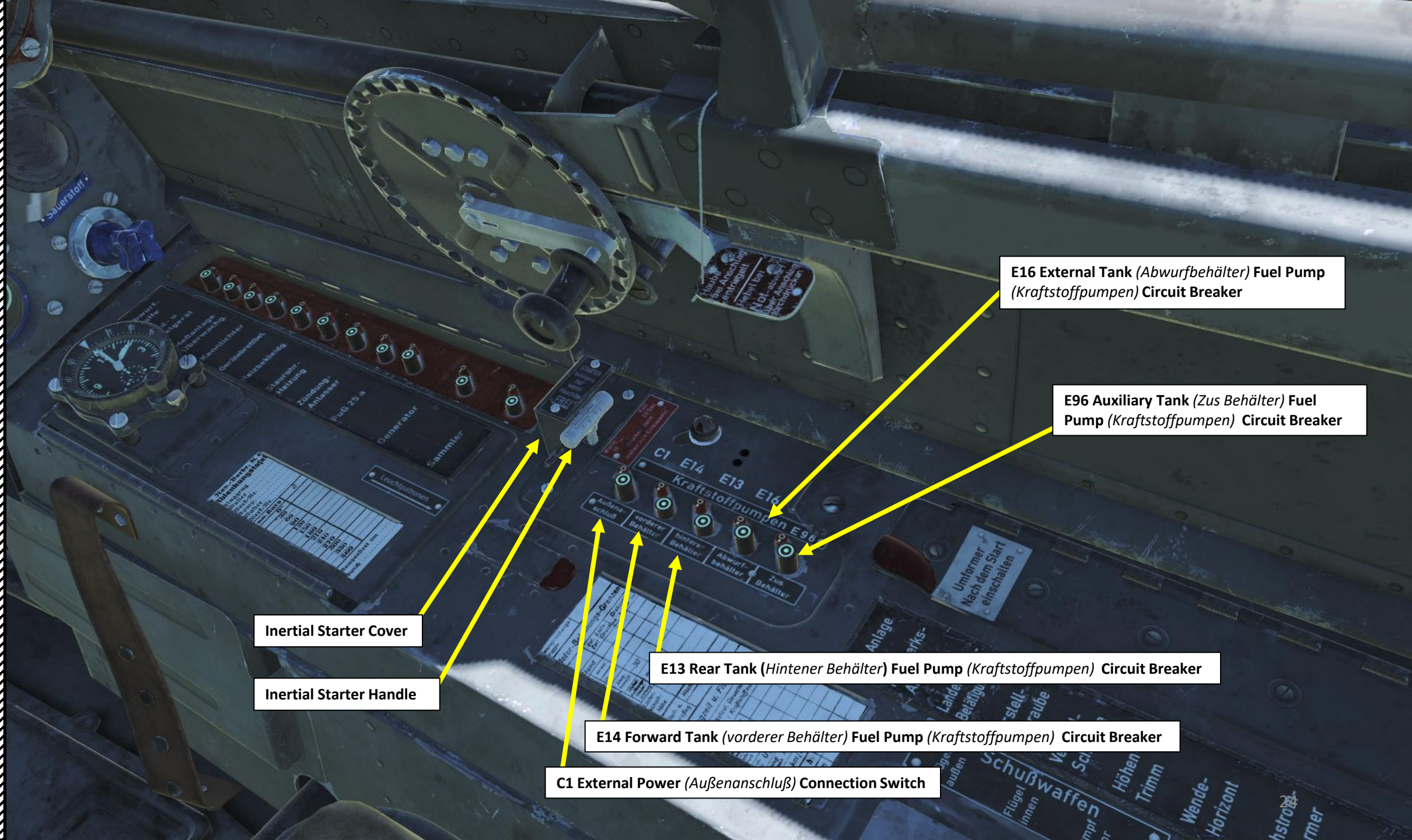

E16 External Tank (*Abwurfbehälter*) Fuel Pump (*Kraftstoffpumpen*) Circuit Breaker

E96 Auxiliary Tank (*Zus Behälter*) Fuel Pump (*Kraftstoffpumpen*) Circuit Breaker

E13 Rear Tank (*Hintener Behälter*) Fuel Pump (*Kraftstoffpumpen*) Circuit Breaker

E14 Forward Tank (*vorderer Behälter*) Fuel Pump (*Kraftstoffpumpen*) Circuit Breaker

C1 External Power (*Außenanschluß*) Connection Switch

Inertial Starter Cover

Inertial Starter Handle

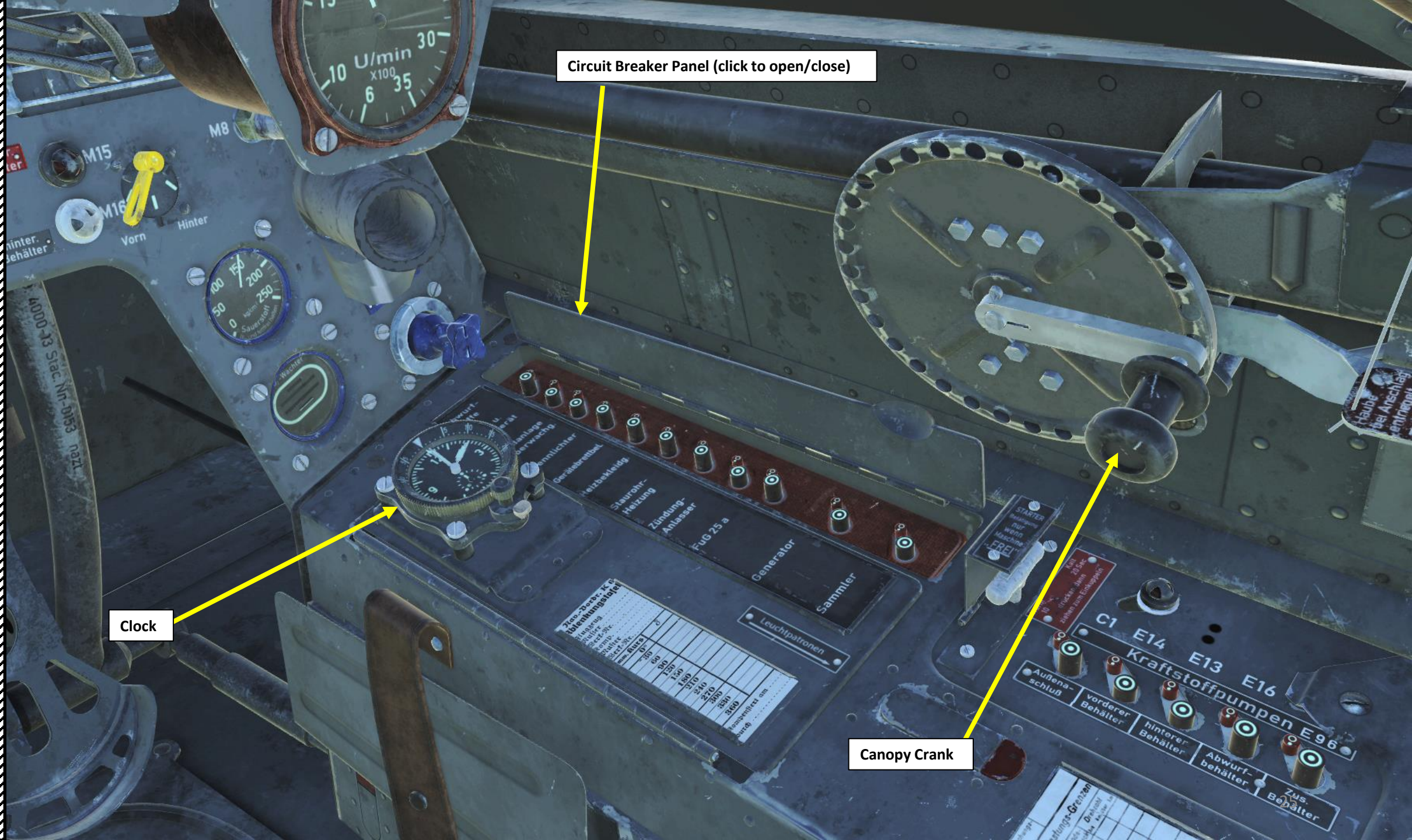

Circuit Breaker Panel (click to open/close)

Clock

Canopy Crank

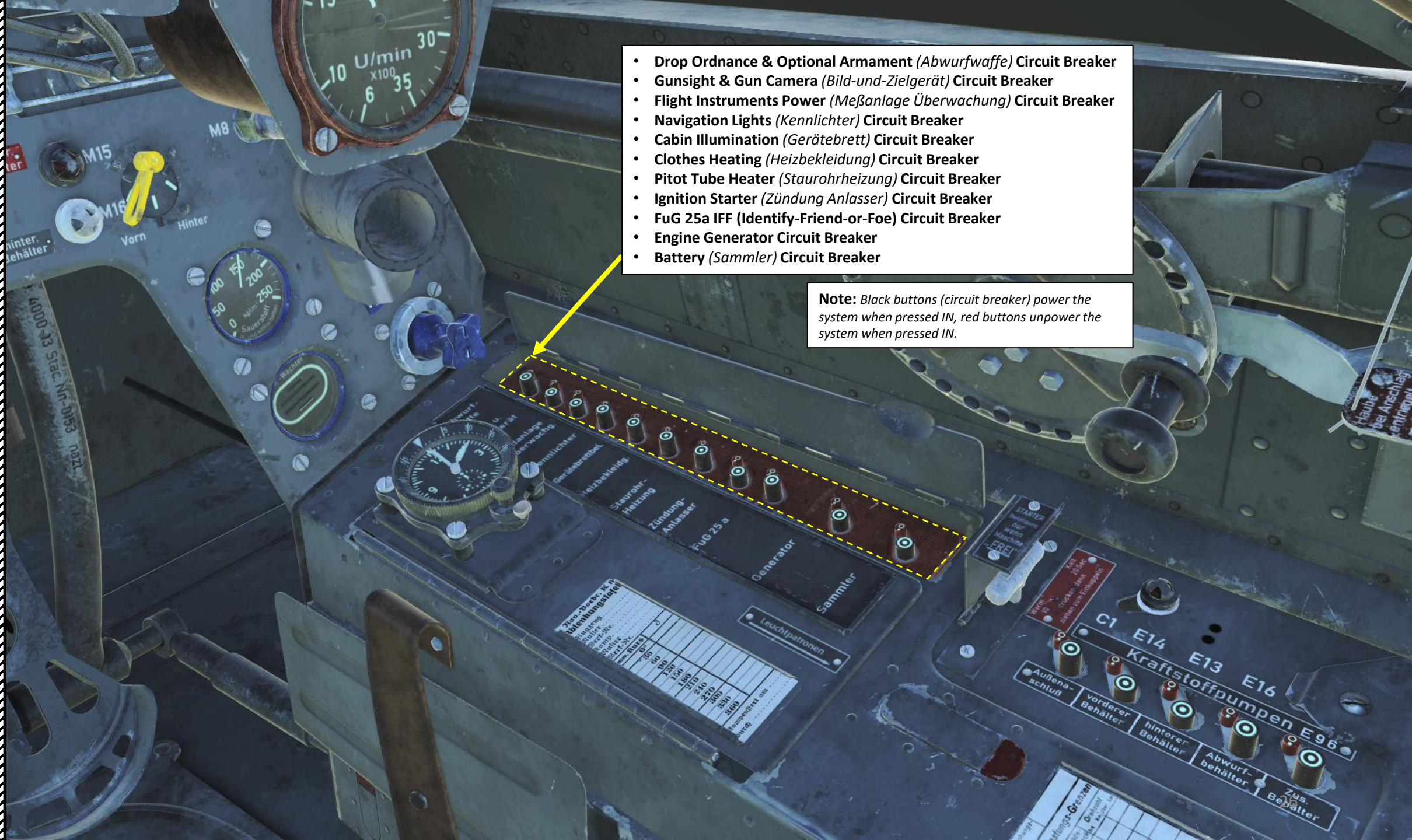

- Drop Ordnance & Optional Armament (*Abwurfwaffe*) Circuit Breaker
- Gunsight & Gun Camera (*Bild-und-Zielgerät*) Circuit Breaker
- Flight Instruments Power (*Meßanlage Überwachung*) Circuit Breaker
- Navigation Lights (*Kennlichter*) Circuit Breaker
- Cabin Illumination (*Gerätebrett*) Circuit Breaker
- Clothes Heating (*Heizbekleidung*) Circuit Breaker
- Pitot Tube Heater (*Staurohrheizung*) Circuit Breaker
- Ignition Starter (*Zündung Anlasser*) Circuit Breaker
- FuG 25a IFF (Identify-Friend-or-Foe) Circuit Breaker
- Engine Generator Circuit Breaker
- Battery (*Sammler*) Circuit Breaker

Note: Black buttons (circuit breaker) power the system when pressed IN, red buttons unpower the system when pressed IN.

700-2003 K 4 Abhängigkeit	
Abhängigkeit	Abhängigkeit
100	100
150	150
200	200
250	250
300	300
350	350
400	400
450	450
500	500
550	550
600	600
650	650
700	700
750	750
800	800
850	850
900	900
950	950
1000	1000

Abhängigkeit	
Abhängigkeit	Abhängigkeit
100	100
150	150
200	200
250	250
300	300
350	350
400	400
450	450
500	500
550	550
600	600
650	650
700	700
750	750
800	800
850	850
900	900
950	950
1000	1000



Fuel Gauge (x100 Liters)

- Vorn/Front Tank Capacity: 232 L (172 kg)
- Hinten/Rear Tank Capacity: 292 L (216 kg)
- Total Capacity: 524 L (388 kg)

Fuel Gauge Indication Selector

- Left: Vorn = Front
- Middle: No Tank Selected
- Right: Hinten = Rear

Note: If an external drop tank is installed, selector should be set to "HINTEN" (Rear) since drop tanks feed into the rear tank.



vorder Behälter

hinter Behälter

Vorn Hinten

Front (vorder Behälter) Tank FUEL LOW warning light

- Illuminates when below 80 Liters

Rear (Hinten Behälter) Tank FUEL LOW warning light

- Illuminates when below 10 Liters

Oxygen Pressure Indicator (kg/cm²)

Oxygen Flow Indicator

Oxygen Flow Valve Control



Restwarnung!
15 Minuten



Variometer (Climb/Sink Rate in m/s)

Repeater Compass

Supercharger Pressure Gauge (ATA)
Similar to Boost or Manifold Pressure

Engine RPM/Umin x100

Propeller Pitch Indicator
 • 6:00 position: 100 % (Fine) Pitch
 • 12:30 position: 0 % (Coarse) Pitch

Indicator	Pitch	Indicator	Pitch	Indicator	Pitch
6:00	100%	6:19	95%	6:39	90%
6:58	85%	7:18	80%	7:37	75%
7:57	70%	8:16	65%	8:36	60%
8:55	55%	9:15	50%	9:34	45%
9:54	40%	10:13	35%	10:33	30%
10:52	25%	11:12	20%	11:31	15%
11:51	10%	12:10	5%	12:30	0%



Artificial Horizon and
Turn & Bank Indicator

AFN-2 Homing Indicator



Gunsight



Gunsight Smoked Screen Lever

Gunsight Brightness Adjustment Control



Gunsight Smoked Screen Lever

MG 151 Cannon Breechblock Status Signal Lamp

- Illuminated: Open
- Extinguished: Closed

Lamp flickering when firing the weapon means the breechblock mechanism operates properly. If lamp remains extinguished or illuminated when trigger is pressed, a weapon malfunction has occurred.

Master Arm Safety I Switch (Machineguns and Inner Wing Cannons)

- UP: ON / DOWN : OFF

MG 151 Cannon Ammunition Counter

MG 131 Machinegun Breechblock Status Signal Lamp

- Illuminated: Open
- Extinguished: Closed

Lamp flickering when firing the weapon means the breechblock mechanism operates properly. If lamp remains extinguished or illuminated when trigger is pressed, a weapon malfunction has occurred.

MG 151 Cannon Ammunition Counter Setting knob

Master Arm Safety II Switch (Outer Wing Cannons)

- UP: ON / DOWN : OFF

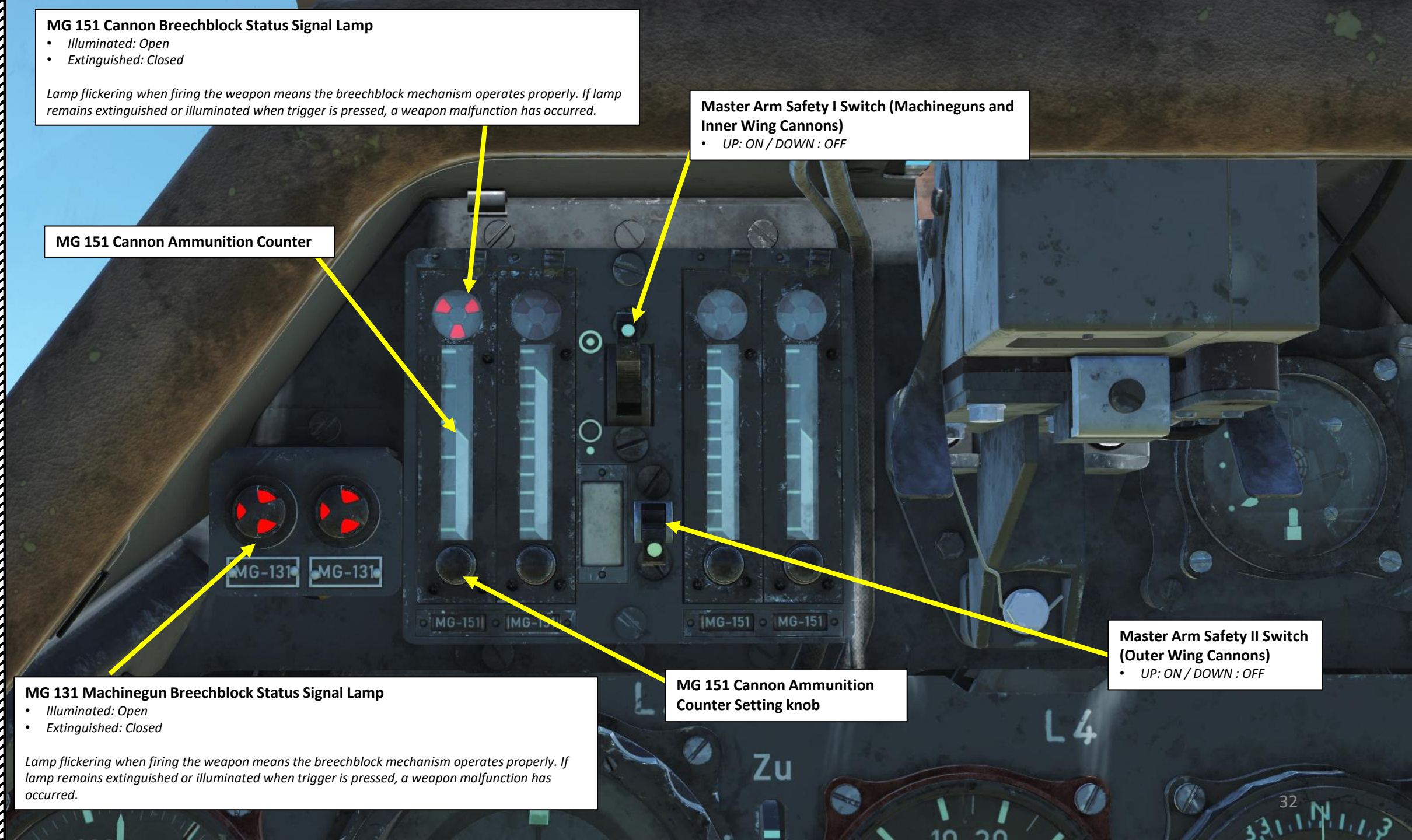

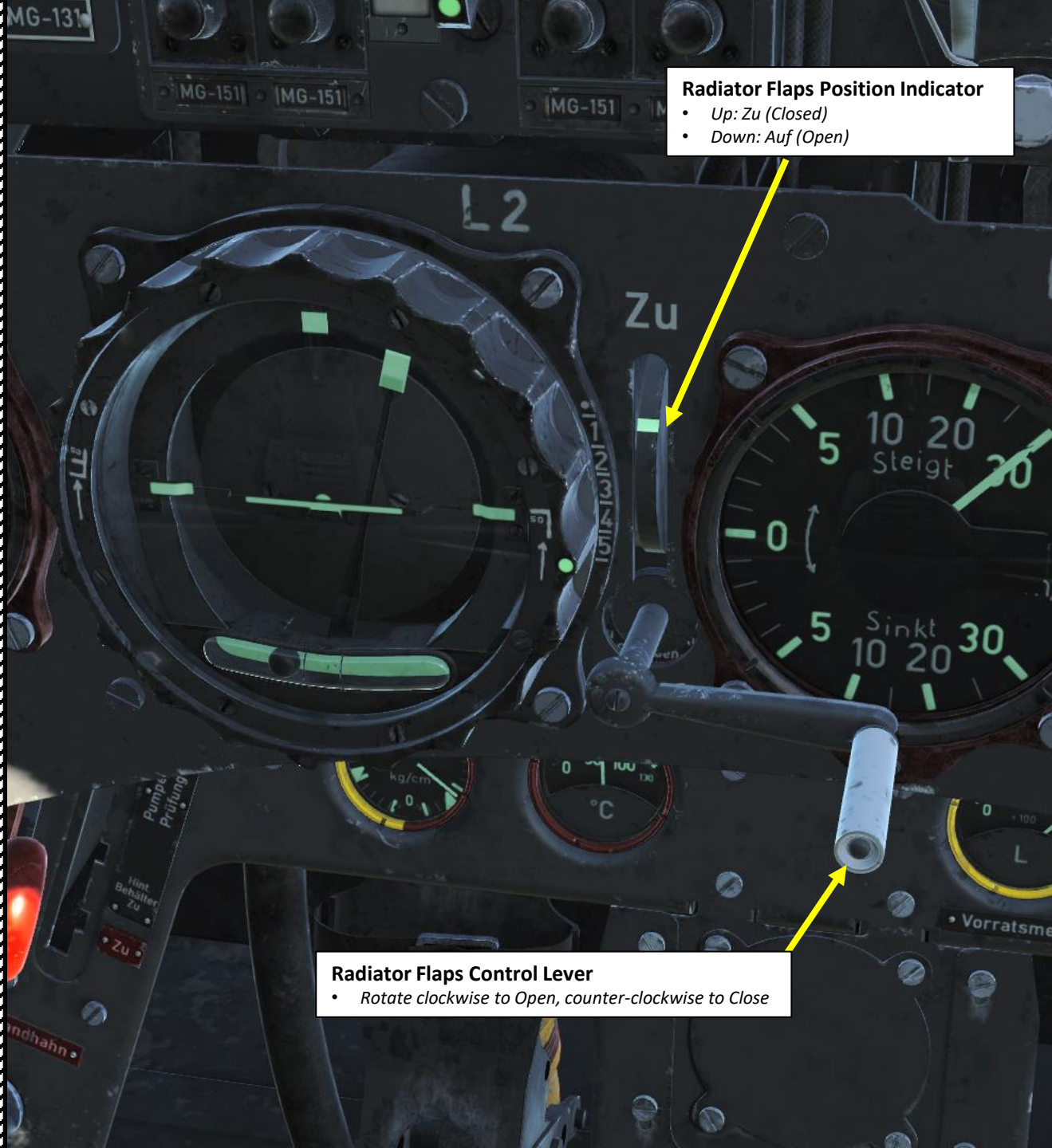

Radiator Flaps Position Indicator

- Up: Zu (Closed)
- Down: Auf (Open)

Radiator Flaps Control Lever

- Rotate clockwise to Open, counter-clockwise to Close



Radiator Flaps

Pitot Tube Heater Indicator
• Illuminated = Pitot Heater On

Altimeter (km)

Barometric Pressure (QFE) Setting Knob

Barometric Pressure Setting (hPa)

Airspeed Indicator (km/h)
Not to Exceed diving speeds are handwritten on the airspeed gauge

Airspeed @ Altitude

- 500 km/h @ 9 km
- 600 km/h @ 7 km
- 700 km/h @ 5 km
- 800 km/h @ 3 km
- 850 km/h @ 2 km

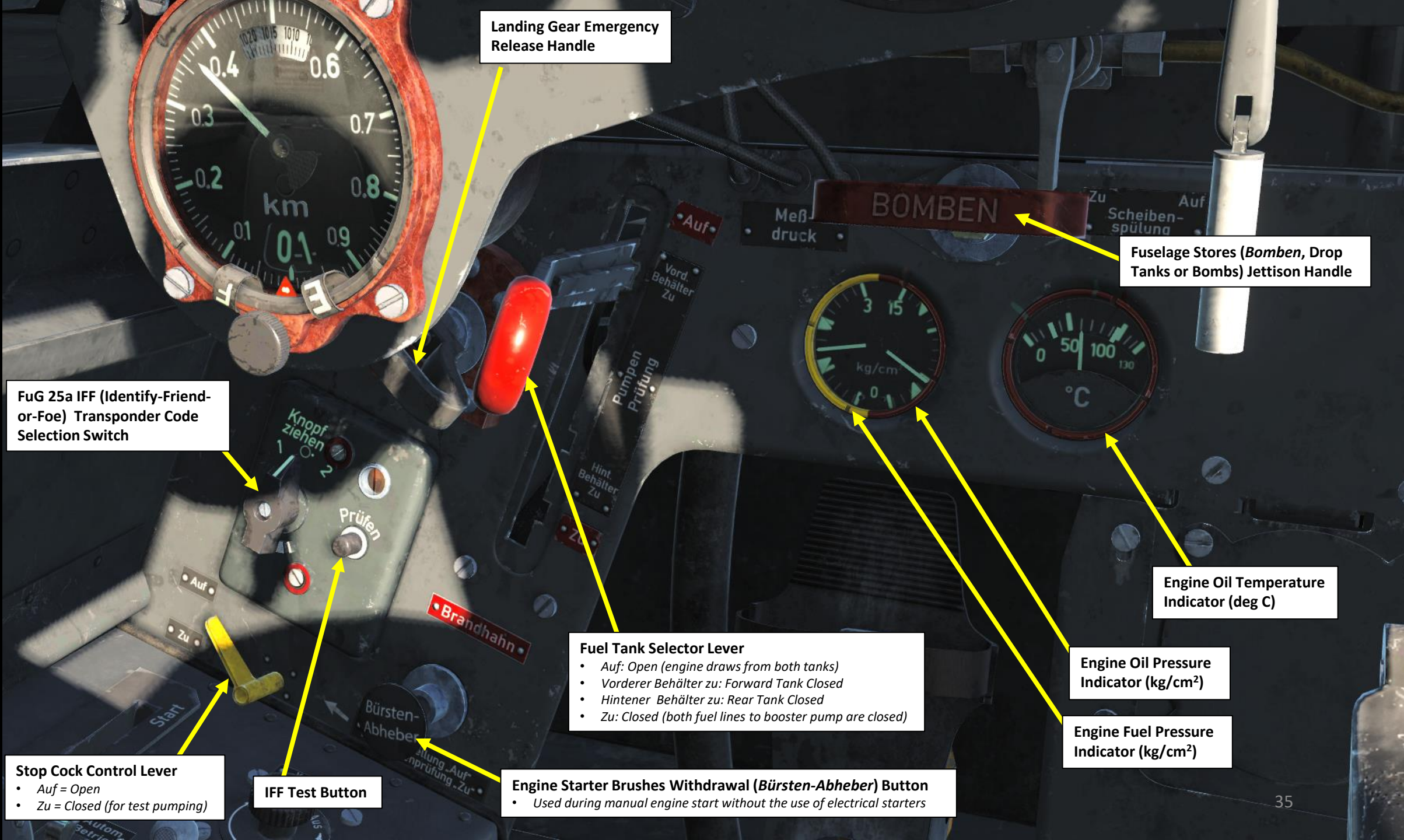

Landing Gear Emergency Release Handle

Fuselage Stores (*Bomben*, Drop Tanks or Bombs) Jettison Handle

FuG 25a IFF (Identify-Friend-or-Foe) Transponder Code Selection Switch

Engine Oil Temperature Indicator (deg C)

Fuel Tank Selector Lever

- *Auf*: Open (engine draws from both tanks)
- *Vorderer Behälter zu*: Forward Tank Closed
- *Hintener Behälter zu*: Rear Tank Closed
- *Zu*: Closed (both fuel lines to booster pump are closed)

Engine Oil Pressure Indicator (kg/cm²)

Stop Cock Control Lever

- *Auf* = Open
- *Zu* = Closed (for test pumping)

IFF Test Button

Engine Starter Brushes Withdrawal (*Bürsten-Abheber*) Button

- Used during manual engine start without the use of electrical starters

Engine Fuel Pressure Indicator (kg/cm²)

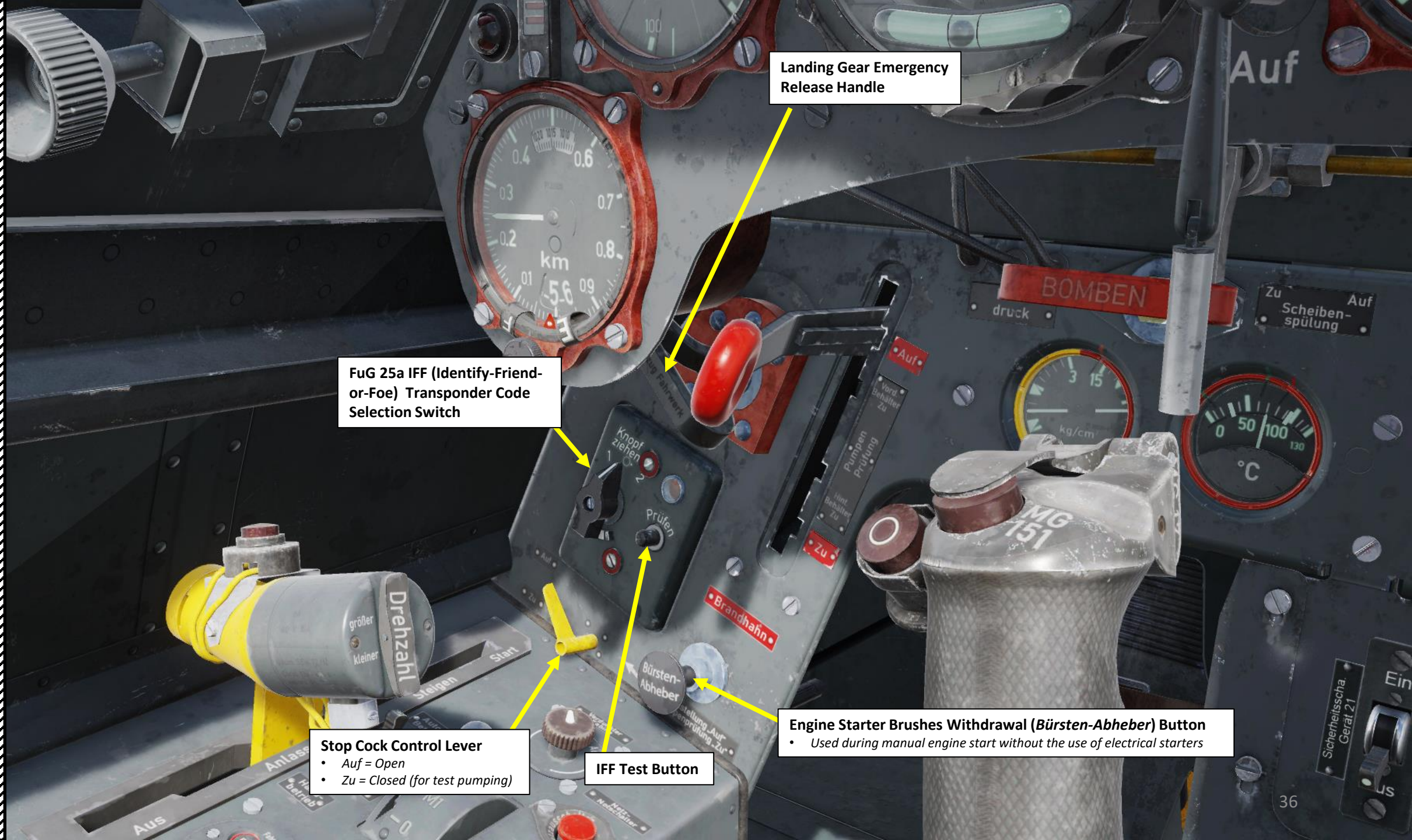

Landing Gear Emergency Release Handle

FuG 25a IFF (Identify-Friend-or-Foe) Transponder Code Selection Switch

Stop Cock Control Lever
• Auf = Open
• Zu = Closed (for test pumping)

IFF Test Button

Engine Starter Brushes Withdrawal (Bürsten-Abheber) Button
• Used during manual engine start without the use of electrical starters





Rudder Pedal

Flight Control Stick

Rudder Pedal

Rocket Arming Switch
(SICHERHEITSSCHA. GERÄT 21)

- Ein: Armed
- Aus: Disarmed

Rocket Jettison Switch
(ABSPRENGSCHA. GERÄT 21)

- Ein: Armed
- Aus: Disarmed

Bomb Loaded Lights

Bomb Fuze Armed Light

Bomb Release Mode Selector Switch

- Left side: Dive Bombing (Sturz)
 - MV: Mit Verzögerung (with delay)
 - OV: Ohne Verzögerung (without delay)
- Right side: Level Bombing (Wagerecht)
 - MV: Mit Verzögerung (with delay)
 - OV: Ohne Verzögerung (without delay)
- Middle: Aus (Disarmed)

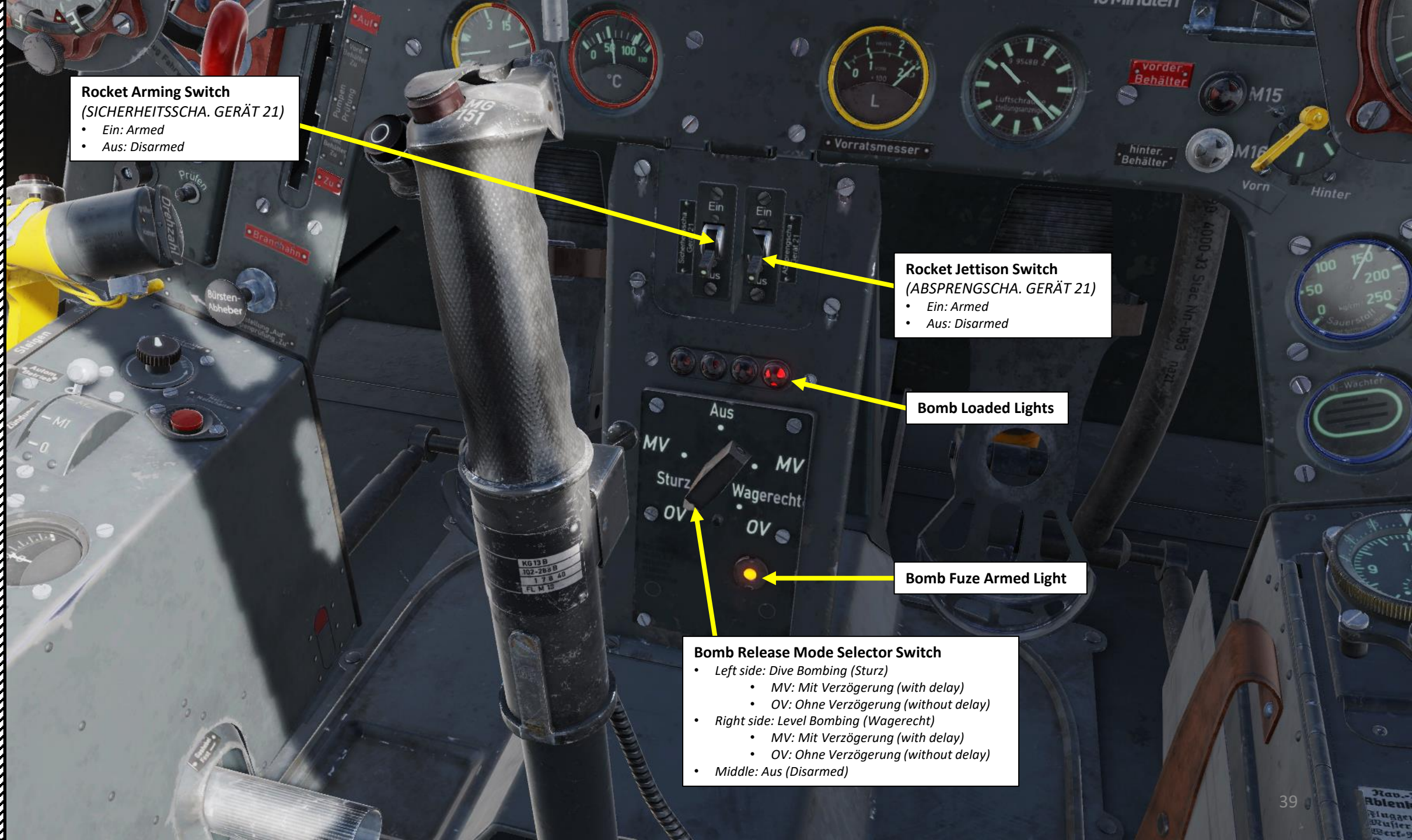

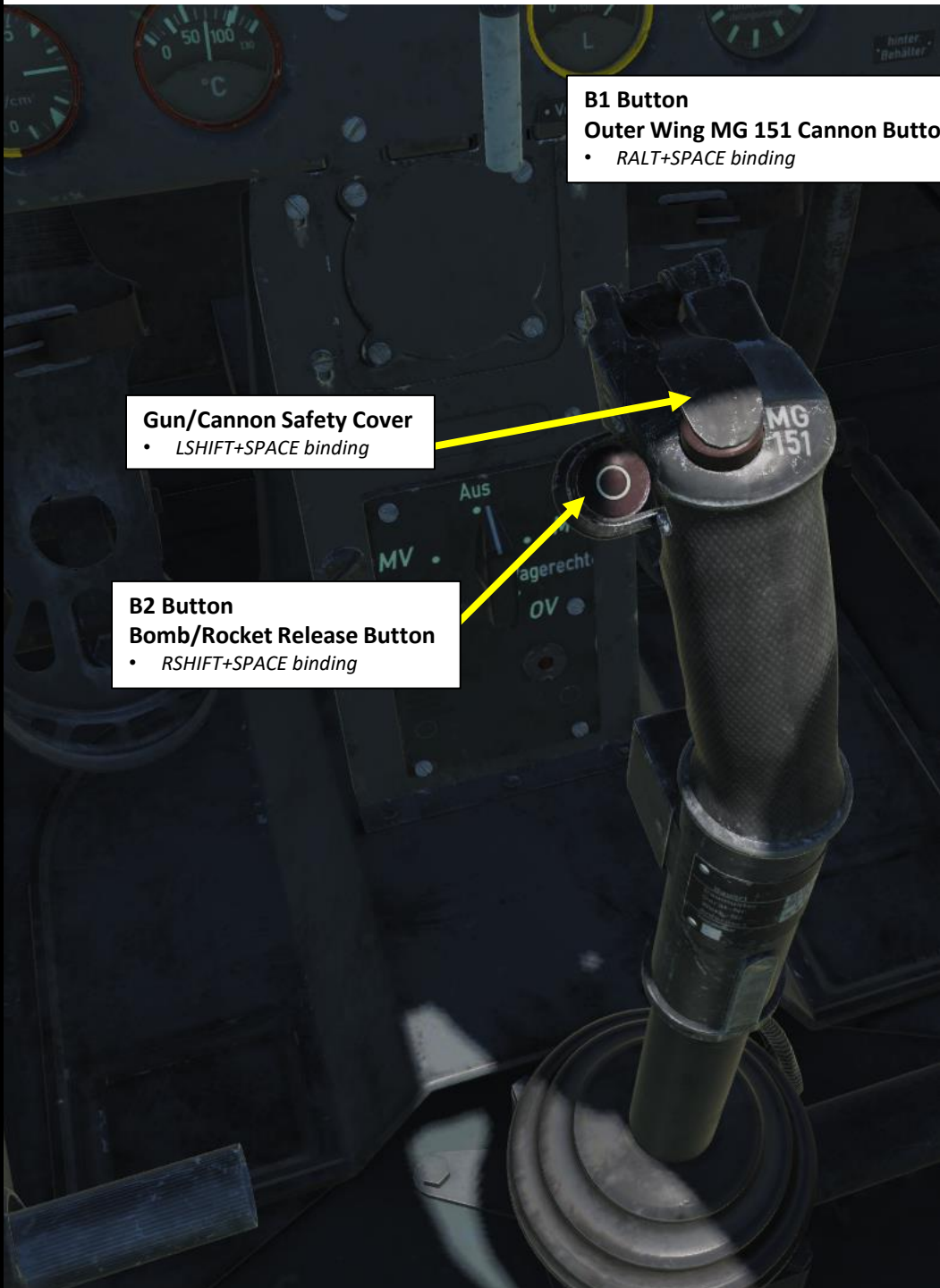

B1 Button
Outer Wing MG 151 Cannon Button
• *RALT+SPACE* binding

Gun/Cannon Safety Cover
• *LSHIFT+SPACE* binding

B2 Button
Bomb/Rocket Release Button
• *RSHIFT+SPACE* binding



A Button
Inner Wing MG 151 Cannon & MG 131 Machinegun Button
• *Note: If the Cannon Safety Cover is ON, the MG 151/131 Trigger will only fire machineguns when pressed.*





PART 3 – COCKPIT & EQUIPMENT

FW190-A8
ANTON



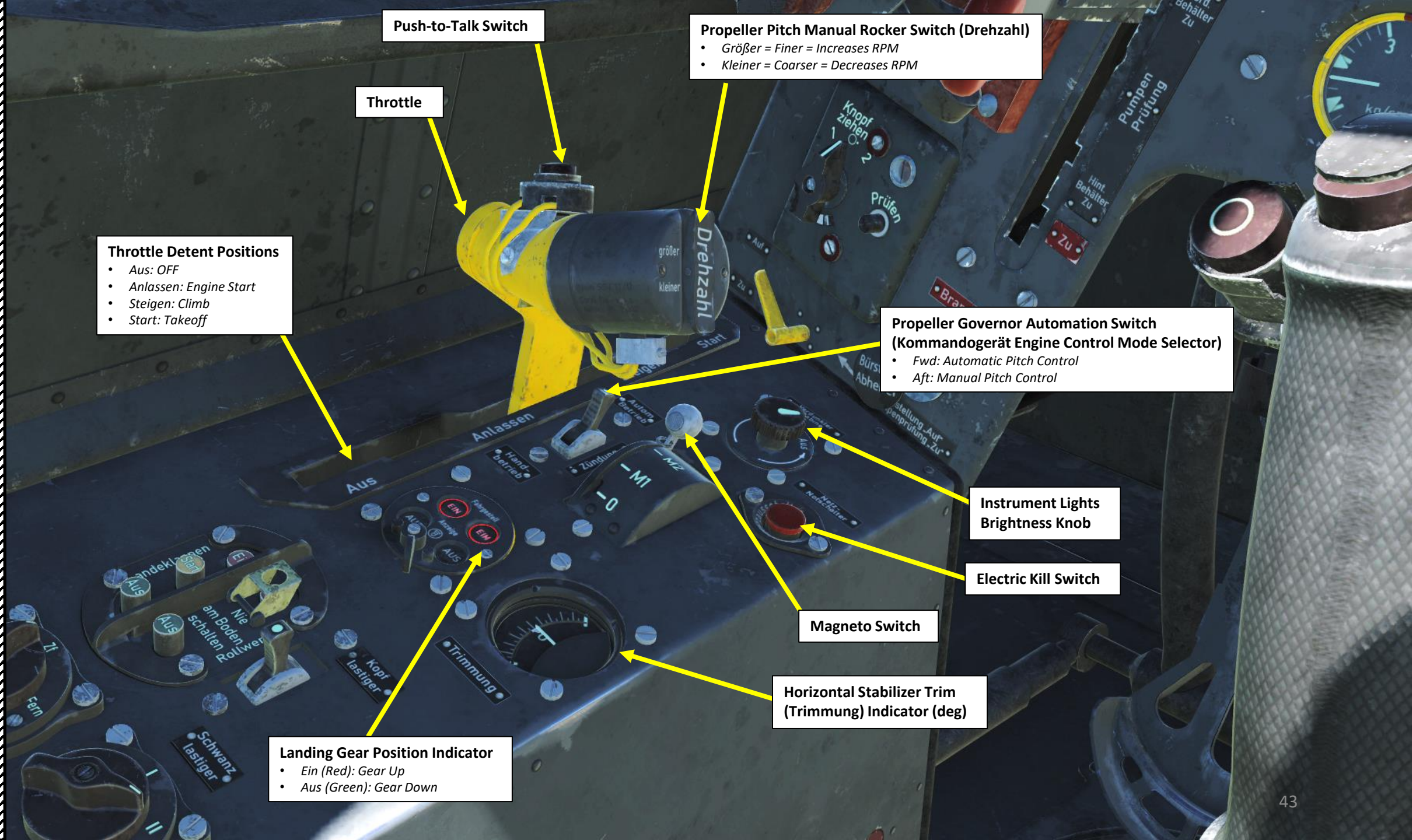

Push-to-Talk Switch

Throttle

Propeller Pitch Manual Rocker Switch (Drehzahl)

- Größer = Finer = Increases RPM
- Kleiner = Coarser = Decreases RPM

Throttle Detent Positions

- Aus: OFF
- Anlassen: Engine Start
- Steigen: Climb
- Start: Takeoff

Propeller Governor Automation Switch (Kommandogerät Engine Control Mode Selector)

- Fwd: Automatic Pitch Control
- Aft: Manual Pitch Control

Instrument Lights Brightness Knob

Electric Kill Switch

Magneto Switch

Horizontal Stabilizer Trim (Trimmung) Indicator (deg)

Landing Gear Position Indicator

- Ein (Red): Gear Up
- Aus (Green): Gear Down



Throttle Lock
• Down: Locked
• Up: Unlocked

Flaps (Landeklappen) Control Buttons

- Ein: Flaps retracted
- Start: Takeoff Position (10 deg)
- Aus: Flaps Deployed (60 deg)

Landing Gear Control Buttons

- Ein: Gear Up
- Aus: Gear Down

Landing Gear Button Safety Cover

Horizontal Stabilizer Trim Control Switch

- Kopflastiger = Nose Down
- Schwanzlastiger = Nose Up

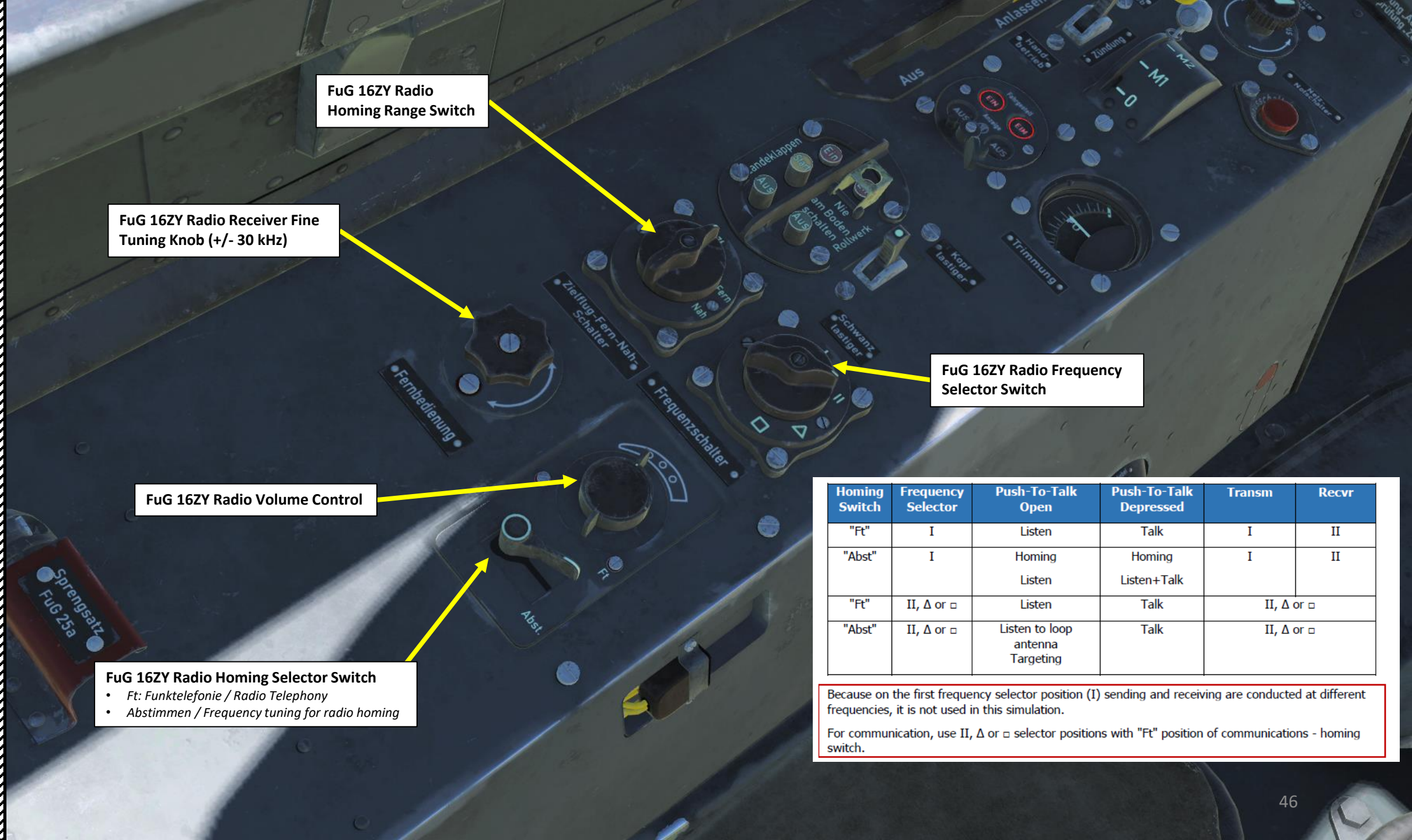

FuG 16ZY Radio
Homing Range Switch

FuG 16ZY Radio Receiver Fine
Tuning Knob (+/- 30 kHz)

FuG 16ZY Radio Frequency
Selector Switch

FuG 16ZY Radio Volume Control

FuG 16ZY Radio Homing Selector Switch

- Ft: Funktelefonie / Radio Telephony
- Abstimmen / Frequency tuning for radio homing

Homing Switch	Frequency Selector	Push-To-Talk Open	Push-To-Talk Depressed	Transm	Recvr
"Ft"	I	Listen	Talk	I	II
"Abst"	I	Homing Listen	Homing Listen+Talk	I	II
"Ft"	II, Δ or □	Listen	Talk	II, Δ or □	
"Abst"	II, Δ or □	Listen to loop antenna Targeting	Talk	II, Δ or □	

Because on the first frequency selector position (I) sending and receiving are conducted at different frequencies, it is not used in this simulation.

For communication, use II, Δ or □ selector positions with "Ft" position of communications - homing switch.

Fuel Primer Pump Handle

Headset Cord Attachment Point

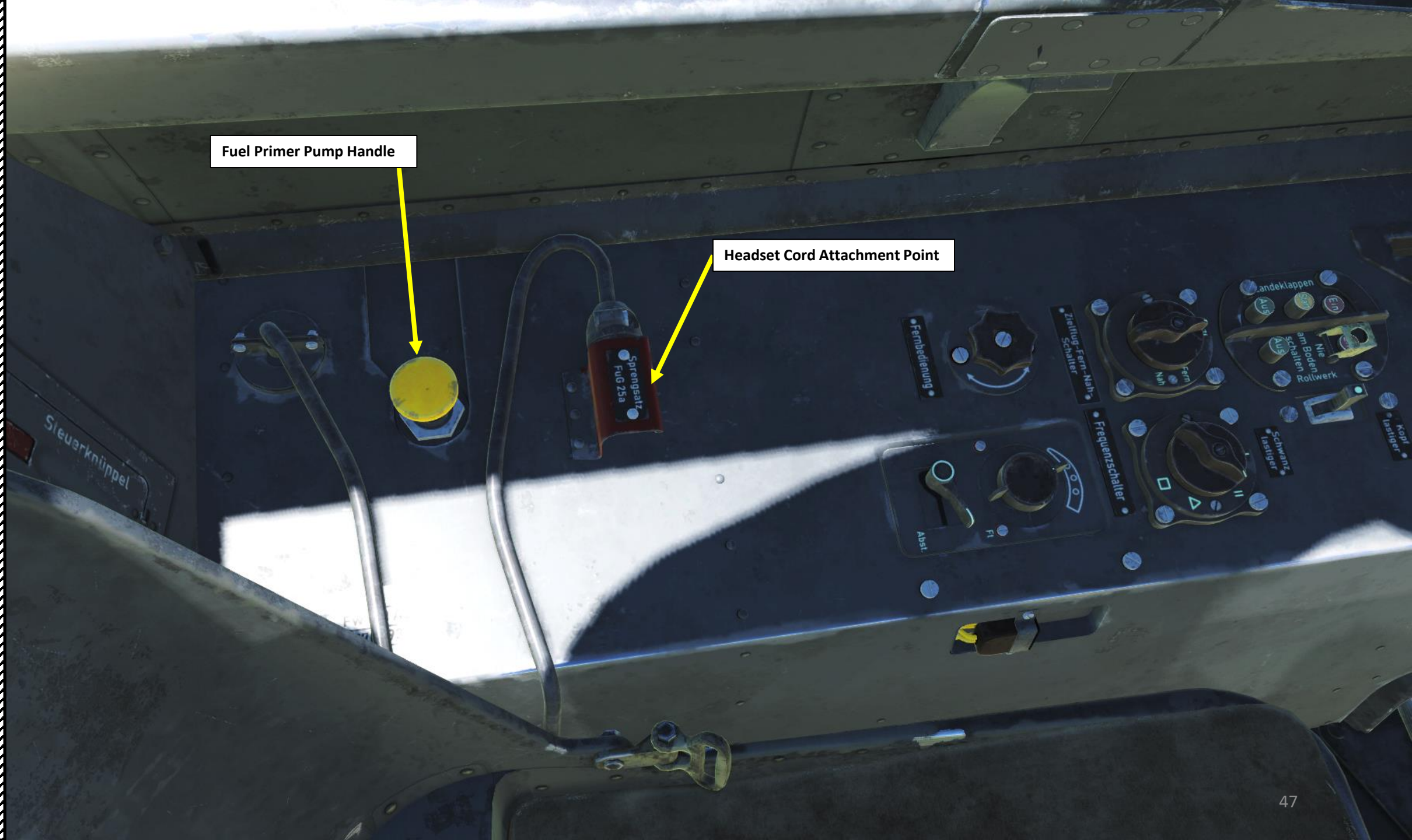



PART 3 – COCKPIT & EQUIPMENT



Achtung!

**Haubenabwurf
durch Sprengladung**

Abwurthebel nicht berühren. Im Probefall
vorherige Sicherung des Schlagbolzens

Radiator Flaps



Engine Intake

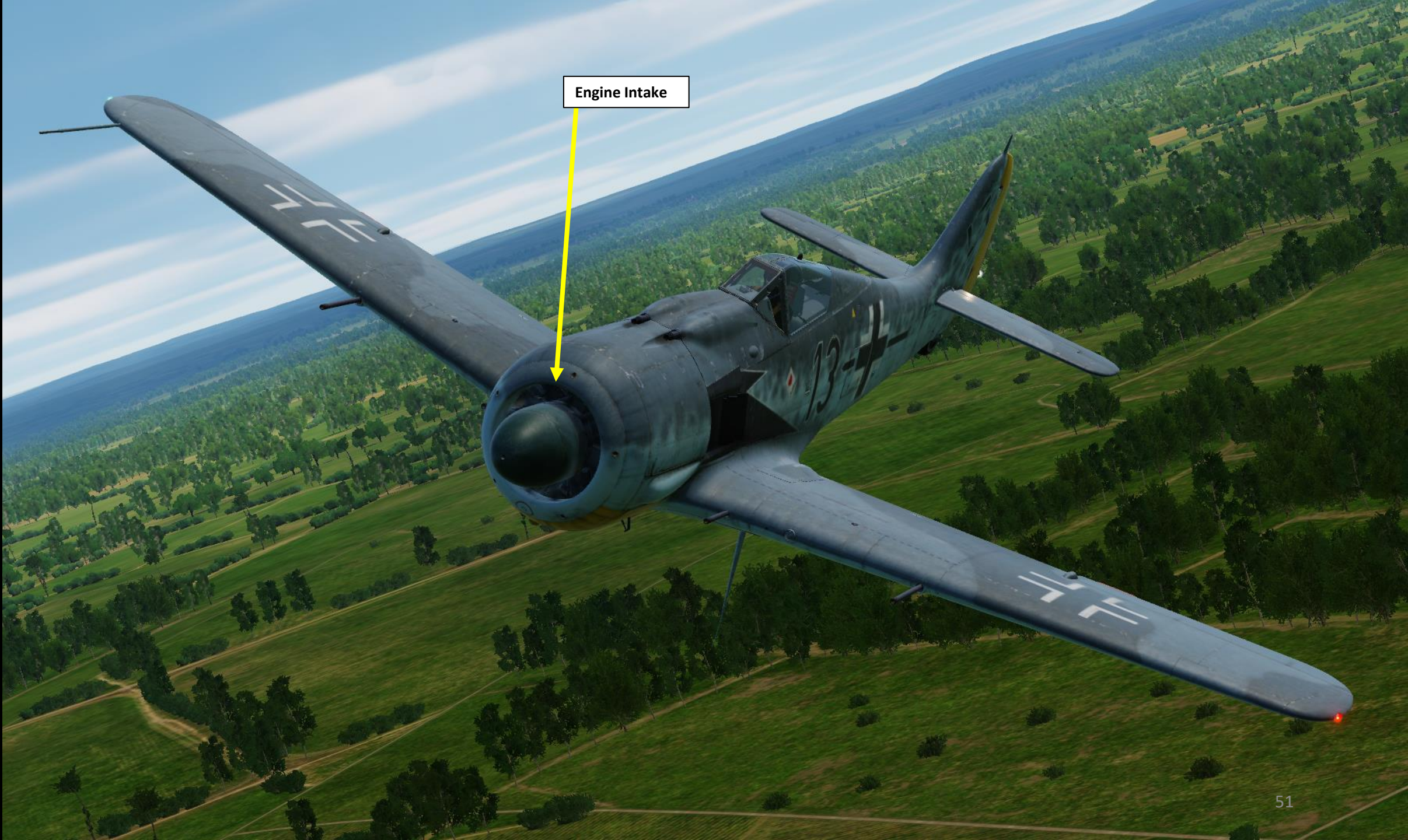

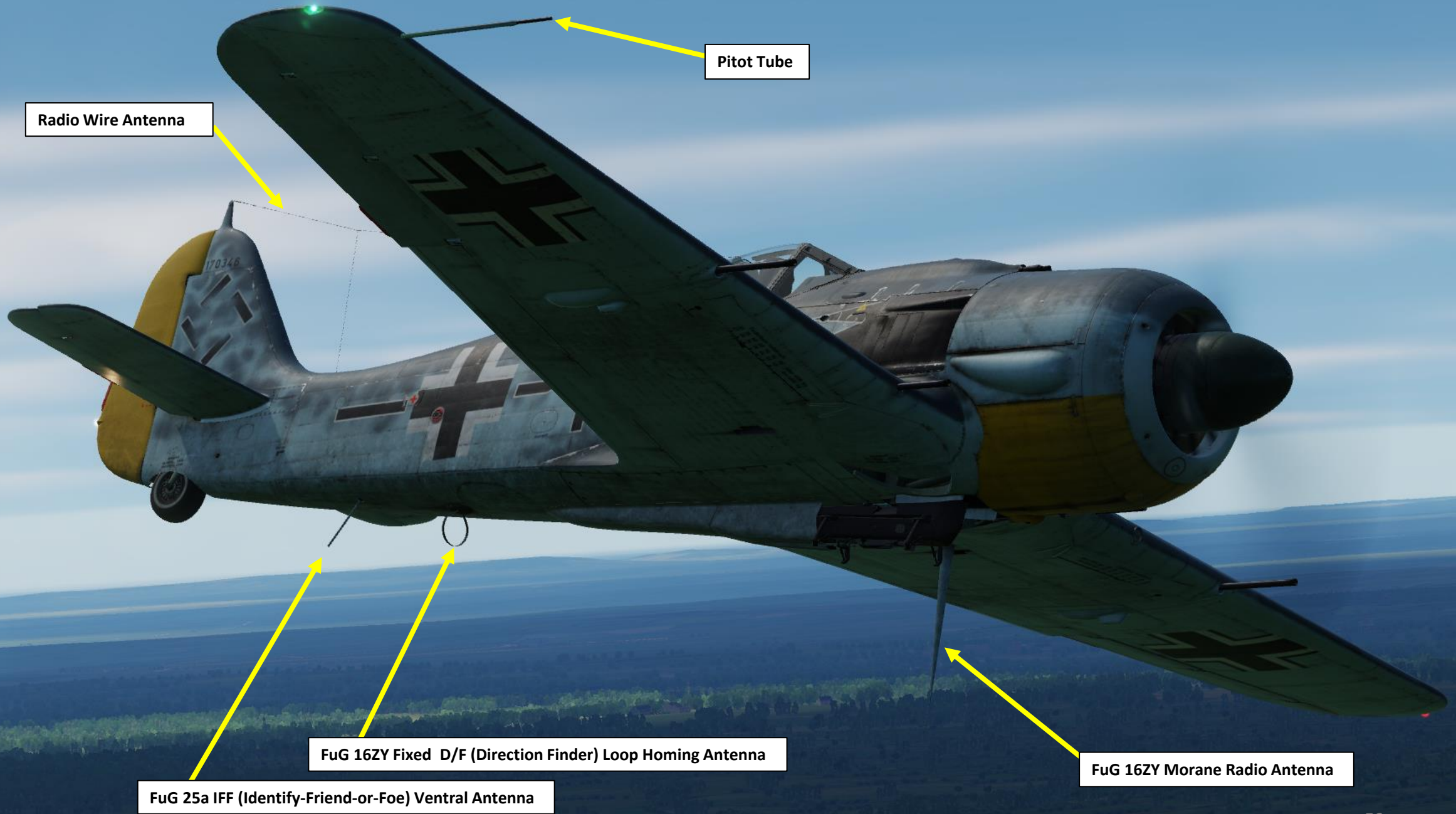

Pitot Tube

Radio Wire Antenna

FuG 16ZY Fixed D/F (Direction Finder) Loop Homing Antenna

FuG 25a IFF (Identify-Friend-or-Foe) Ventral Antenna

FuG 16ZY Morane Radio Antenna



Flaps
• *Electrically actuated*

Mechanical (Right) Landing Gear Position Indicator



Flaps Position Indicator (deg)





Main Landing Gear
• *Electrically actuated*

Retractable Tailwheel
• *Electrically actuated*



Green Navigation Light

White Navigation Light

Navigation Lights (Kennlichter)
Circuit Breaker

Red Navigation Light



Cabin Illumination Lamps
• Blue light

Cabin Illumination (Gerätebrett)
Circuit Breaker



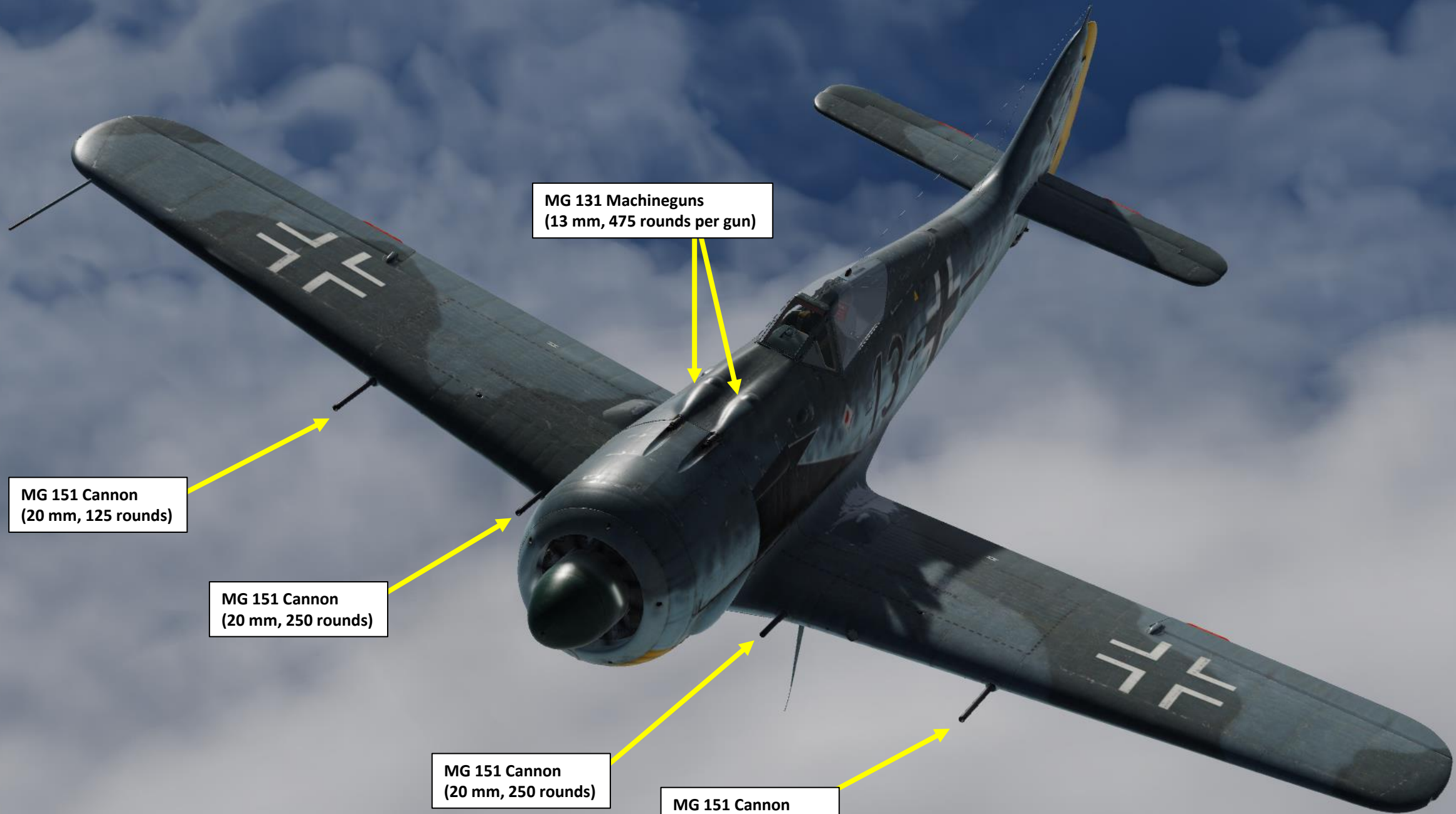

MG 131 Machineguns
(13 mm, 475 rounds per gun)

MG 151 Cannon
(20 mm, 125 rounds)

MG 151 Cannon
(20 mm, 250 rounds)

MG 151 Cannon
(20 mm, 250 rounds)

MG 151 Cannon
(20 mm, 125 rounds)

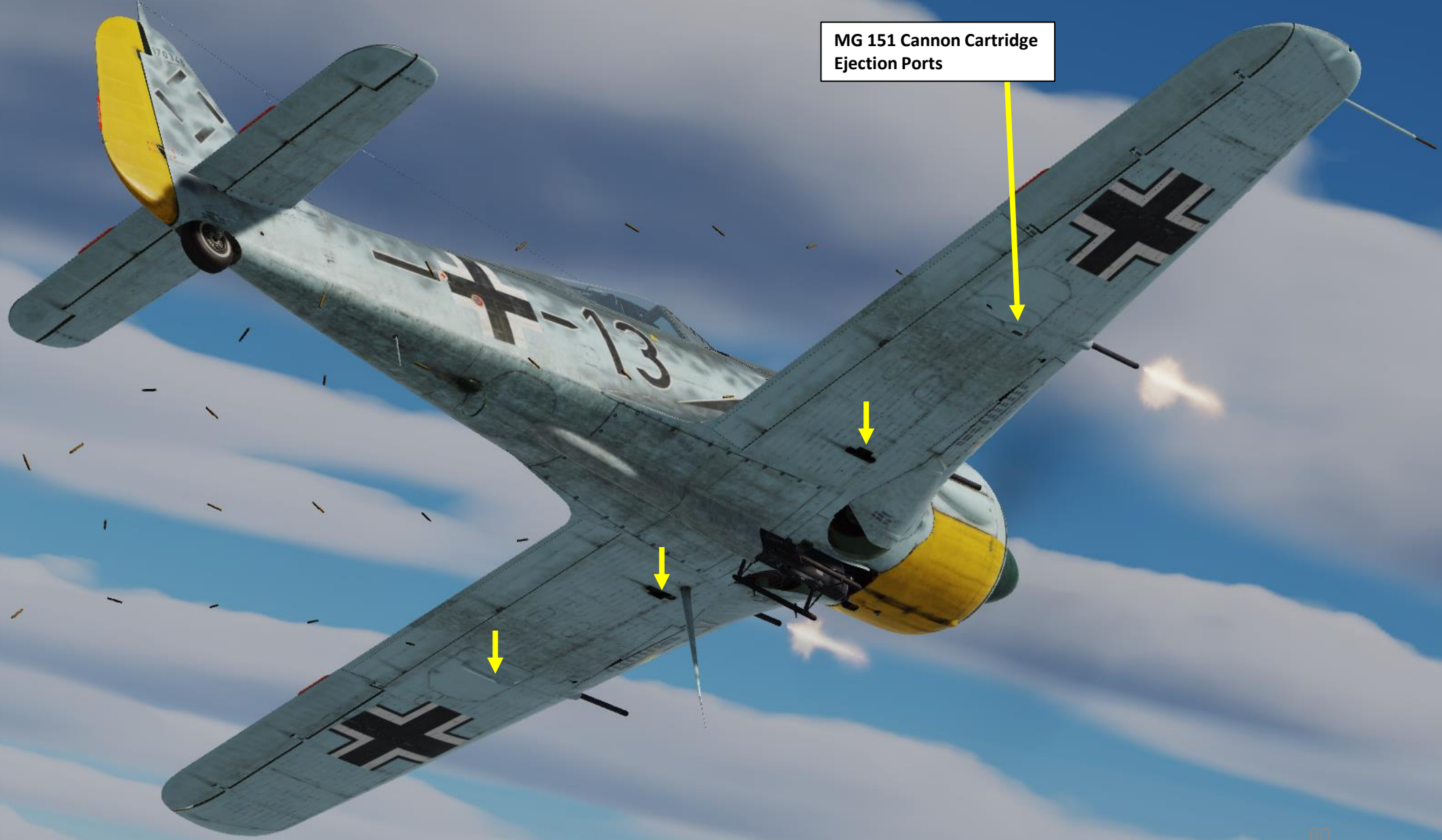

MG 151 Cannon Cartridge
Ejection Ports



SC-250 Bomb

BR 21 Werfer-Granate Rocket (21 cm)



Bomb Rack



External Fuel Drop Tank
(300 L)



FW190-A8
ANTON

PART 3 – COCKPIT & EQUIPMENT





PRE-FLIGHT



PRE-FLIGHT

1. Click on both the forward and aft circuit breaker panels to open them.



PRE-FLIGHT

2. On the Front Circuit Breaker Panel, set the following circuit breakers – ON (IN)
 - a) Battery (*Sammler*)
 - b) Engine Generator
 - c) FuG 25a IFF (Identify-Friend-or-Foe)
 - d) Ignition Starter (*Zündung Anlasser*)
 - e) Pitot Tube Heater (*Staurohrheizung*)
 - f) Clothes Heating (*Heizbekleidung*)
 - g) Cabin Illumination (*Gerätebrett*)
 - h) **Optional:** Navigation Lights (*Kennlichter*)
 - i) Flight Instruments Power (*Meßanlage Überwachung*)
 - j) Gunsight & Gun Camera (*Bild-und-Zielgerät*)
 - k) Drop Ordnance & Optional Armament (*Abwurfwaffe*)
3. **Optional:** If you want to use External Power, call the ground crew to connect a Ground Power Unit. Then, set the Battery (*Sammler*) Circuit Breaker OUT (OFF), and set the C1 External Power (*Außenanschluß*) Circuit Breaker IN (ON). Otherwise, the engine starter will run on battery power. In this tutorial, we will set the Battery Switch ON and let the engine starter run on battery power alone.

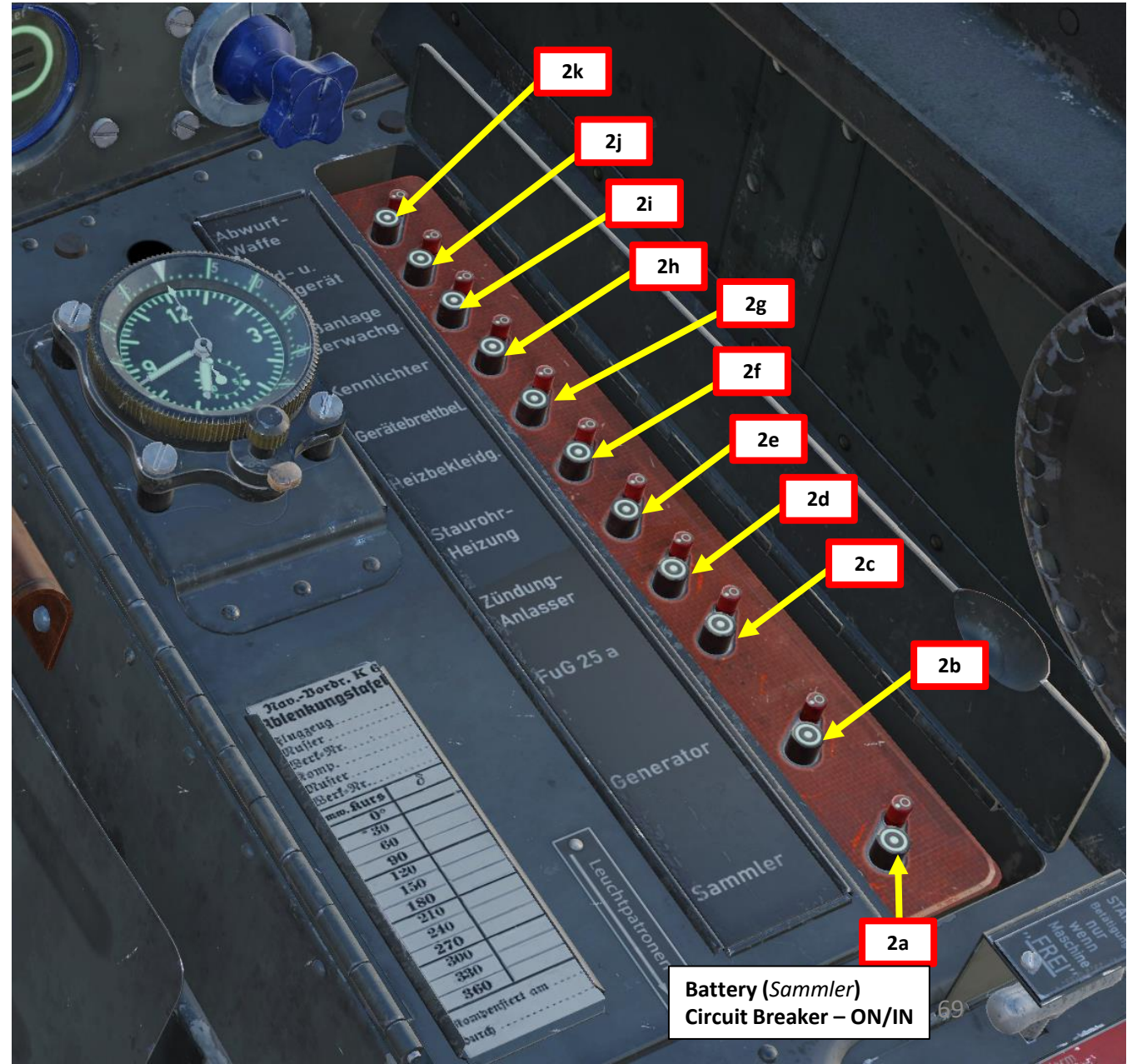
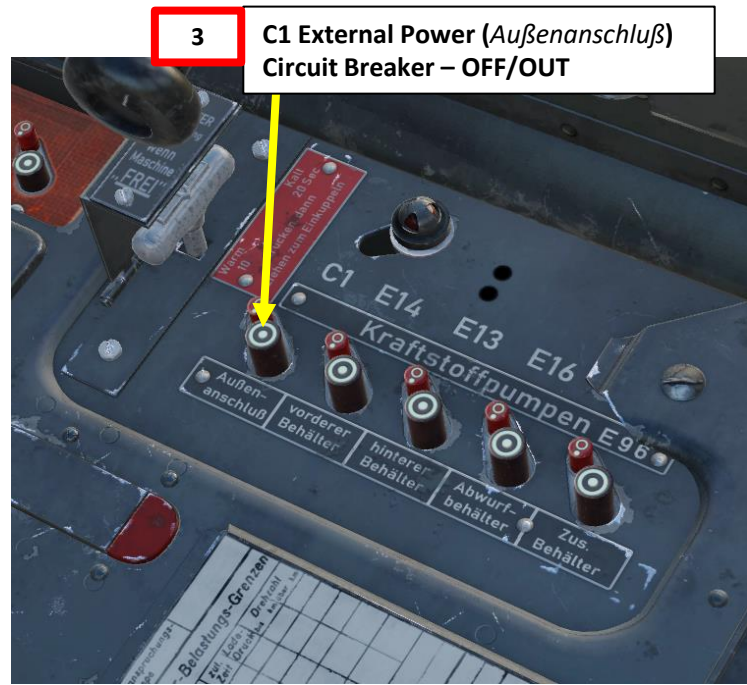

PRE-FLIGHT

4. On the Aft Circuit Breaker Panel, set the following circuit breakers – ON (IN)
 - a) FuG 16 ZY Radio (*FT-Anlage, Funktelefonie Anlage*)
 - b) Landing Gear Drive (*fahrwerks Antrieb*)
 - c) Landing Flaps Actuation (*Landeklappen Betätigung*)
 - d) Propeller Pitch Drive (*Verstellschraube*)
 - e) Propeller Pitch Controls (*Verstellschraube*)
 - f) Horizontal Stabilizer Trim (*Höhentrimm*)
 - g) Artificial Horizon (*Wendehorizont*)
 - h) Engine Generator (*Drehstrom Umformer*)
 - i) Repeater Compass (*Kompaß Anlage*)
 - j) Landing Gear Actuation (*Fahrwerks Betätigung*)
5. On the Aft Circuit Breaker Panel, make sure the FuG 25a Sprengung (IFF Self-Destruct) circuit breaker is OFF (OUT).
6. Set Armament Circuit Breakers – IN (ON)
 - a) P80: Outer Wing Armament (*Außenflügel*)
 - b) P1: Inner Wing Armament (*Innenflügel*)
 - c) P2: Engine-Mounted Armament (*Rumpf Motor*)

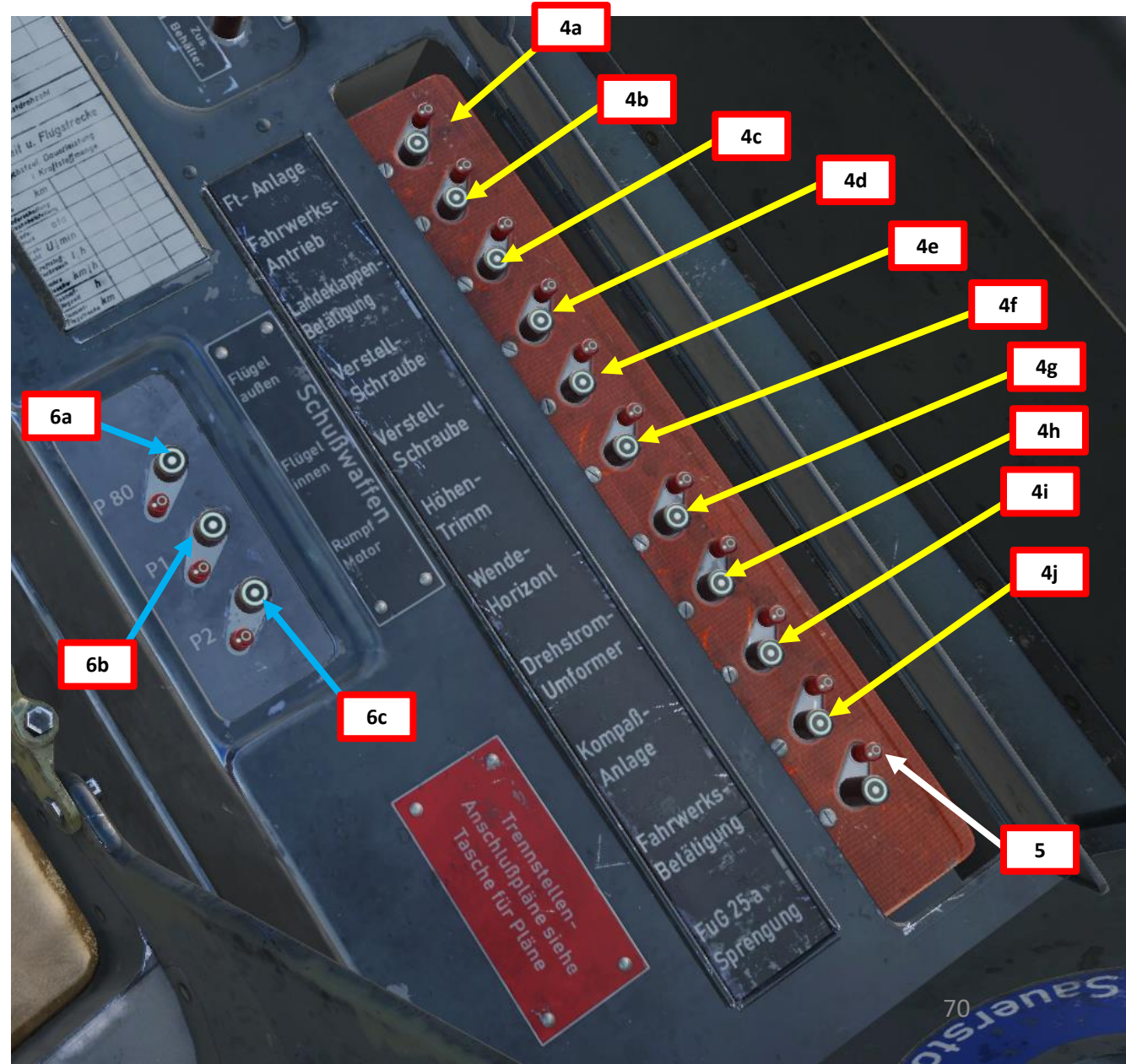

PRE-FLIGHT

7. Check fuel in Rear (*Hinten*) and Forward (*Vorn*) tanks
8. Set Oxygen Valve – OPEN (Rotate handle clockwise)
 - Confirm valve opens correctly with the Oxygen Flow Indicator and Oxygen Pressure Indicator gauges
9. Ensure elevator, aileron and rudder controls are working by moving stick and rudder pedals

Fuel Gauge Indication Selector

- Left: Vorn = Front
- Middle: No Tank Selected
- Right: Hinten = Rear

7

Note: If an external drop tank is installed, selector should be set to "HINTEN" (Rear) since drop tanks feed into the rear tank.

Fuel Gauge (x100 Liters)

- Vorn/Front Tank Capacity: 232 L (172 kg)
- Hinten/Rear Tank Capacity: 292 L (216 kg)
- Total Capacity: 524 L (388 kg)

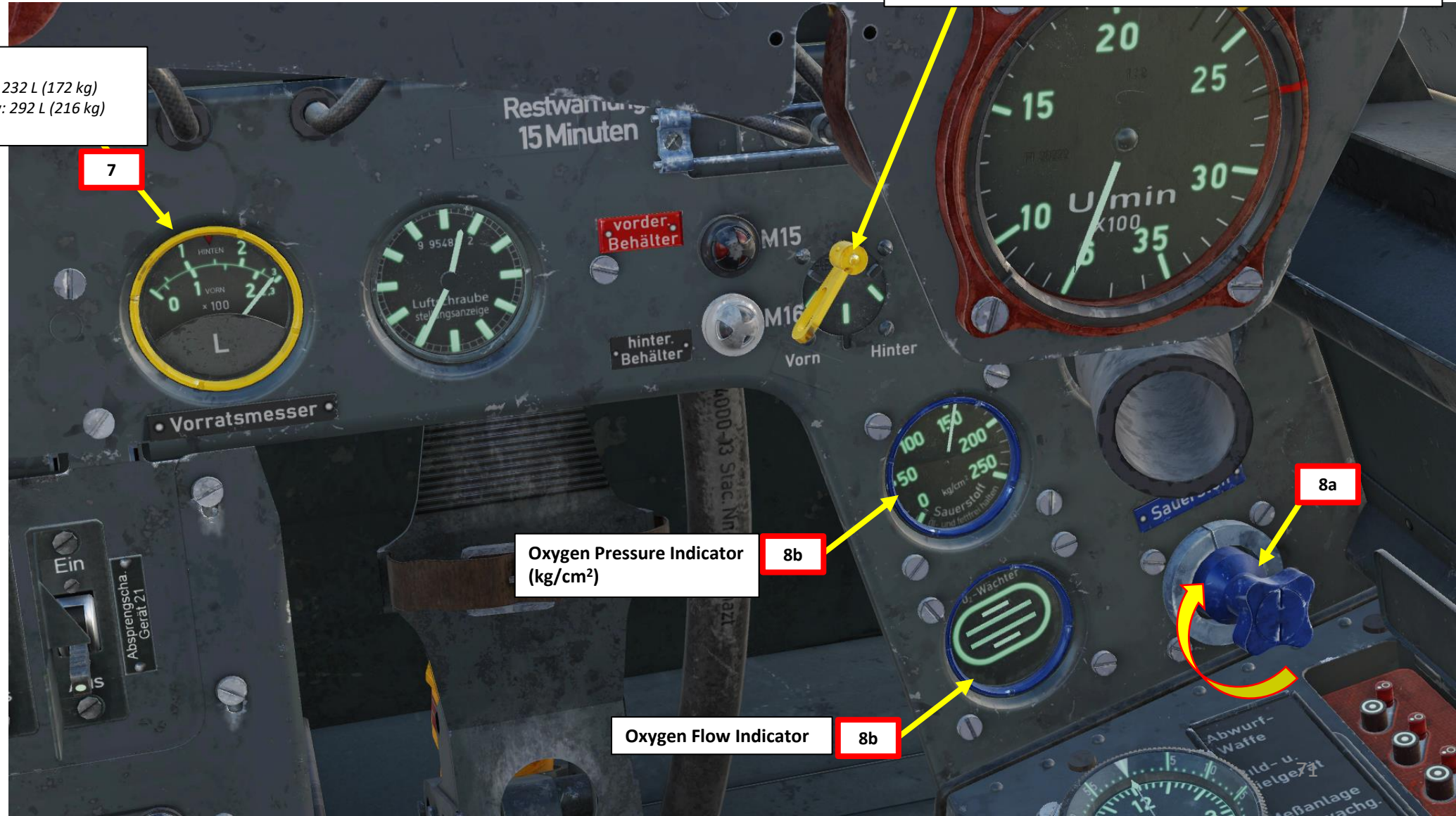

7

Oxygen Pressure Indicator
(kg/cm²)

8b

Oxygen Flow Indicator

8b

8a

PRE-FLIGHT

10. Verify that wheel chocks are installed. If not, call your ground crew (Press “\” and then press “F8”) and press “F4” and “F1” to ask the crew to place the wheel chocks.

Main **10a**

- F1. Wingman...
- F2. Flight...
- F3. Second Element...
- F5. ATC...
- F8. Ground Crew... **10b**
- F12. Exit

2. Main. Ground Crew

- F1. Rearm & Refuel
- F2. Ground Electric Power...
- F3. Request Repair
- F4. Wheel chocks... **10c**
- F11. Previous Menu
- F12. Exit

3. Main. Ground Crew. Wheel chocks

- F1. Place **10d**
- F2. Remove
- F11. Previous Menu
- F12. Exit



Wheel Chocks

ENGINE START

1. Set fuel selector lever to “AUF” (OPEN, FULLY UP)
2. Set E14 (Front Tank, *vorderer Behälter*) and E13 (Rear Tank, *hinterer Behälter*) Fuel Pump (Kraftstoffpumpen) Power Switches – ON (IN)
3. Set E96 (Auxiliary) Fuel Pump (Kraftstoffpumpen) Power Switch – ON (IN)
4. If external drop tank is equipped, set E16 (Auxiliary Tank) Fuel Pump Power Switch – ON (IN).
 - If no external drop tank is equipped, leave E16 Switch to OFF (OUT).
5. Actuate the Primer handle to pump fuel into the engines 1 to 15 times depending on the outside air temperature.
6. Confirm that there is sufficient fuel pressure (needle should be between the two white marks)

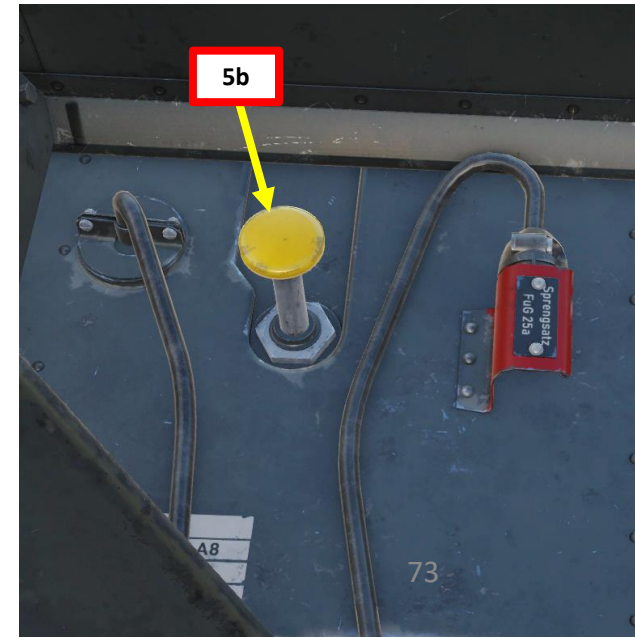
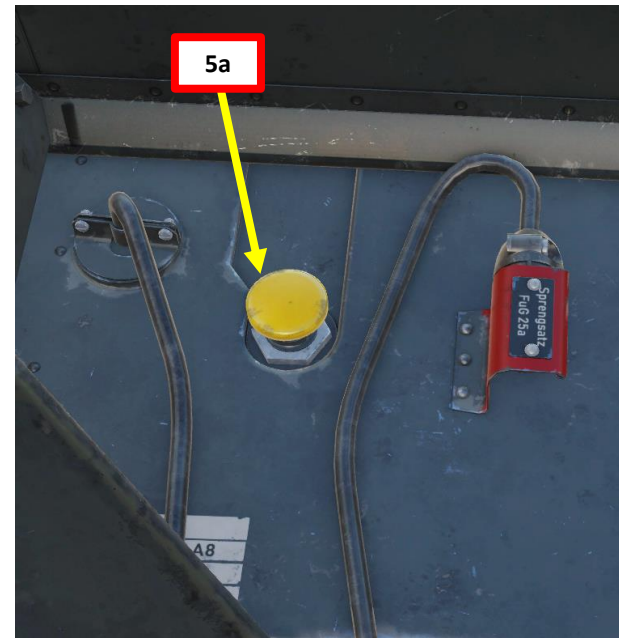
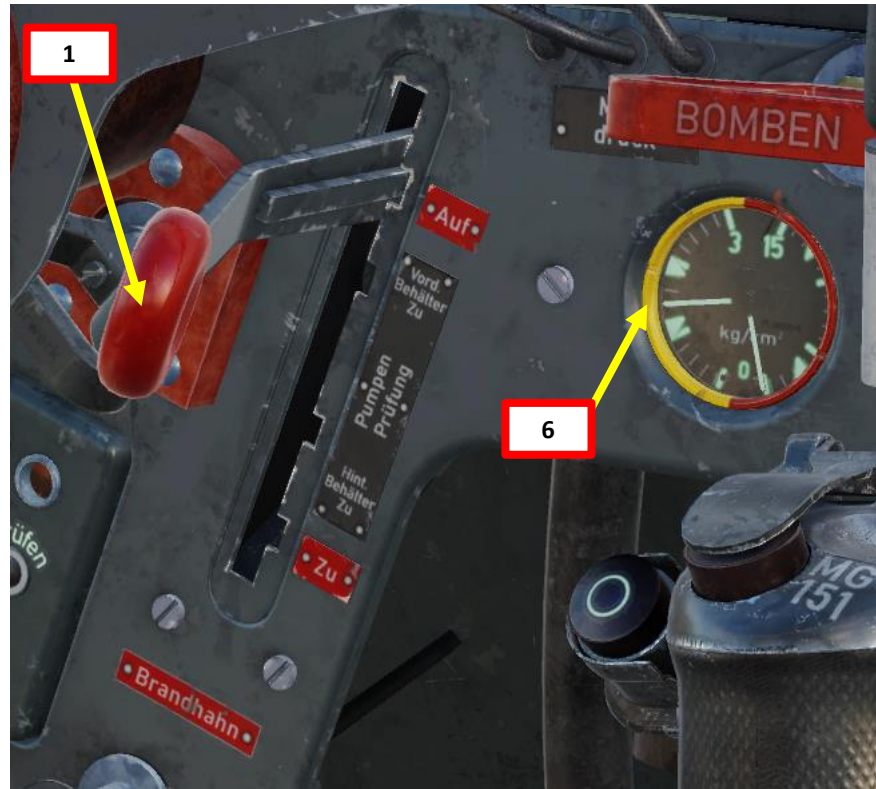
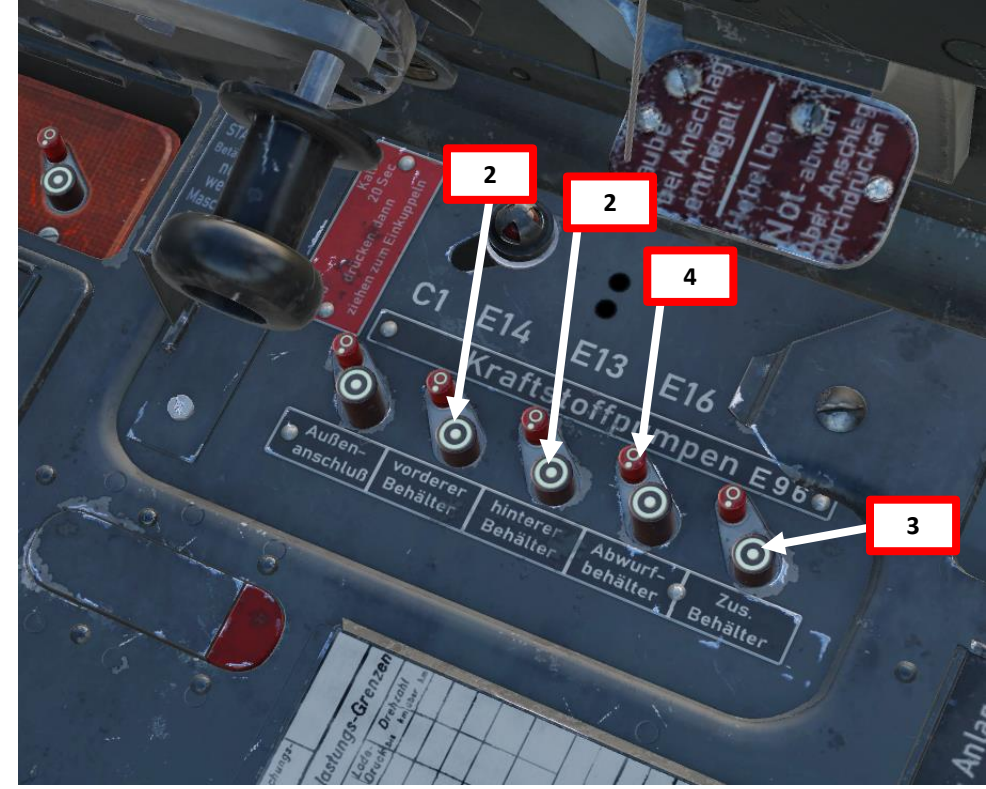

ENGINE START

7. Set Magnetos (Ignition) Switch – M1+M2
8. Set throttle to ANLASSEN (START-IDLE) by pressing RALT+HOME.
9. Set Propeller Governor Automation (Kommandogerät) switch to Manual (AFT), then use the Propeller Pitch Manual Rocker (Drehzahl) to increase Prop Pitch to 12:00 position (Engine RPM Up -> PageUp binding).
10. Set Propeller Governor Automation (Kommandogerät) switch to Automatic (FWD) and confirm that Prop Pitch needle moves to 12:35 position.

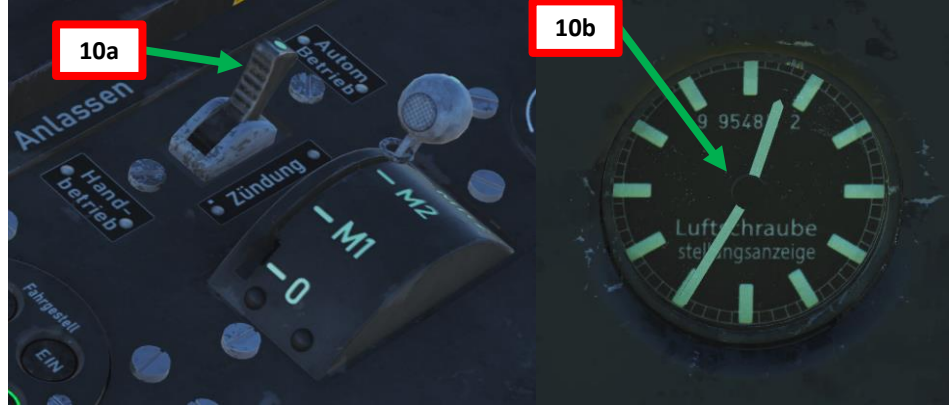
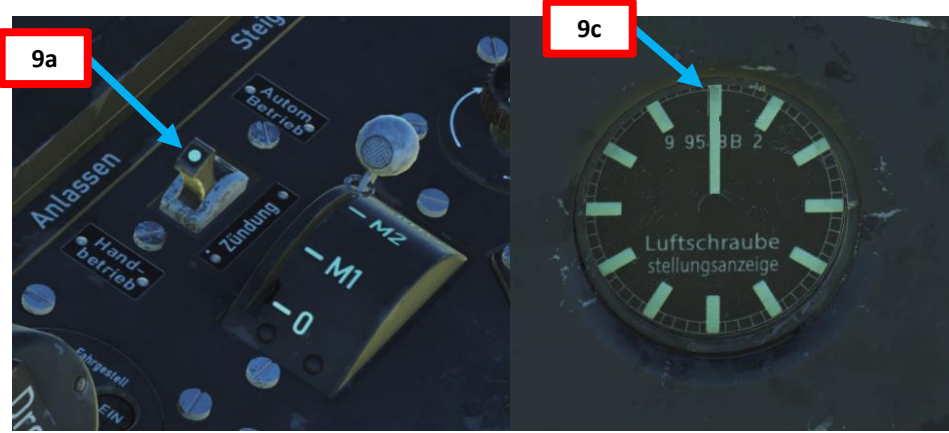

Propeller Governor Automation Switch (Kommandogerät Engine Control Mode Selector)
Fwd: Automatic Pitch Control
Aft: Manual Pitch Control

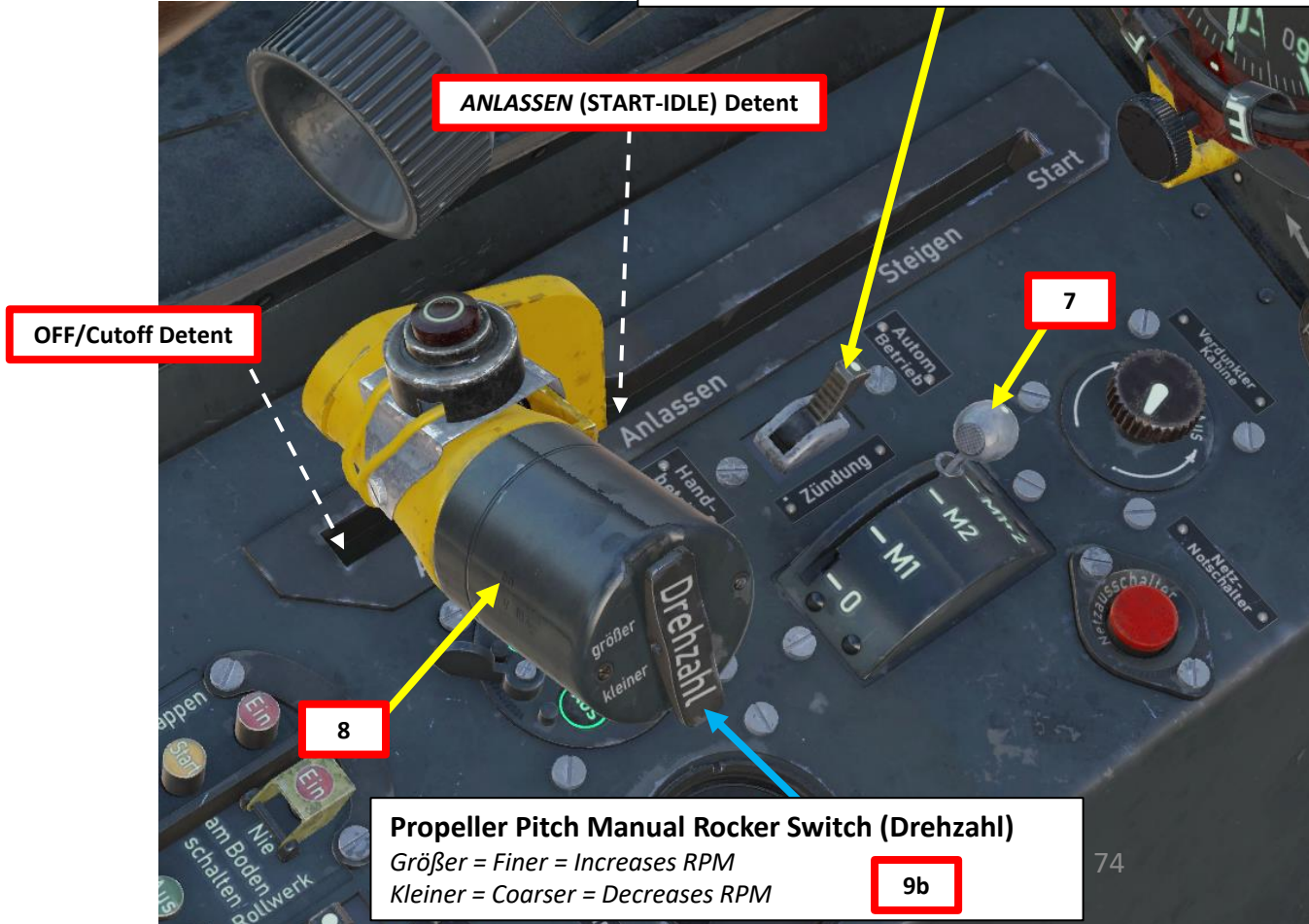

Propeller Pitch Manual Rocker Switch (Drehzahl)
Größer = Finer = Increases RPM
Kleiner = Coarser = Decreases RPM

ENGINE START

11. Verify that the propeller is clear and command « Clear prop! » to warn people around you that you are about to start the engine.
12. Flip starter cover.
13. Push down and hold the starter lever (left click) for 25 seconds. The inertial flywheel will crank up.
14. Pull the Starter Lever (Right Click) and hold it until the engine fires up.
15. After engine startup, keep the engine running at a setting of 500-600 RPM until the oil pressure indicator starts moving, then immediately increase the speed to 1200 rpm. If the arrow of the oil pressure indicator does not move within 15 seconds, stop the engine and call the personnel for repair.
16. *Optional:* If you have started your engine with ground power, give the signal for the ground personnel to disconnect the aircraft from the airfield power source.

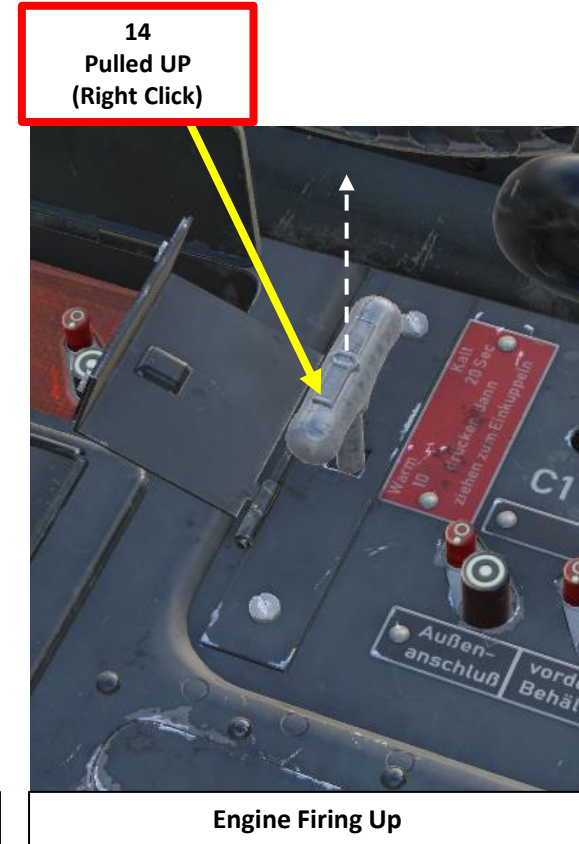

ENGINE START



POST-START

1. Engage wheel brakes by pressing down and holding the toe brake pedals.
2. Call your ground crew (Press “\” and then press “F8”) and press “F4” and “F2” to ask the crew to remove the wheel chocks.

Main 2a
 F1. Wingman...
 F2. Flight...
 F3. Second Element...
 F5. ATC...
 F8. Ground Crew... 2b
 F12. Exit

2. Main. Ground Crew
 F1. Rearm & Refuel
 F2. Ground Electric Power...
 F3. Request Repair
 F4. Wheel chocks.. 2c
 F11. Previous Menu
 F12. Exit

3. Main. Ground Crew. Wheel chocks
 F1. Place
 F2. Remove 2d
 F11. Previous Menu
 F12. Exit

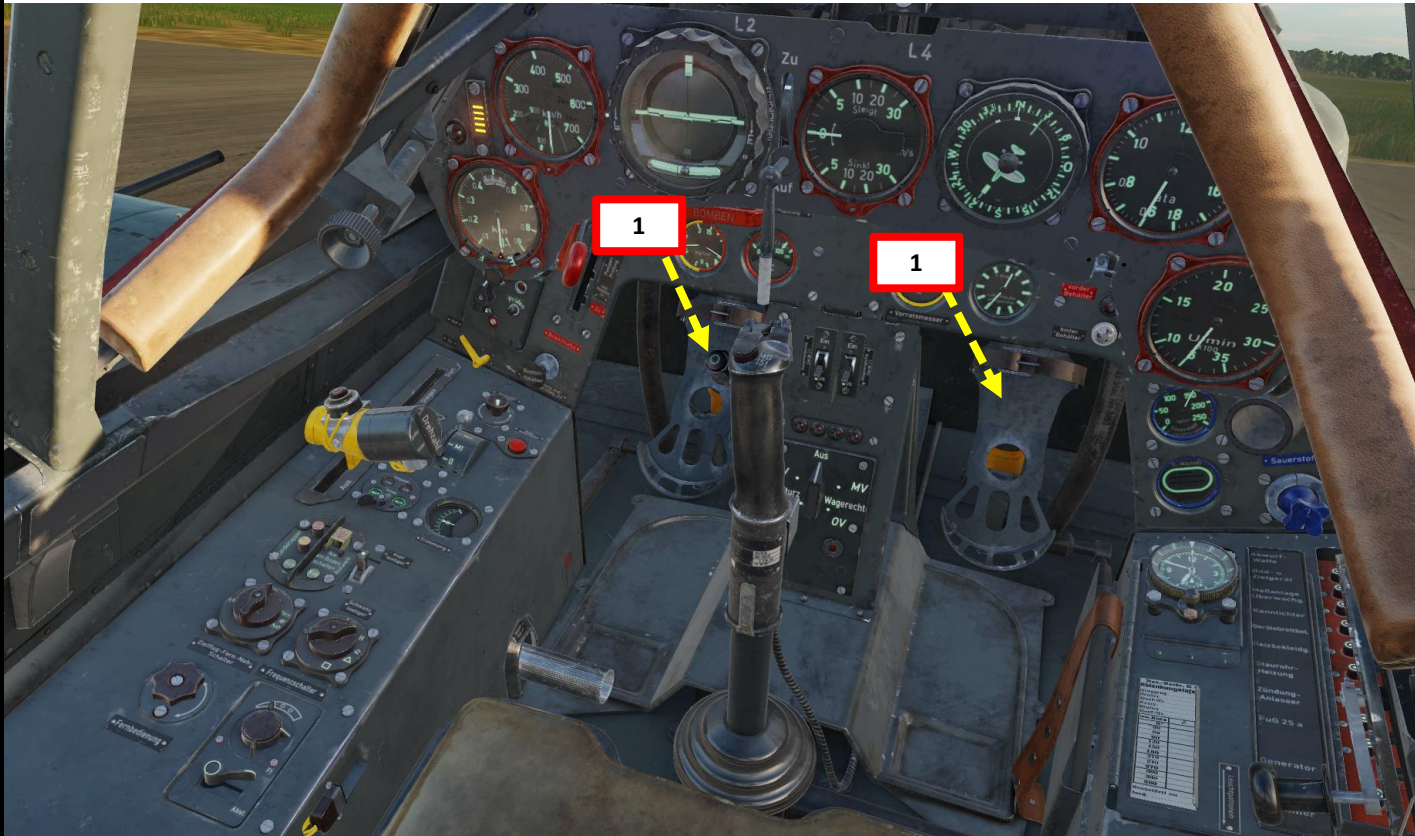

POST-START

3. Close your canopy by cranking the canopy handle (“LCtrl+C”).



POST-START

4. Uncage the Artificial Horizon by rotating the outer ring. In the uncaged position, the F (*Fest*, Caged) and L (*Los*, Uncaged) letters should be upside down.
5. Set FuG 16ZY Radio Homing Selector Switch - Ft: *Funktelefonie* / Radio Telephony
6. Set FuG 16ZY Radio Frequency Selector Switch – As required by mission briefing.
 - The "I" position is for "Y-Führungsfrequenz", or Management frequency, is used for communication within the flight or squadron.
 - The "II" position is for "Gruppenbefehlsfrequenz", or Group Order frequency, is used to communicate between several flights from different squadrons participating in a single raid.
 - The "Δ" position is for "Nah-Flugsicherungsfrequenz", or the **Air Traffic Control** frequency. It is used to communicate with the designated Air Traffic Controller.
7. Adjust FuG 16ZY Radio Volume Control – As required

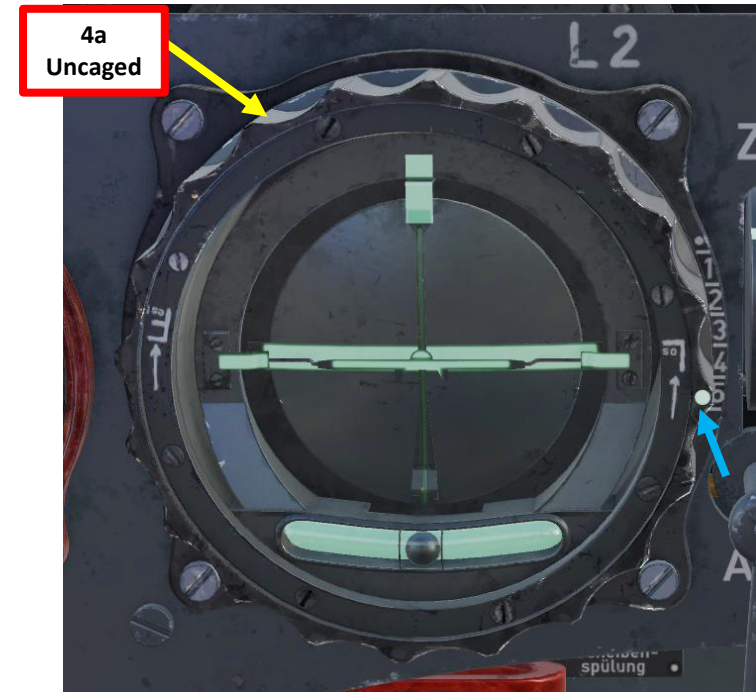
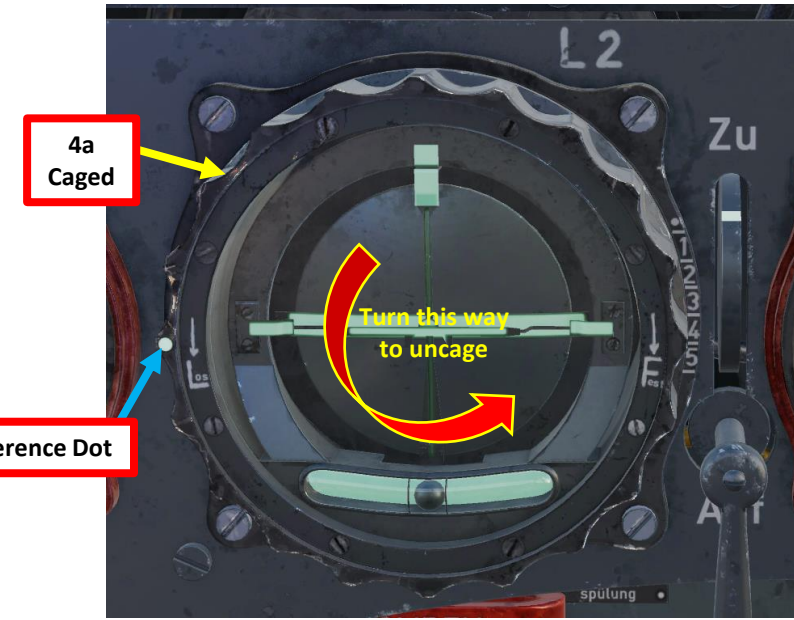
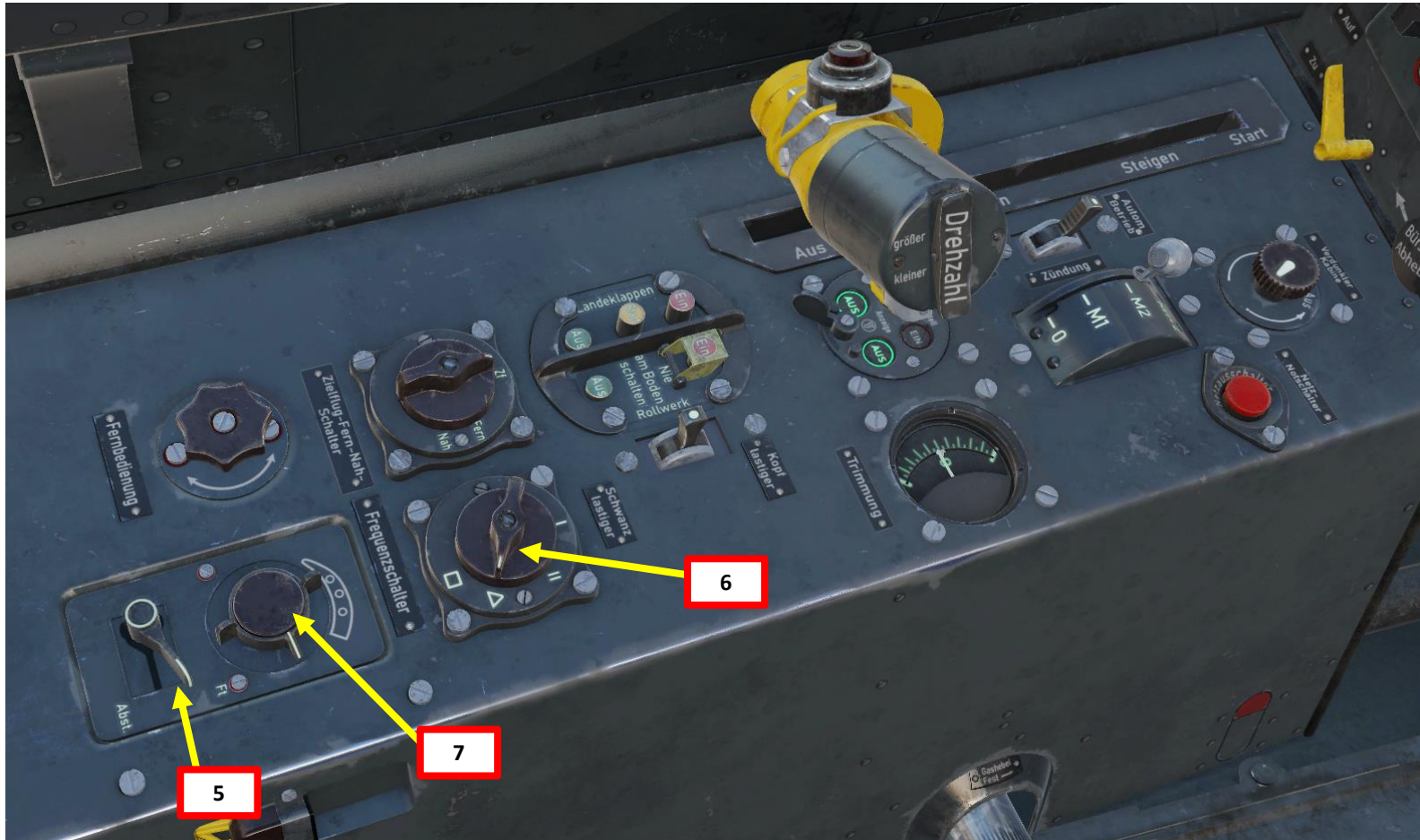

POST-START

- Use F10 key to display your map and airport information. Adjust QFE (Barometric Pressure) Setting to “0”. Alternatively, you can also match the altimeter reading to the airport elevation in meters.



Carpiquet		
ICAO	B-17	
COALITION	RED	
ELEVATION	187 ft ←	
RWY Length	5114 ft	
COORDINATES	49°10'15"N 00°26'45"W	
TACAN	--	
VOR	--	
RSBN	--	
ATC (MHz, AM)	4.025, 39.000, 118.550, 250.550	
RWYs	30	12
ILS	--	--
PRMG	--	--
OUTER NDB	--	--
INNER NDB	--	--
RESOURCES		



POST-START

- 9. Set Flaps (*Landeklappen*) – TAKEOFF (START) Position.
- 10. Verify that flaps position is 10 deg on the wing indicator.
- 11. Perform engine warm-up.



ENGINE WARM-UP

1. Hold pedal brakes and increase throttle to reach a RPM of about 1200.
2. Let the engine **oil temperature** warm up to at least 25 deg C. Engine operation at a RPM between 600 and 1100 must be avoided at all costs to prevent vibration damage to the engine impeller.
 - Keep radiator flaps fully closed for a quicker engine warm-up.
3. Once oil temperature is at least 25 deg C, increase throttle to 1400-1500 RPM until the **oil temperature** reaches between 40 and 45 deg C.
4. Open radiator flaps by rotating the Flaps Control Lever clockwise.
 - Open position is AUF.
 - Closed position is ZU.
5. Start taxiing when engine is warmed up.

Note: Attempting a takeoff with low oil temperature can lead to dire consequences. Waiting for proper engine warm-up is often overlooked by virtual pilots and the engine leaves no room for error when engine temperatures are concerned.

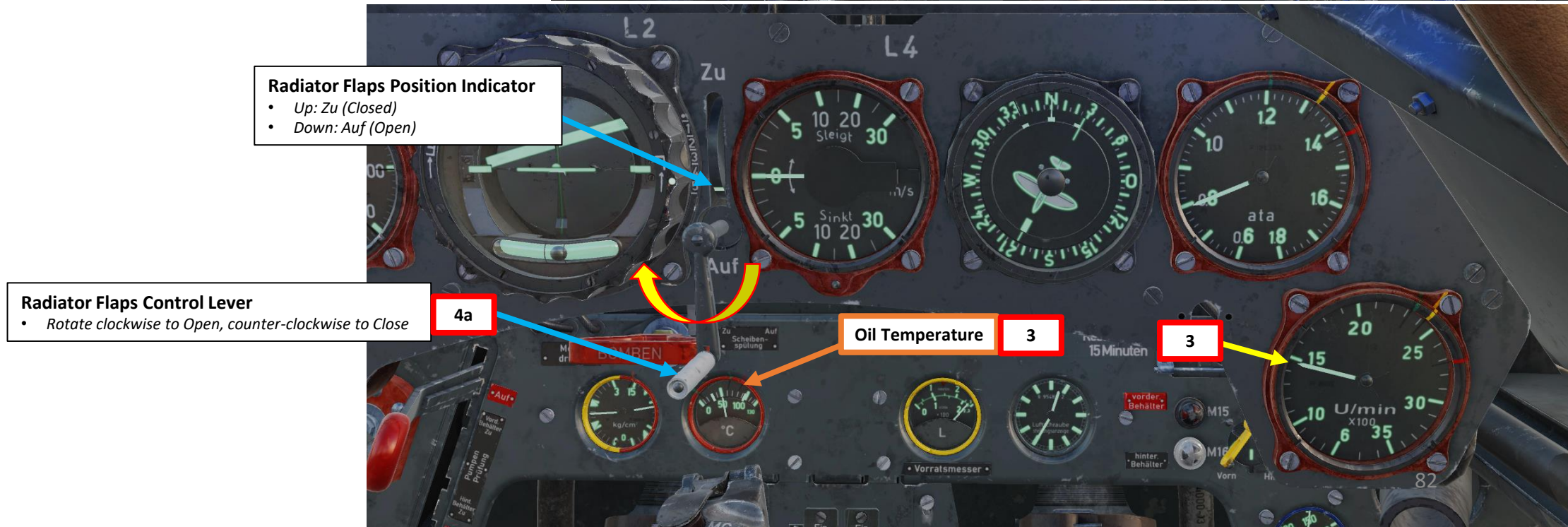
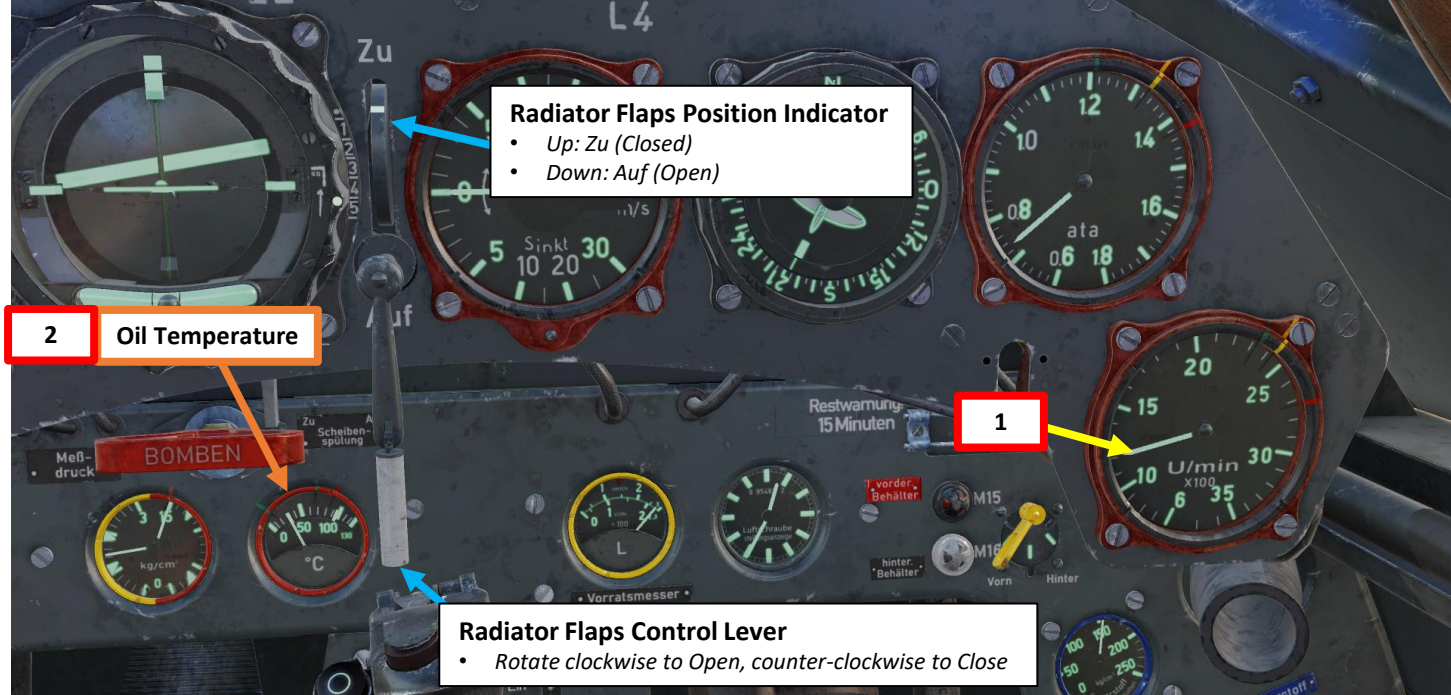

TAXI PROCEDURE

1. Verify that wheel chocks are removed.
2. Taxi to the runway when ready. Be careful not to overheat your engine on the ground.
3. Release wheel brakes, then throttle up to gain forward motion. Taxiing should be done at 15-20 km/h maximum.
4. The nose restricts forward visibility. This means that in taxiing, you must zig-zag (or "S-turn") continually. If you want to go straight, pull the stick fully back to lock the tailwheel in position.
5. To perform a turn, use differential braking by gently tapping the wheel brake pedal on the side you wish to turn. The disc-type wheel brakes are hydraulically actuated.



TAKEOFF PROCEDURE

1. Line up on the runway and verify the canopy is closed.
2. Once you are lined up with the runway, make sure your tailwheel is straight by moving in a straight line to straighten the wheel.
3. Keep your tailwheel locked on the ground by pulling your stick AFT.
4. Set flaps to TAKEOFF (Start) position by pressing the *Landeklappen* START button IN
5. Set Horizontal Stab trim to 0 deg
6. Flip Landing Gear Safety Cover UP

Flaps (Landeklappen) Control Buttons

- *Ein*: Flaps retracted
- *Start*: Takeoff Position (10 deg)
- *Aus*: Flaps Deployed (60 deg)

4

Landing Gear Control Buttons

- *Ein*: Gear Up
- *Aus*: Gear Down

Landing Gear Button Safety Cover

6

Horizontal Stabilizer Trim (Trimmung) Indicator (deg)

5b

Horizontal Stabilizer Trim Control Switch

- *Kopflastiger* = Nose Down
- *Schwanzlastiger* = Nose Up

5a

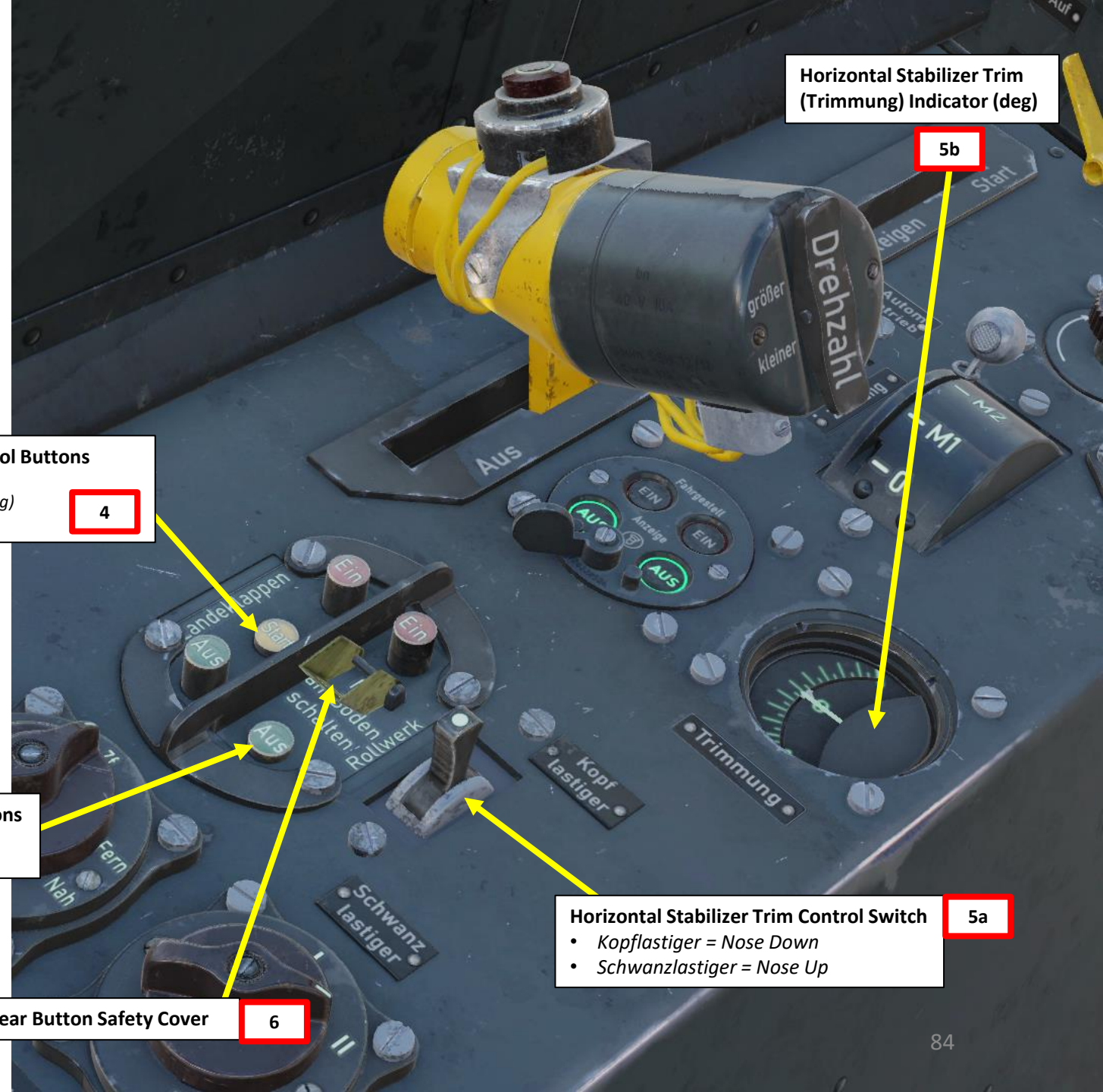

TAKEOFF PROCEDURE

- 7. Open radiator flaps fully by rotating the Flaps Control Lever clockwise.
 - Open position is AUF.
 - Closed position is ZU.

Radiator Flaps Position Indicator

- Up: Zu (Closed)
- Down: Auf (Open)

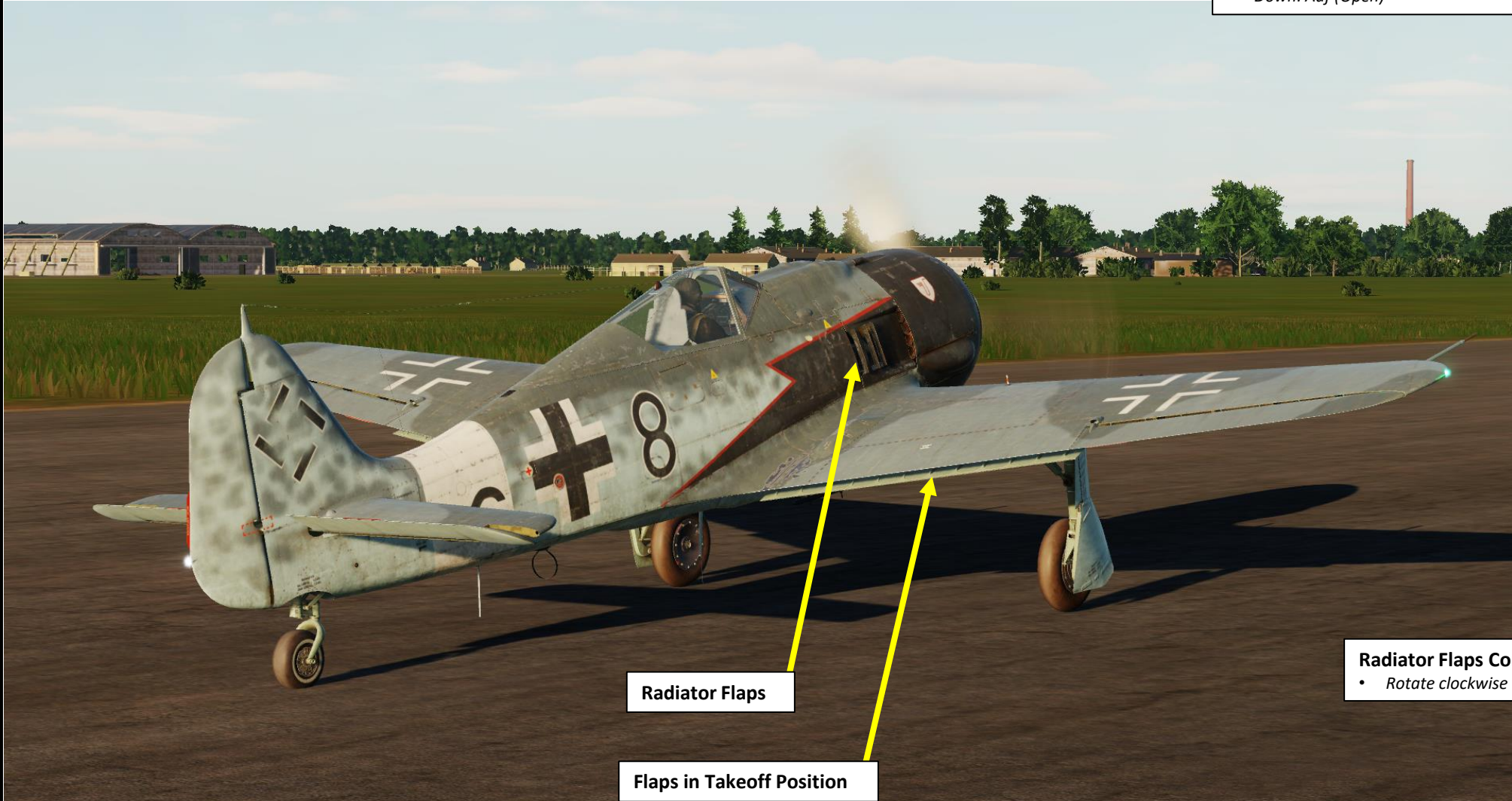

Radiator Flaps

Flaps in Takeoff Position



Radiator Flaps Control Lever

- Rotate clockwise to Open, counter-clockwise to Close

TAKEOFF PROCEDURE

- Adjust your course setting to the desired departure course (typically aligned with the runway's heading) by rotating the outer ring of the Repeater Compass.

Course Setting: North by default

7a

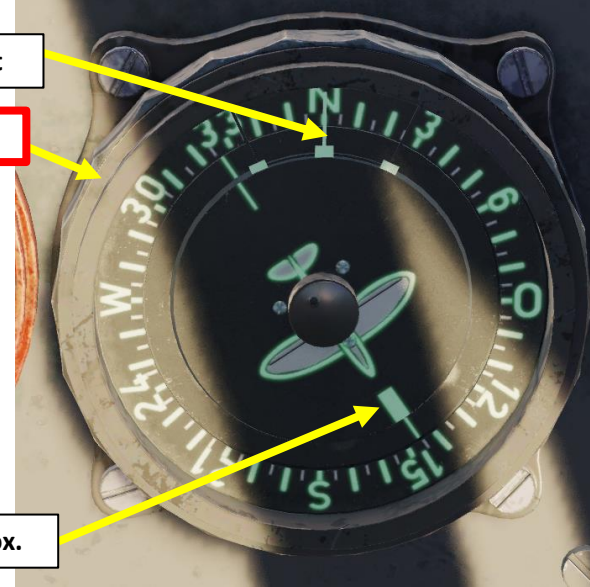

Aircraft Magnetic Heading: 140 Approx.

7b

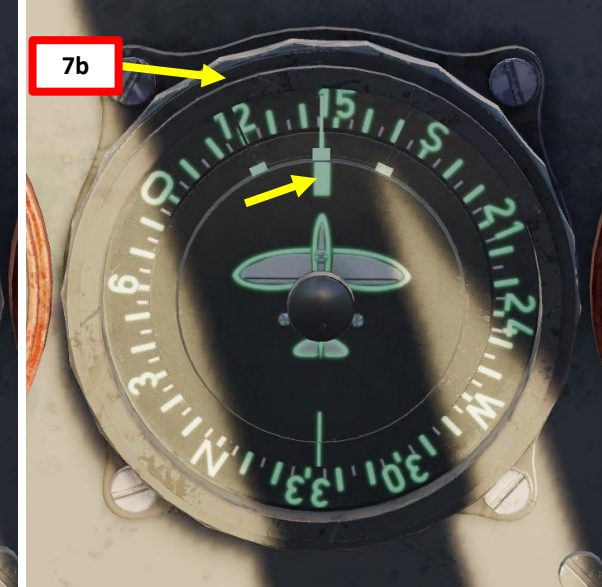

Carpiquet	
ICAO	B-17
COALITION	RED
ELEVATION	187 ft
RWY Length	5114 ft
COORDINATES	49°10'15"N 00°26'45"W
TACAN	--
VOR	--
RSBN	--
ATC (MHz, AM)	4.025, 39.000, 118.550, 250.550
RWYs	30 12
ILS	-- --
PRMG	-- --
OUTER NDB	-- --
INNER NDB	-- --
RESOURCES	

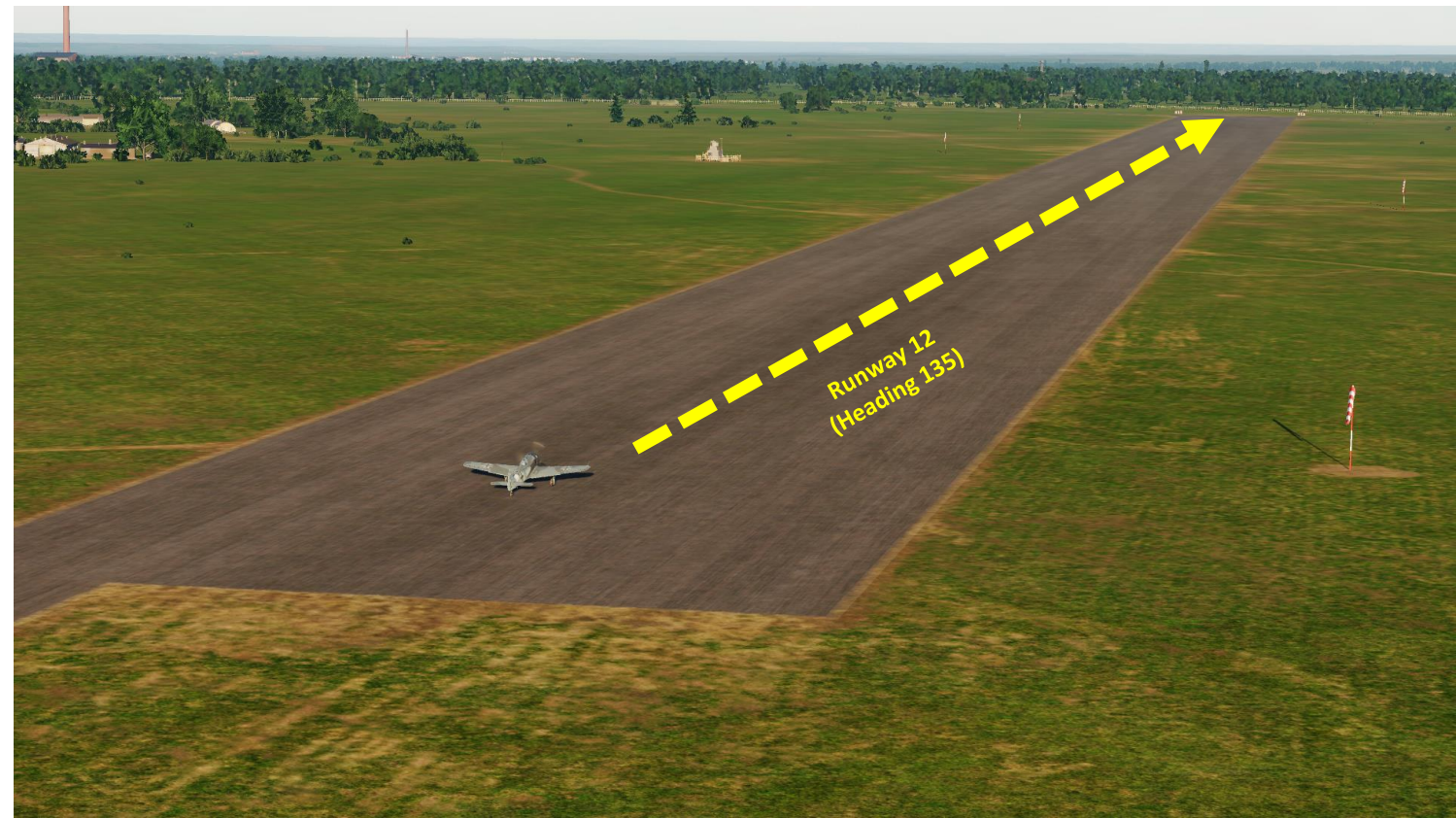

TAKEOFF PROCEDURE

9. Pull your stick fully AFT and hold it there to ensure the tailwheel stays straight.
10. Hold wheel brakes.
11. Throttle up to 2000 RPM, ensure engine parameters are within safety limits
12. Release brakes, then throttle up to 2700 RPM.
13. Do not use your brakes to steer your aircraft: use your rudder instead to make small adjustments.
14. At 170-180 km/h, center your control stick to allow you to pick up more airspeed. Your tailwheel should begin to rise. Make sure that your propeller does not strike the ground.
15. Rotate at 200 km/h.



Tailwheel



TAKEOFF PROCEDURE

16. Raise landing gear by pressing the *Rollwerk EIN* button IN before reaching 250 km/h.

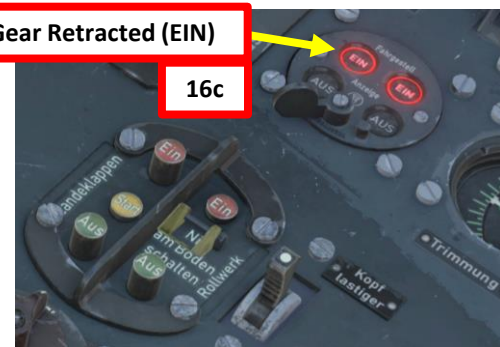
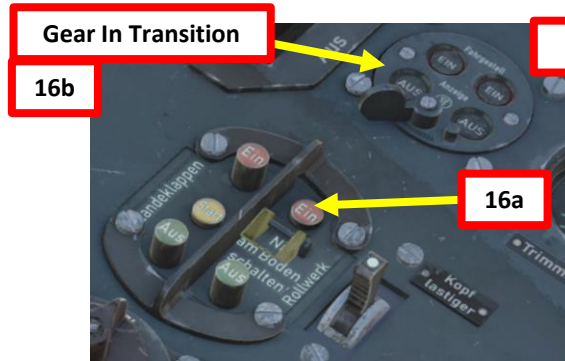

TAKEOFF PROCEDURE

17. Raise flaps by pressing the *Landeklappen* EIN button IN before reaching 250 km/h.



TAKEOFF PROCEDURE

18. Within three minutes after takeoff, reduce power to 2400 RPM (1.4 ATA Manifold Pressure) and start climbing.
19. Optimal climb speed is 280-290 km/h with a climb power of 2700 RPM.



LANDING PROCEDURE



LANDING PROCEDURE

1. Enter downwind leg at 300 m altitude.
2. Deploy landing gear in LANDING (AUS) position when below 250 km/h.
3. Extend flaps in LANDING (AUS) position when below 250 km/h.
4. Open radiator flaps fully by rotating the Flaps Control Lever clockwise.
 - Open position is AUF.
 - Closed position is ZU.

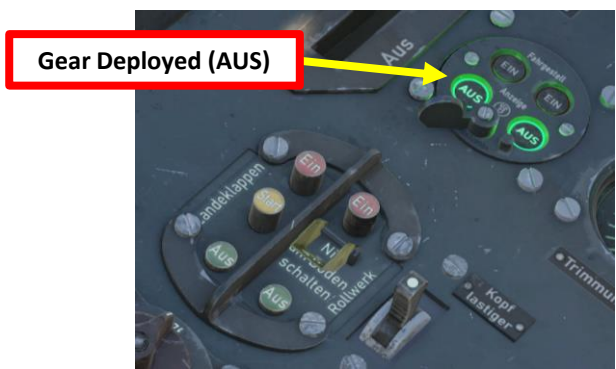
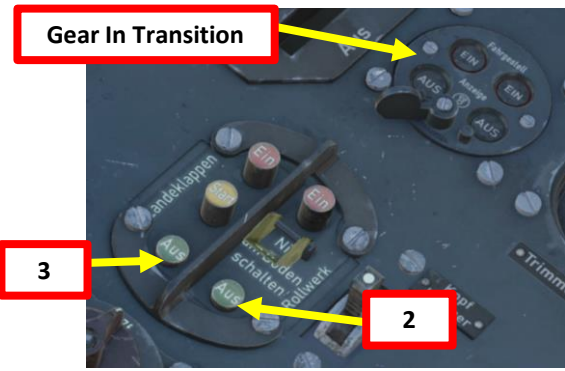
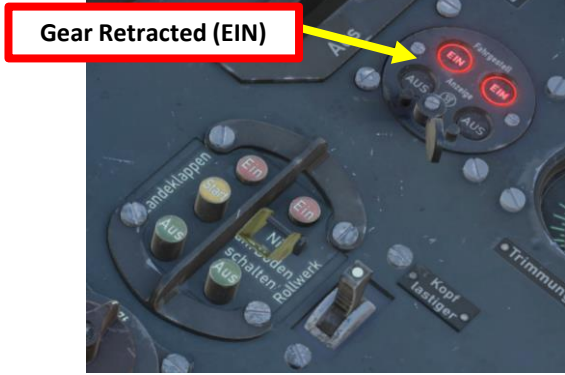
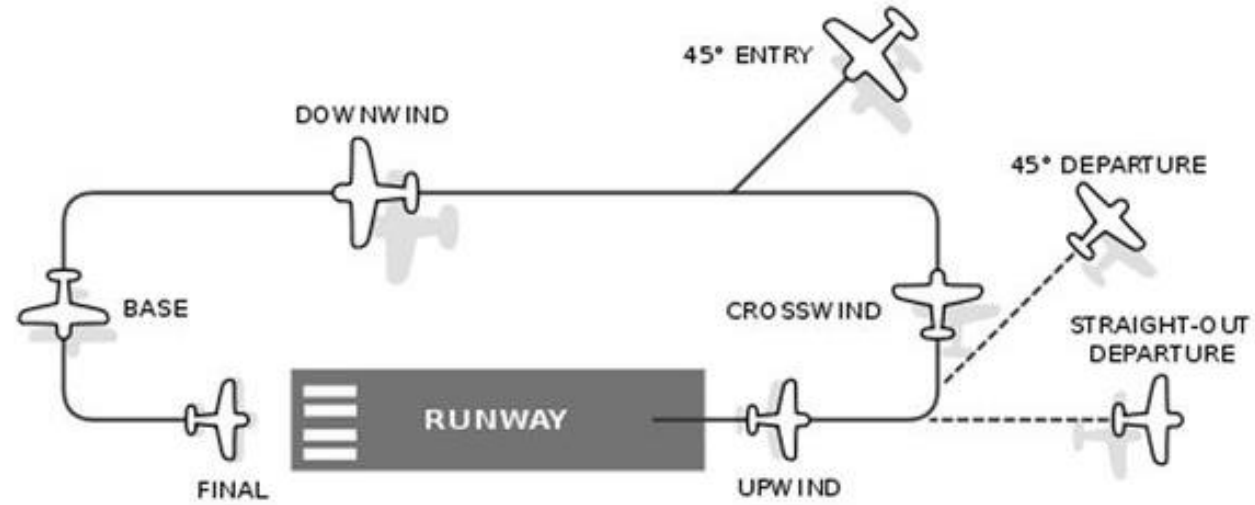

LANDING PROCEDURE

5. After turning on final, keep your nose aimed to the end of the runway, not the beginning. You tend to go where you aim.
6. Approach the airfield with a speed of 220 km/h, and a sink rate between 2.5 and 5 m/s.
7. Reach the runway with a speed of approx. 200 km/h and a sink rate of 2.5 m/s.
8. Touchdown with a speed of 160-180 km/h with IDLE throttle. Do not start pulling on the stick to lock your tailwheel down yet: you can still generate enough thrust to bounce, stall and crash at any speed over 170 km/h if you are not careful. Glide your way through the runway... gravity and deceleration will keep you on a straight trajectory.
9. When decelerating to 100 km/h or less, lock your tailwheel by pulling back on your stick.
10. Do not use your brakes to steer the aircraft yet: use small rudder input instead.
11. When you start losing rudder authority (due to the decreasing airspeed), gently tap your brakes to slowly bring the airplane to a full stop.



LANDING PROCEDURE





LANDING PROCEDURE



LANDING PROCEDURE



Landing Speed

Weight	Speed	Weight	Speed
Kg	Kph	Lbs.	Mph
3500	159	7600	98
3600	161	7800	100
3700	163	8000	101
3800	165	8200	102
3900	167	8400	103
4000	169	8600	105
4100	171	8800	106
4200	173	9000	107
4300	175	9200	108
4400	177	9400	109
4500	179	9600	111
5000	180	9800	112

Distance and speeds of takeoff and landing roll

Weight, kg	Takeoff roll, m		Rate of climb after takeoff, m/s (flaps at 10°)	Landing roll, m		Roll time, seconds	
	Concrete	Grass		Concrete	Grass	Concrete	Grass
4000	640	660	11	380	400	14,5	15,5
4500	780	820	9	520	560	18	19,5
5000	960	1110	7	680	730	22	24
5500	1200	1280	5	880	960	26,5	29,5

BMW 801D-2 ENGINE

The Anton's powerplant consists of a 14-cylinder two-row radial BMW 801D-2 engine with a two-speed supercharger, a gearbox and a 12-blade cooling fan. The engine drives a three-bladed constant speed propeller. The BMW 801D-2 that delivers approximately 1,500 horsepower at 2,400 RPM. Maximum emergency power at level flight is 1,705 horsepower at 2,700 RPM. The Kommandogerät control unit monitors and automatically adjusts the propeller speed, boost, fuel mixture status, ignition delay and supercharger mode.

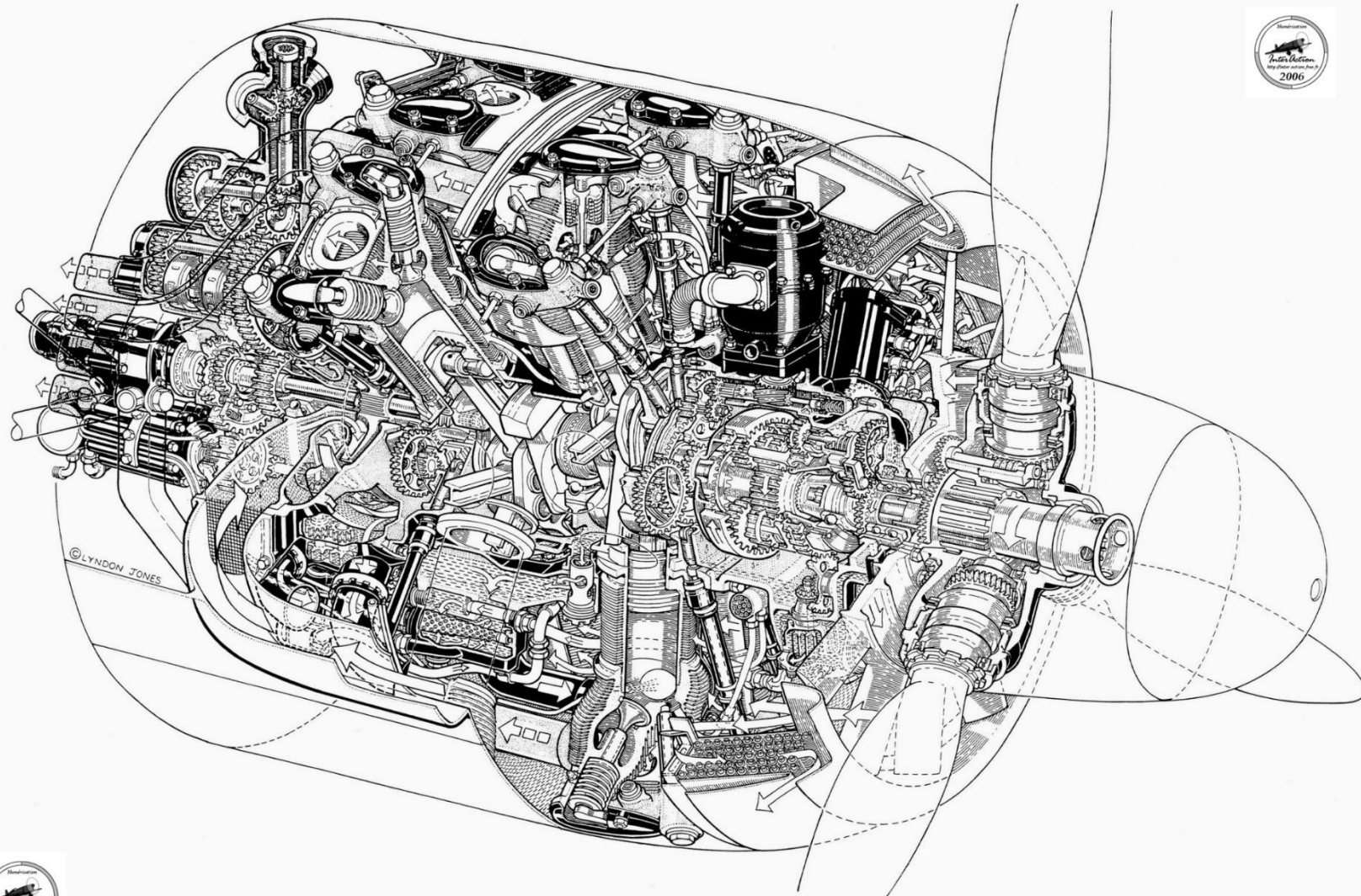

BMW 801D



BMW 801D-2 ENGINE

The lubrication system is integrated with the engine and is not included in the airframe design, with the exception of the pressure and oil temperature indicators. The radiator and the 58-liter oil tank (effective capacity - 55 liters) are ring-shaped and are located in the front of the engine under the armored casing.

All elements are connected to the oil filter through a pipe system. The oil system allows for the filling of hot oil or gasoline-diluted oil, which facilitates cold engine starting. The forced oil circulation is facilitated by the oil pump, while the oil temperature is automatically controlled by a thermostat.

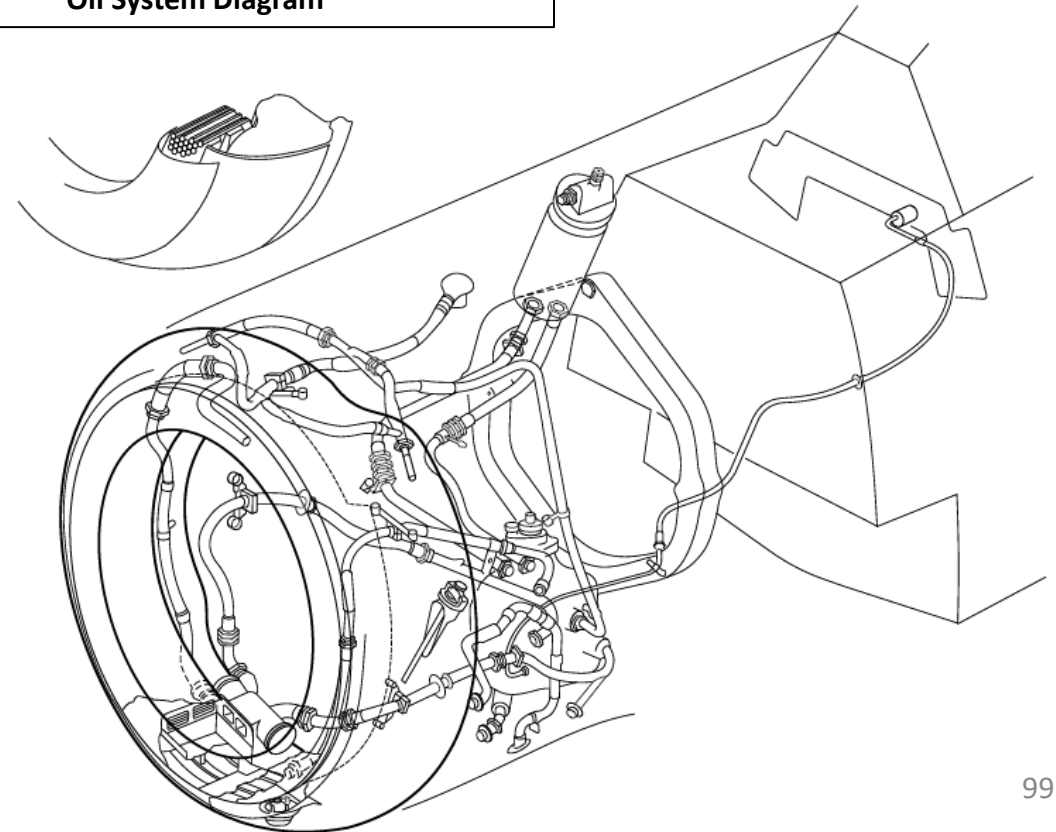
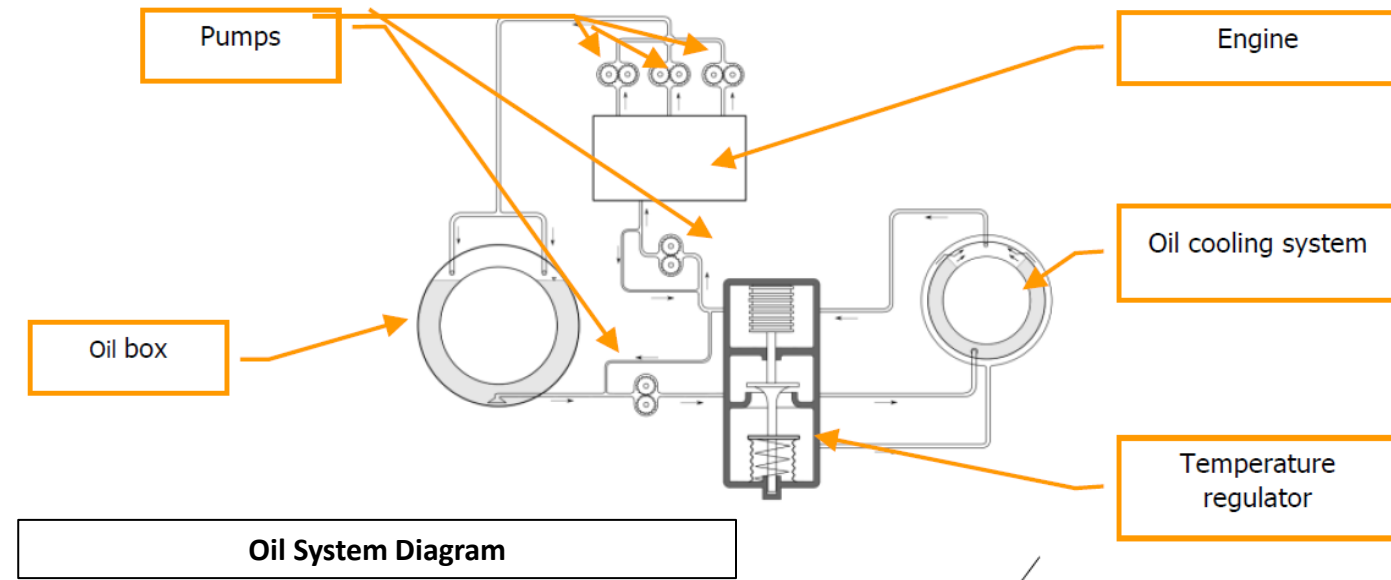

ENGINE INDICATIONS

Here is an overview of the various engine indications you have to monitor:

- **Engine Tachometer (x100 RPM):** Controlled by the throttle. Indicates engine speed turning the constant speed propeller.
- **Supercharger Pressure Gauge (ATA):** Similar to a Boost or Manifold Pressure indicator, supercharger pressure indicates the ratio between the absolute pressure after the supercharger and the atmospheric pressure in atmospheres (ATA). Values greater than 1 ATA indicate a pressure higher than atmospheric pressure, while values below 1 ATA indicate a pressure below atmospheric pressure. In ISA (standard) conditions, 1 ATA at sea level is roughly +0 Boost, 14.7 psi, 760 mm Hg, 29.92 in Hg, 1013.25 mBar, or 101.325 kPa.
- **Oil Temperature (deg C):** indicates the oil temperature in the engine lubrication system.
- **Oil Pressure Indicator (kg/cm²):** indicates the oil pressure of the engine lubrication system.
- **Engine Fuel Pressure Indicator (kg/cm²):** indicates the fuel pressure of the fuel pump system.
- **Propeller Pitch Indicator:** displays the position of the propeller blades. The hands of the device are like the hands of a clock: the 6:00 position corresponds to 100% (fine) pitch, and 12:30 - 0% (coarse) pitch.
- **Radiator Flaps Position Indicator:** displays the position of the radiator flaps. "Zu" means "Closed", "Auf" means "Open".

Engine Fuel Pressure Indicator (kg/cm²)

Engine Oil Pressure Indicator (kg/cm²)

Engine Oil Temperature Indicator (deg C)

Radiator Flaps Position Indicator

- Up: Zu (Closed)
- Down: Auf (Open)

Supercharger Pressure Gauge (ATA)

Similar to Boost or Manifold Pressure

Engine Tachometer (RPM/Umin x100)

Propeller Pitch Indicator

- 6:00 position: 100 % (Fine) Pitch
- 12:30 position: 0 % (Coarse) Pitch

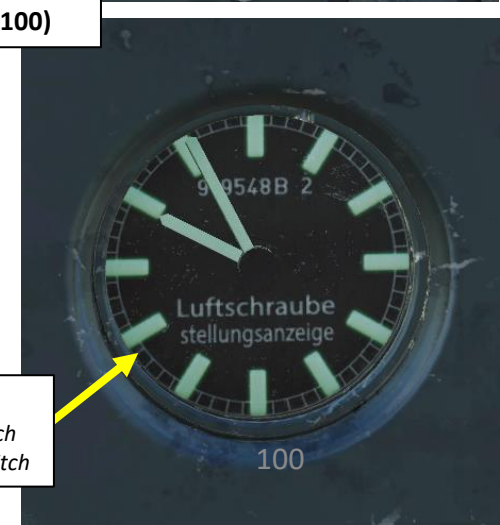

ENGINE CONTROLS

The main engine controls are:

- **Throttle:** Controls supercharger pressure (manifold pressure)
- **Propeller Governor Automation Switch and Propeller Pitch Manual Rocker Switch (*Drehzahl*):** Allows manual operation of propeller pitch.

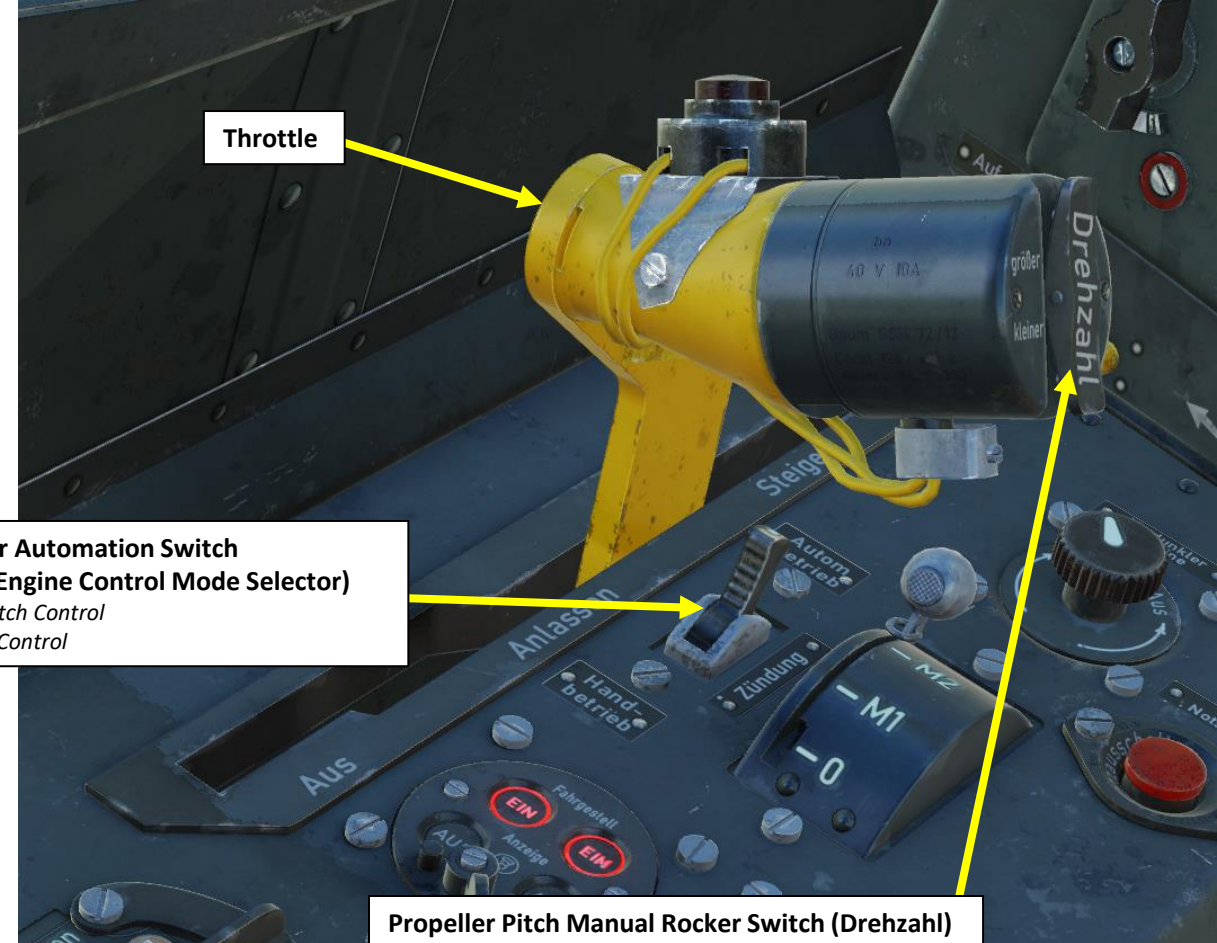

Throttle

**Propeller Governor Automation Switch
(Kommandogerät Engine Control Mode Selector)**

- *Fwd:* Automatic Pitch Control
- *Aft:* Manual Pitch Control

Propeller Pitch Manual Rocker Switch (*Drehzahl*)

- *Größer* = *Finer* = *Increases RPM*
- *Kleiner* = *Coarser* = *Decreases RPM*

ENGINE CONTROLS

The main engine controls are:

- **Radiator Flaps Control Lever:** Controls engine radiator, allowing to cool the engine.

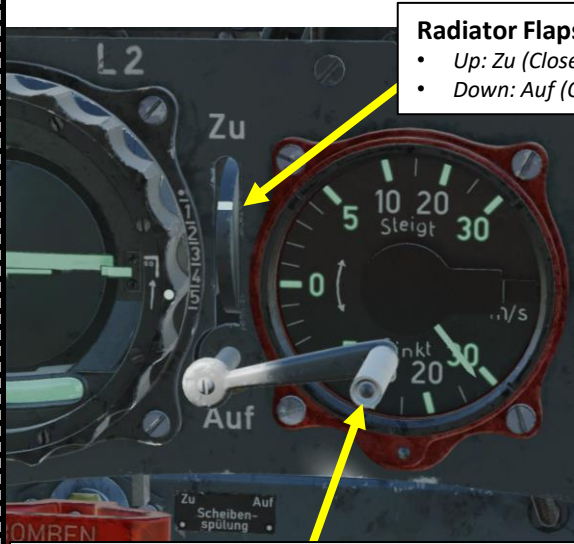

Radiator Flaps Position Indicator

- Up: Zu (Closed)
- Down: Auf (Open)

Radiator Flaps Control Lever

- Rotate clockwise to Open, counter-clockwise to Close

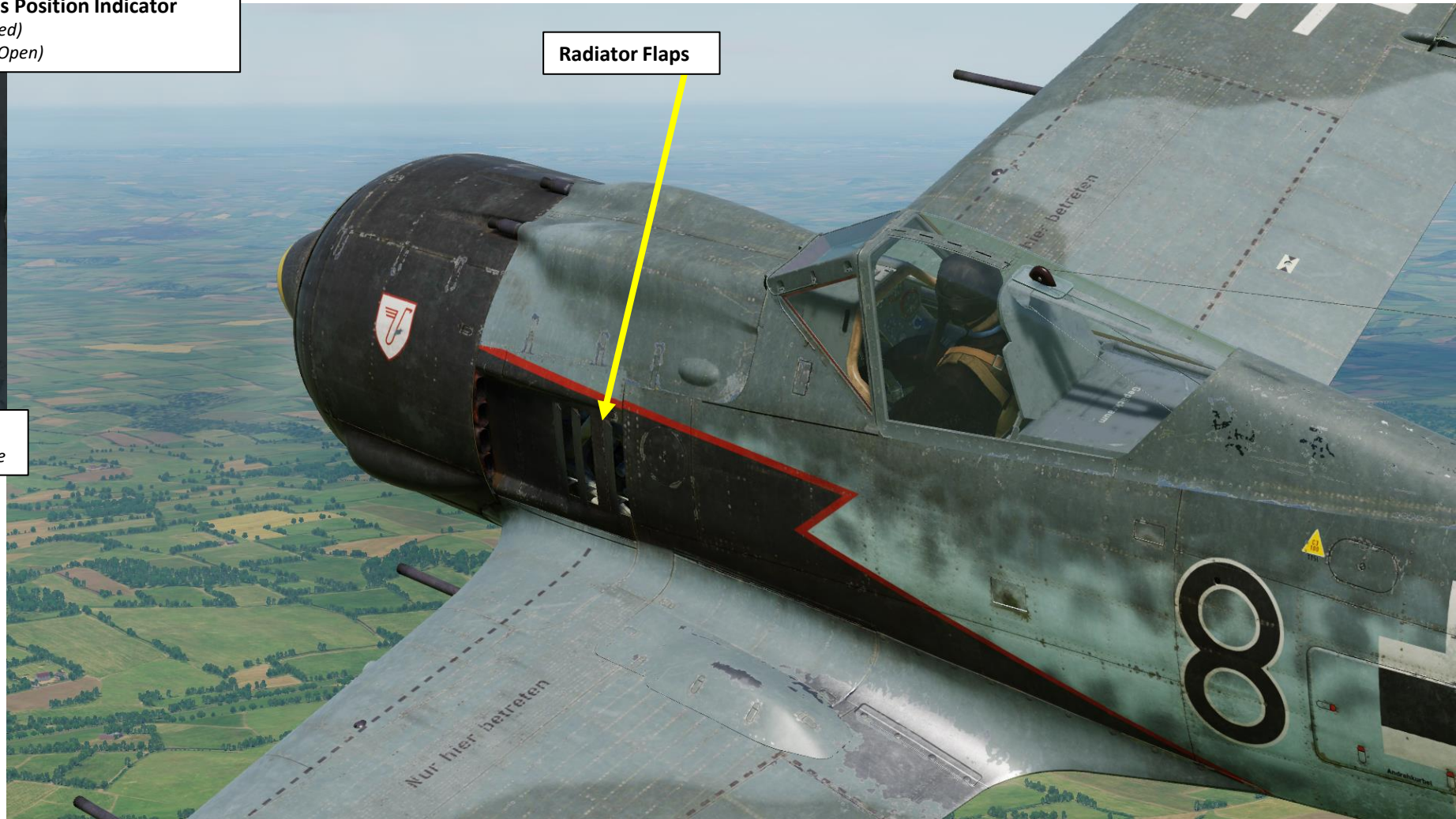

ENGINE OPERATION & LIMITS

Engine Power Settings:

- TAKEOFF: 2700 RPM
- LANDING: 1000 RPM
- NORMAL OPERATION: 2300 RPM

General Rule for Oil Temperature:

When oil temperature is above 110 deg C, make sure your Radiator Flaps are Open or you risk overheating. When oil temperature is below 110, close it to prevent overcooling.

Engine Limits:

- Oil Temperature: Min 110 deg C – Max 130 deg C
- Oil Pressure: Min 3 kg/cm² – Max 13 kg/cm²
- Fuel Pressure: Min 1.3 kg/cm² – Max 1.7 kg/cm²

If engine overheats, you can:

1. Enter a dive to increase airspeed and airflow to the engine intake.
2. Reduce throttle
3. Decrease rate of climb
4. Set radiator flaps to the Maximal "Auf (Open)" position.

CHECK YOUR ENGINE TEMPERATURES EVERY 30 SECONDS OR SO. IT WILL SAVE YOUR LIFE.

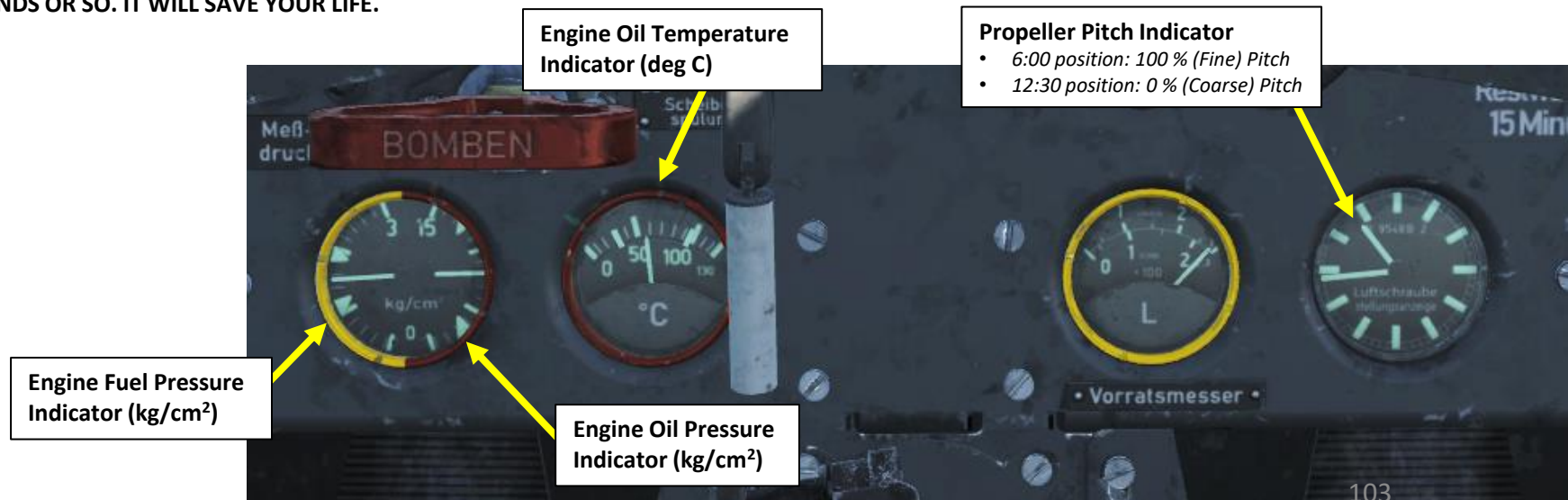
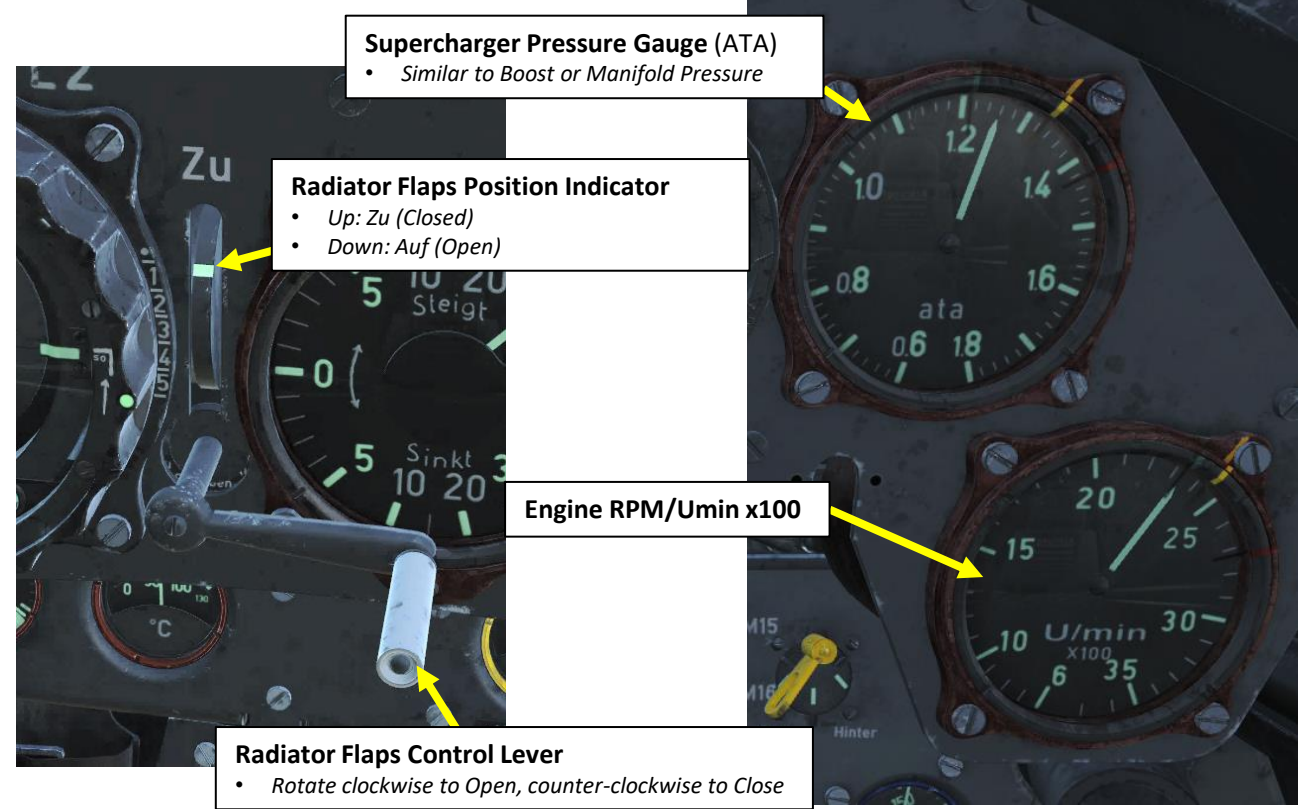

ENGINE OPERATION & LIMITS**POWER SETTINGS (SUPERCHARGER IN FIRST STAGE, BELOW 3300 M)**

Throttle Position (deg)	Power Output	RPM	Manifold Pressure (ATA)	Permissible Time	Altitude (m)
84-90	Takeoff & Emergency Power	2700	1.4	3 min	600
71	Combat & Climb Power	2400	1.3	30 min	700
66	Max Continuous Power	2300	1.2	Constant	1200
54	Max Economy Power	2100	1.1	Constant	1800

POWER SETTINGS (SUPERCHARGER IN SECOND STAGE, ABOVE 3300 M)

Throttle Position (deg)	Power Output	RPM	Manifold Pressure (ATA)	Permissible Time	Altitude (m)
84-90	Takeoff & Emergency Power	2700	1.4	3 min	5700
71	Combat & Climb Power	2400	1.3	30 min	5300
66	Max Continuous Power	2300	1.2	Constant	5500
54	Max Economy Power	2100	1.1	Constant	5400

KOMMANDOGERÄT ENGINE CONTROL UNIT

The *Kommandogerät* a hydromechanical multifunction integrator that dramatically simplifies engine control. While in most other contemporary aircraft the pilot had to constantly operate a slew of levers to manage throttle level, propeller pitch, fuel mixture, and supercharger stages, the *Kommandogerät* takes the majority of the workload away.

The pilot simply has to move the throttle lever to set the desired manifold pressure. The *Kommandogerät* takes care of the rest, setting all other parameters to allow the engine to properly operate at the desired manifold pressure, given the current flight conditions. The gauge used to monitor desired supercharger pressure is the supercharger pressure gauge to the right of the front dashboard labeled "ATA". If the *Kommandogerät* somehow fails, you can use a manual propeller pitch control.

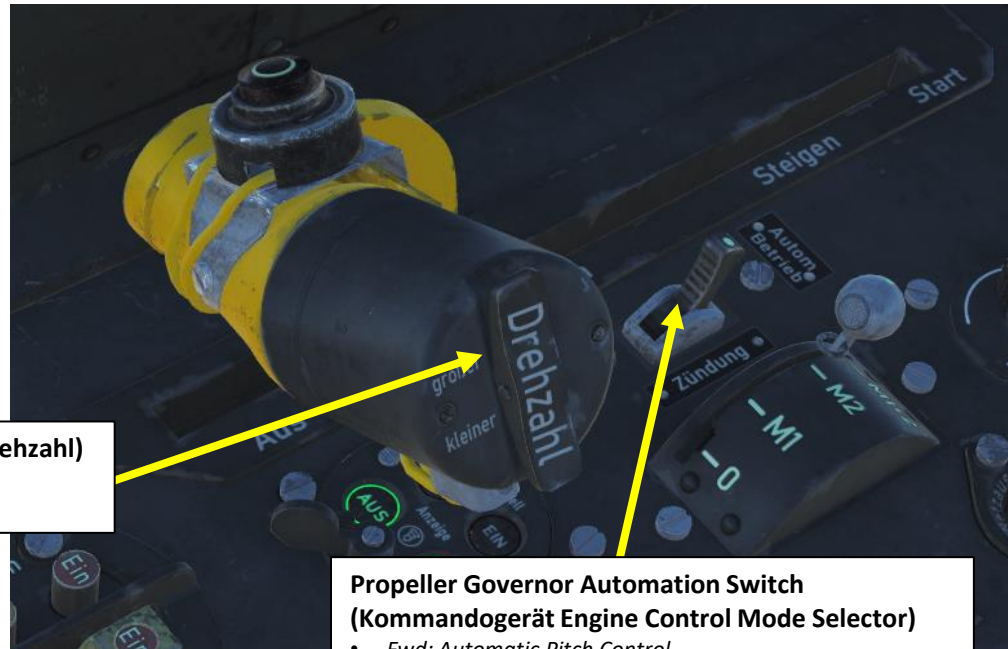

Propeller Pitch Manual Rocker Switch (Drehzahl)

- *Größer = Finer = Increases RPM*
- *Kleiner = Coarser = Decreases RPM*

Propeller Governor Automation Switch (Kommandogerät Engine Control Mode Selector)

- *Fwd: Automatic Pitch Control*
- *Aft: Manual Pitch Control*



Propeller Pitch Indicator

- *6:00 position: 100 % (Fine) Pitch*
- *12:30 position: 0 % (Coarse) Pitch*

SUPERCHARGER BASICS

A **supercharger is an engine-driven air pump or compressor that provides compressed air to the engine to provide additional pressure to the induction air so the engine can produce additional power.** It increases manifold pressure and forces the fuel/air mixture into the cylinders. The higher the manifold pressure, the more dense the fuel/air mixture, and the more power an engine can produce.

With a normally aspirated engine, it is not possible to have manifold pressure higher than the existing atmospheric pressure. A supercharger is capable of boosting manifold pressure above 1.0 ATA (30 in Hg). For example, at 2500 meters (8000 ft) a typical engine may be able to produce 75 percent of the power it could produce at mean sea level (MSL) because **the air is less dense at the higher altitude.** The supercharger compresses the air to a higher density allowing a supercharged engine to produce the same manifold pressure at higher altitudes as it could produce at sea level.

Thus, an engine at 8,000 feet MSL could still produce 0.85 ATA of manifold pressure whereas without a supercharger it could produce only 0.75 ATA. Superchargers are especially valuable at high altitudes (such as 18,000 feet / 5500 m) where the air density is 50 percent that of sea level. The use of a supercharger in many cases will supply air to the engine at the same density it did at sea level. With a normally aspirated engine, it is not possible to have manifold pressure higher than the existing atmospheric pressure.

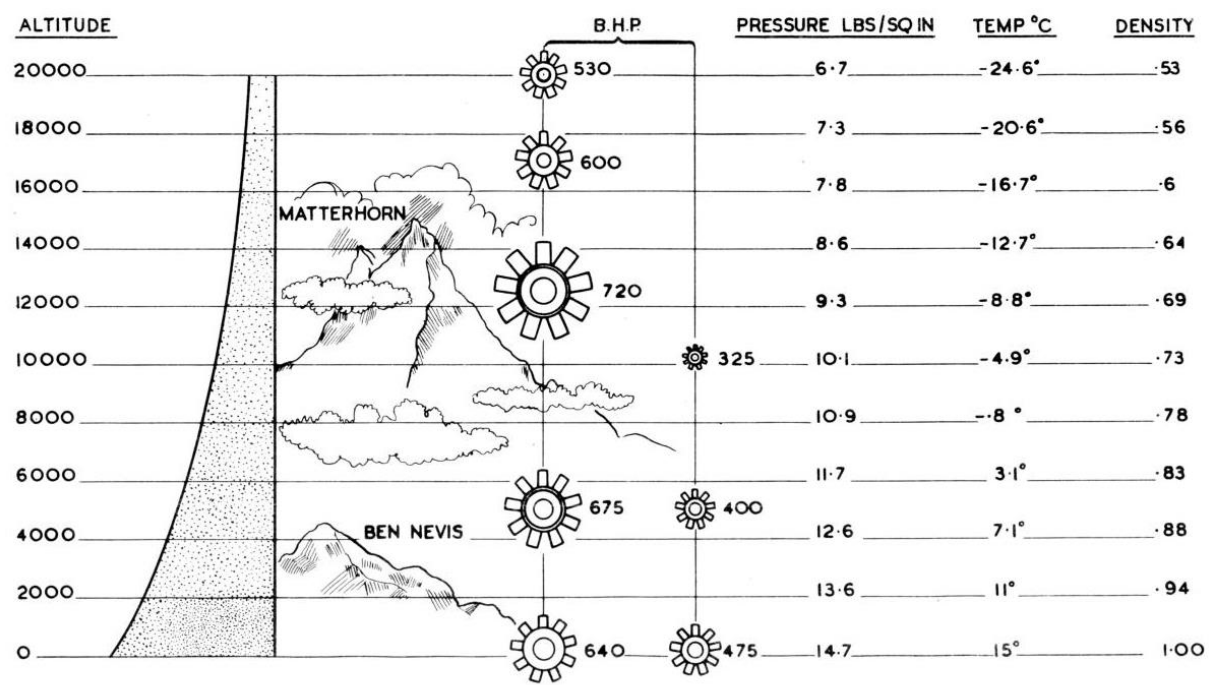
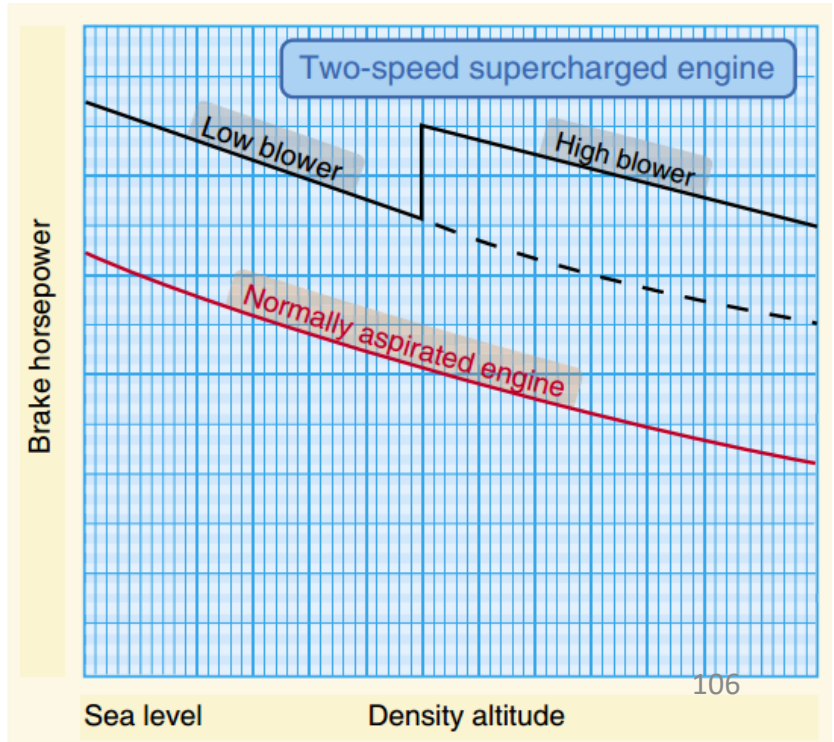

DIAGRAM SHOWING ATMOSPHERIC AND POWER VARIATIONS



SUPERCHARGER OPERATION

The supercharger installed on the BMW 801D-2 engine comes equipped with a two-speed supercharger, a reduction gear, and a 12-blade cooling fan. The fan located in front of the engine supplies the air which enters the filtered air intakes through two channels on both sides of the fuselage fairing. In the 1930's-1940's, the first few aircraft that had a two-speed supercharger had a manual control that had to be set once the aircraft was high enough (air density was low enough to see a noticeable difference once the supercharger is shifted into second gear). In our case, the **supercharger shifts gear automatically** (managed by the Kommandogerät Control Unit) once a threshold altitude is reached. There is no indicator to see in which gear the aircraft is. In practice, you will notice the manifold pressure gauge (ATA) will suddenly increase once the supercharger shifts into high gear.

At an altitude of approximately 3300 +/- 200 meters, the supercharger automatically switches supercharger speed from low to high. Try not to fly or frequently change your altitude within this threshold.

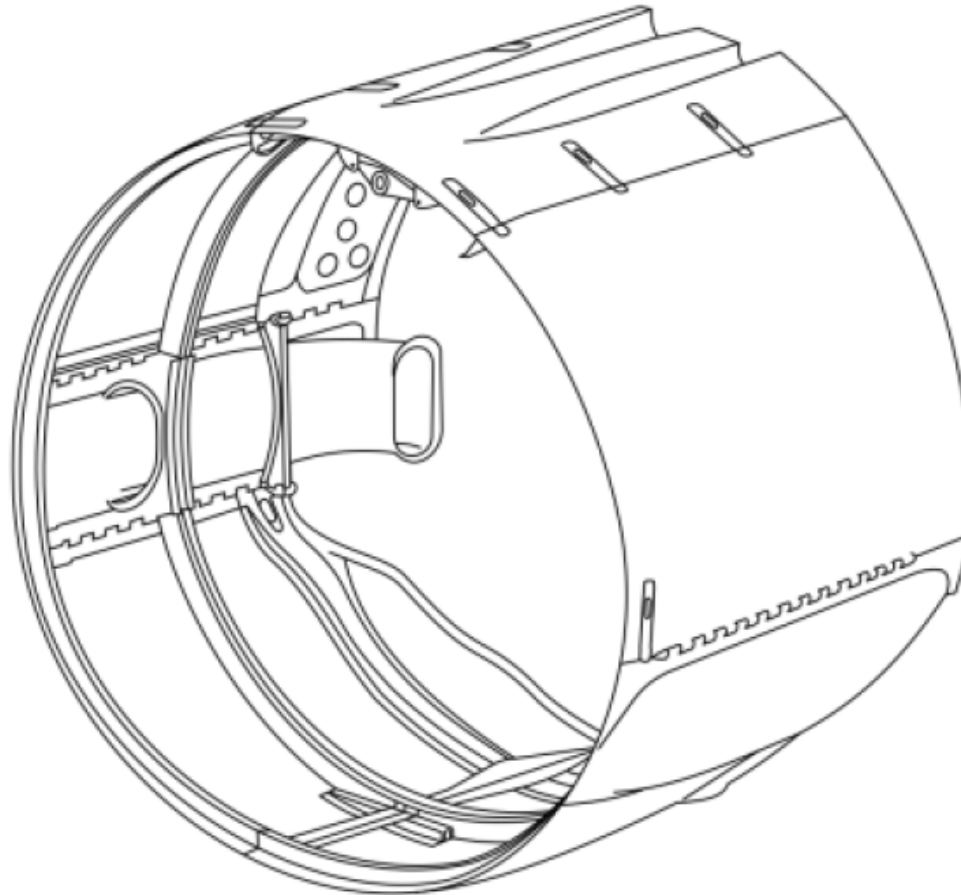

Engine cowling with internal air intake channels

FUEL TANKS

Fuel Capacity
Vorn/Front Tank Capacity: 232 L (172 kg)
Hinten/Rear Tank Capacity: 292 L (216 kg)
Total Capacity: 524 L (388 kg)

Note: A drop tank with a capacity of 300 liters can be installed under the fuselage on the ETC 501 rack

Hinten/Rear Fuel Tank

Vorn/Front Fuel Tank

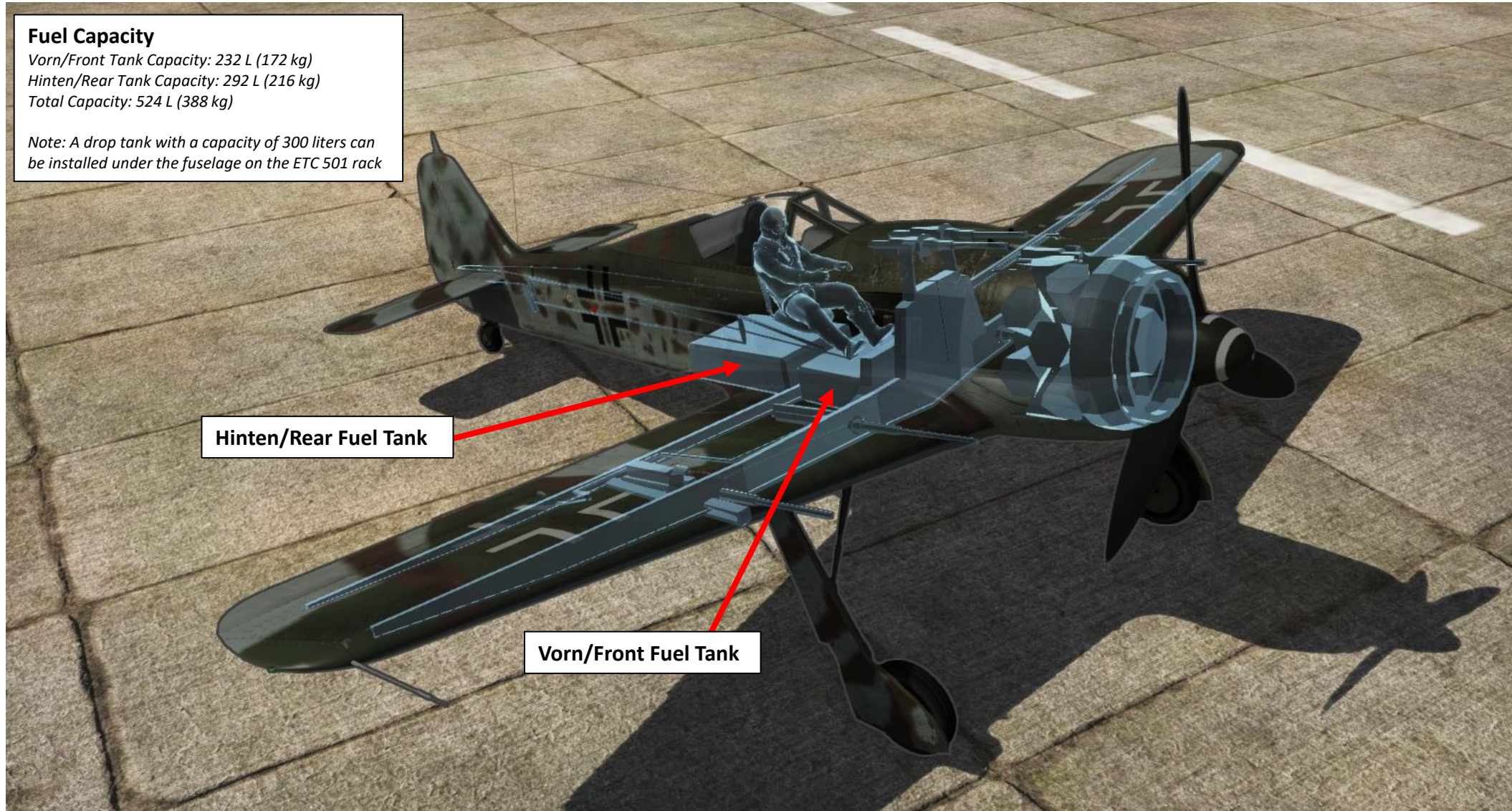

FUEL MANAGEMENT

Since If there are additional fuel tanks (auxiliary fuselage and/or external drop tank), the fuel from them enters the rear fuel tank via two lines. When the fuel level in the aft tank reaches exactly 240 liters, the restrictor valve opens up the auxiliary line. The additional tanks continue to feed the aft tank until they are fully depleted. The additional tanks are not equipped with any fuel gauge sensors, and so the only way to tell that they have been fully depleted is when the aft tank's fuel level begins to drop below 240 liters.

When flying with drop tanks, drop tank fuel should be used first (Set Fuel Tank Selector to “Vorderer Behälter zu” to close the forward tank and use fuel from the drop tank, which feeds into the rear tanks). When the fuel inside the drop tank is exhausted, the fuel tank selector lever is set to “Auf” and the external drop tank fuel pump should be turned off.

- E14 Forward Tank (vorderer Behälter) Fuel Pump Circuit Breaker
- E13 Rear Tank (Hintener Behälter) Fuel Pump Circuit Breaker
- E16 External Tank (Abwurfbehälter) Fuel Pump Circuit Breaker
- E96 Auxiliary Tank (Zus Behälter) Fuel Pump Circuit Breaker



Fuselage Stores (Drop Tanks or Bombs) Jettison Handle

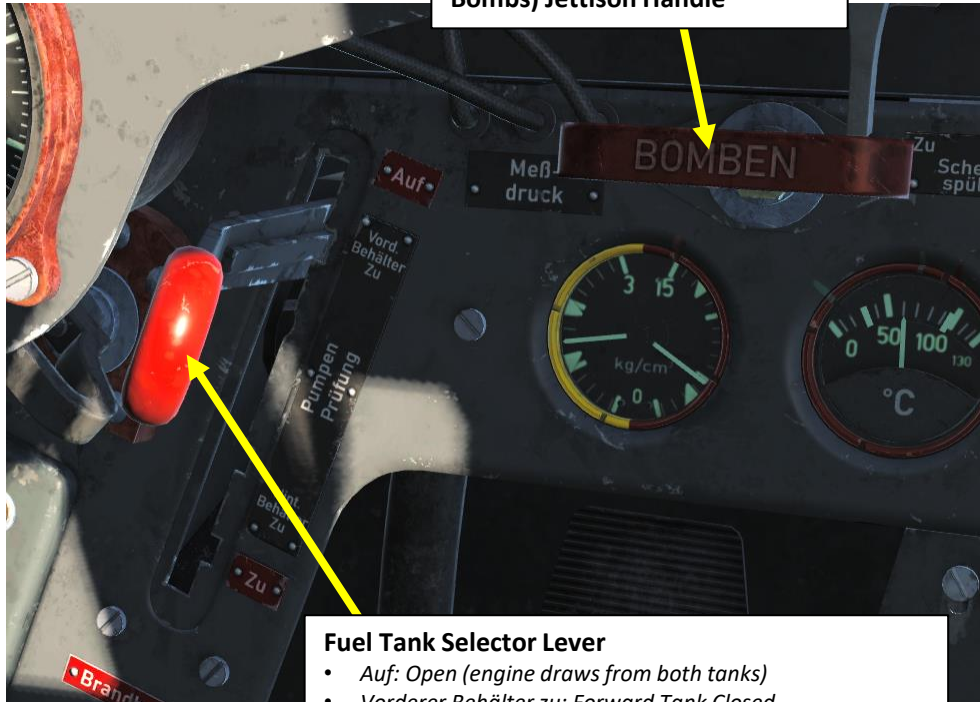

Fuel Gauge (x100 Liters)
 • Vorn/Front Tank Capacity: 232 L (172 kg)
 • Hinten/Rear Tank Capacity: 292 L (216 kg)
 Total Capacity: 524 L (388 kg)

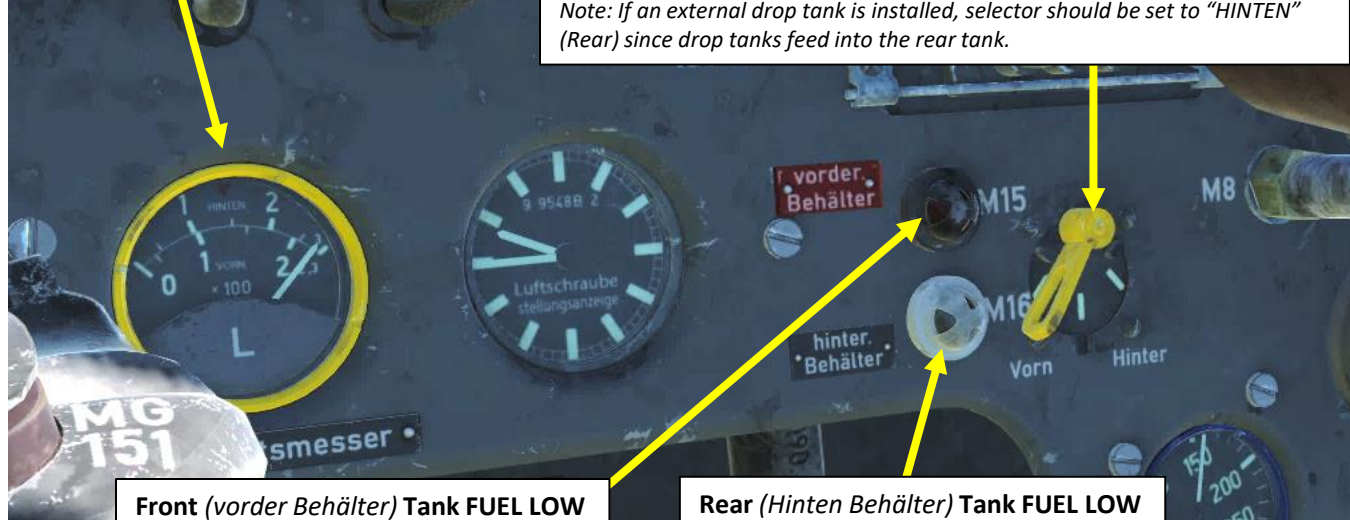

Fuel Gauge Indication Selector
 • Left: Vorn = Front
 • Middle: No Tank Selected
 • Right: Hinten = Rear
 Note: If an external drop tank is installed, selector should be set to “HINTEN” (Rear) since drop tanks feed into the rear tank.

Fuel Tank Selector Lever
 • Auf: Open (engine draws from both tanks)
 • Vorderer Behälter zu: Forward Tank Closed
 • Hintener Behälter zu: Rear Tank Closed
 • Zu: Closed (both fuel lines to booster pump are closed)

Front (vorder Behälter) Tank FUEL LOW warning light
 • Illuminates when below 80 Liters

Rear (Hinten Behälter) Tank FUEL LOW warning light
 • Illuminates when below 10 Liters

FUEL MANAGEMENT

Engine-driven pumps feed the fuel into the engine at a normal pressure of 1 to 2 kg/cm². There is also an electrical booster pump in each of the two tanks that prevents vapor lock at altitude, provides improved fuel supply and can serve as a back-up in case of main pump failure. A fuel tank with a capacity of 115 liters or an 85-liter tank containing the GM-1 mixture may also be installed behind the eighth bulkhead.

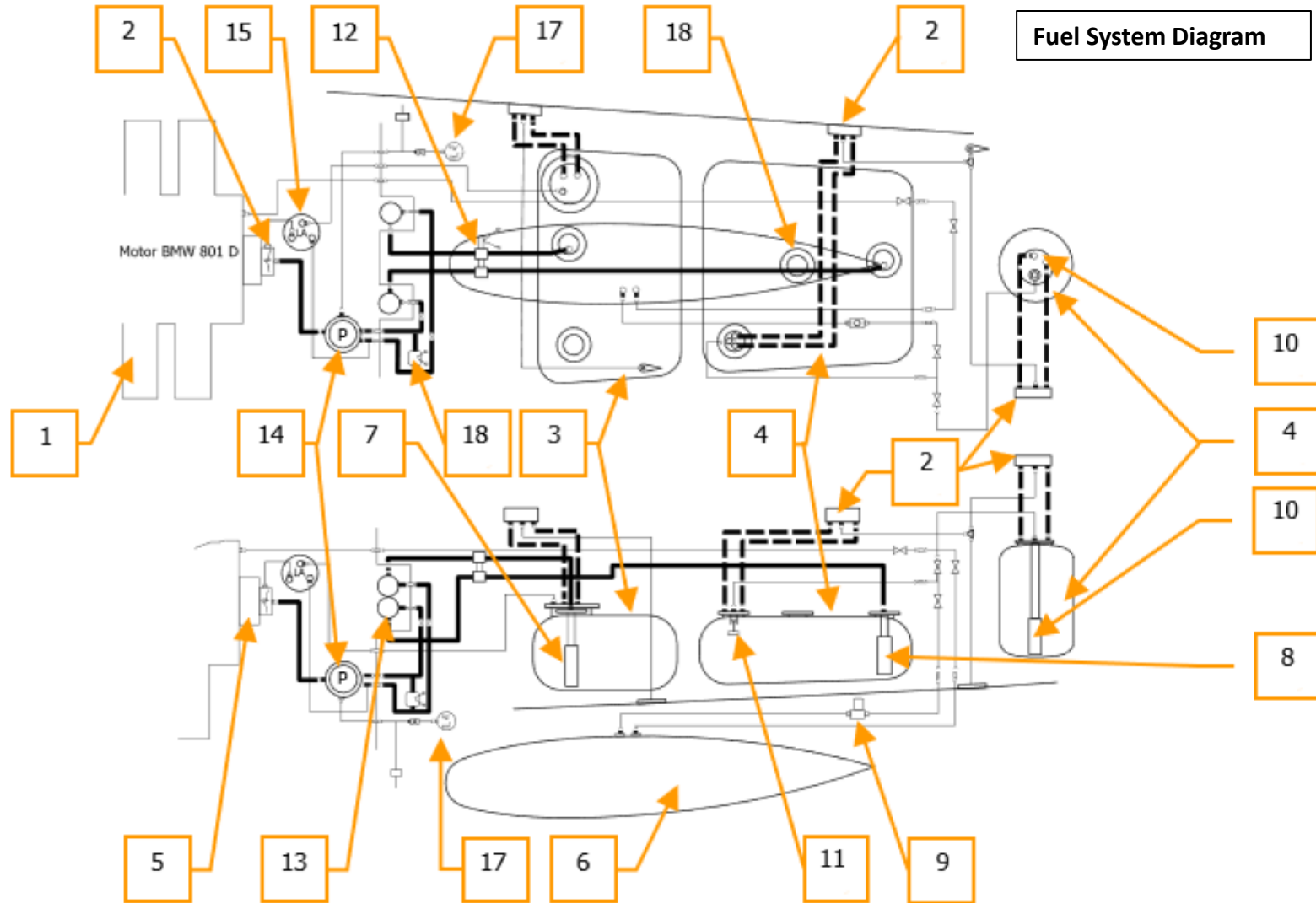

Fuel System Diagram

1. BMW 801D-2 engine
2. Filler necks
3. Forward tank (232 l)
4. Aft tank (292 l)
5. Auxiliary fuselage tank (115 l)
6. Auxiliary jettisonable tank
7. Forward tank feeder pump
8. Aft tank feeder pump
9. Auxiliary jettisonable tank feeder pump
10. Auxiliary fuselage tank feeder pump
11. Shutter valve (shuts at 240 l)
12. Fuel selector
13. Fuel filter
14. Booster pump
15. Vapor separator
16. Fuel pressure gauge
17. Fuel line shutoff valve
18. Primer fuel canister (3 l)

FUEL DROP TANK OPERATION

1. Since the drop tank feeds into the rear fuel tank, set fuel tank selector lever to "VORDERER BEHÄLTER ZU" (FORWARD TANK CLOSED) and turn on the E96 Fuel Pump Circuit Breaker to consume fuel from the drop tank first.

E14 Forward Tank (vorderer Behälter) Fuel Pump Circuit Breaker
 E13 Rear Tank (Hintener Behälter) Fuel Pump Circuit Breaker
 E16 External Tank (Abwurfbehälter) Fuel Pump Circuit Breaker
 E96 Auxiliary Tank (Zus Behälter) Fuel Pump Circuit Breaker

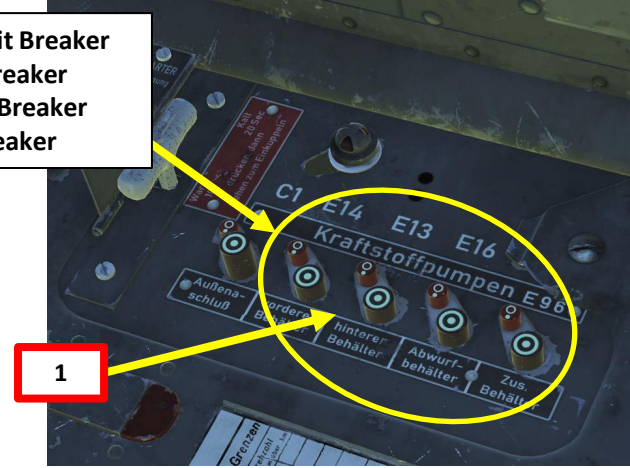

FUEL DROP TANK OPERATION

- When ready to jettison drop tank, make sure that your fuel tank selector is set to “AUF” (OPEN) and turn off the E96 Fuel Pump Circuit Breaker.
- To jettison fuel drop tank, pull the “BOMBEN” (BOMB/DROP TANK JETTISON) handle.

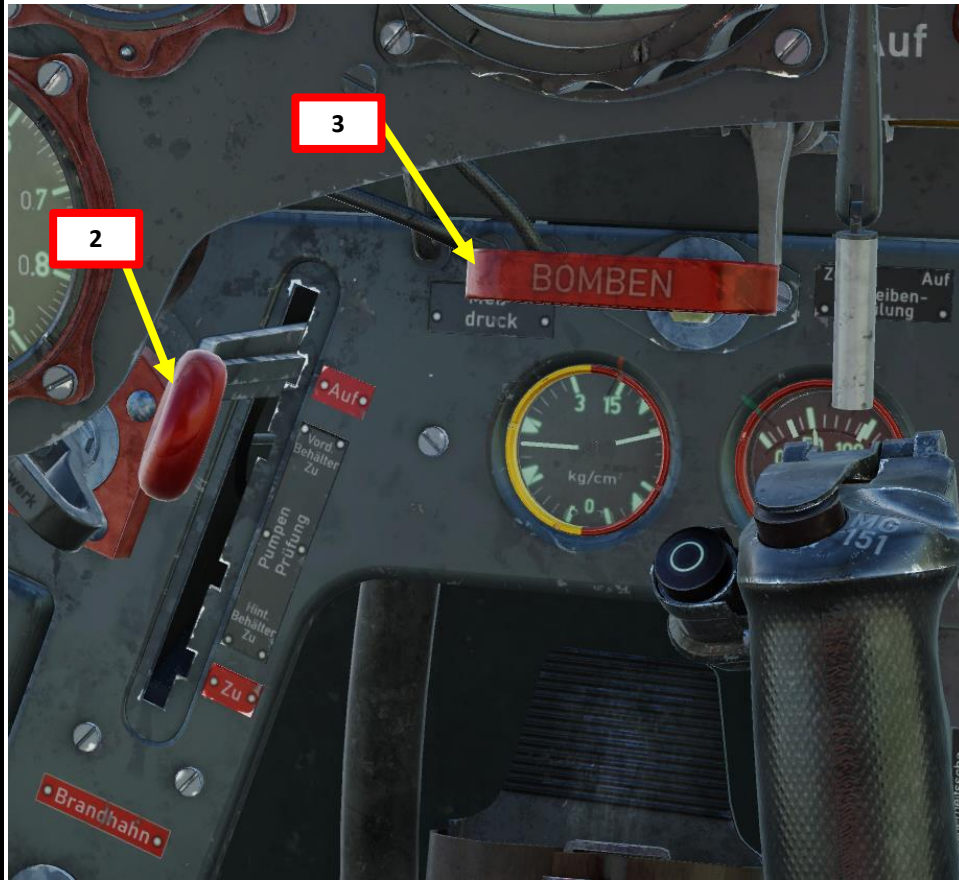
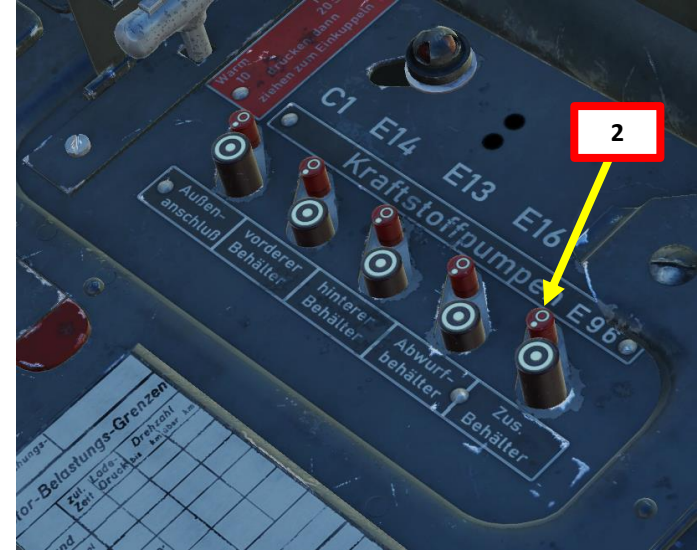

AIRSPD LIMITS

Here is an overview of some of the important airspeeds to remember.

- Maximum Flaps Extension Speed: 250 km/h
- Maximum Landing Gear Extension Speed: 250 km/h
- Optimal Climb Speed: 280-290 km/h
- Do-Not-Exceed Airspeed (V_{NE}): See Airspeed Indicator



Airspeed Indicator (km/h)

Not to Exceed diving speeds are handwritten on the airspeed gauge

Airspeed @ Altitude

- 500 km/h @ 9 km
- 600 km/h @ 7 km
- 700 km/h @ 5 km
- 800 km/h @ 3 km
- 850 km/h @ 2 km



ARMAMENT OVERVIEW

- 4 x Mauser MG 151 20 mm Cannons (250 rounds per cannon for inner wing guns, 125 rounds per cannon for outer wing guns)
- 2 x Rheinmetall-Borsig MG 131 13 mm Machineguns (475 rounds per gun)
- 4 x SC-50 kg bomb
- 1 x SC-250 kg bomb
- 1 x SC-500 kg bomb
- 2 x BR 21 Werfer-Granate 21-cm anti-air Rockets

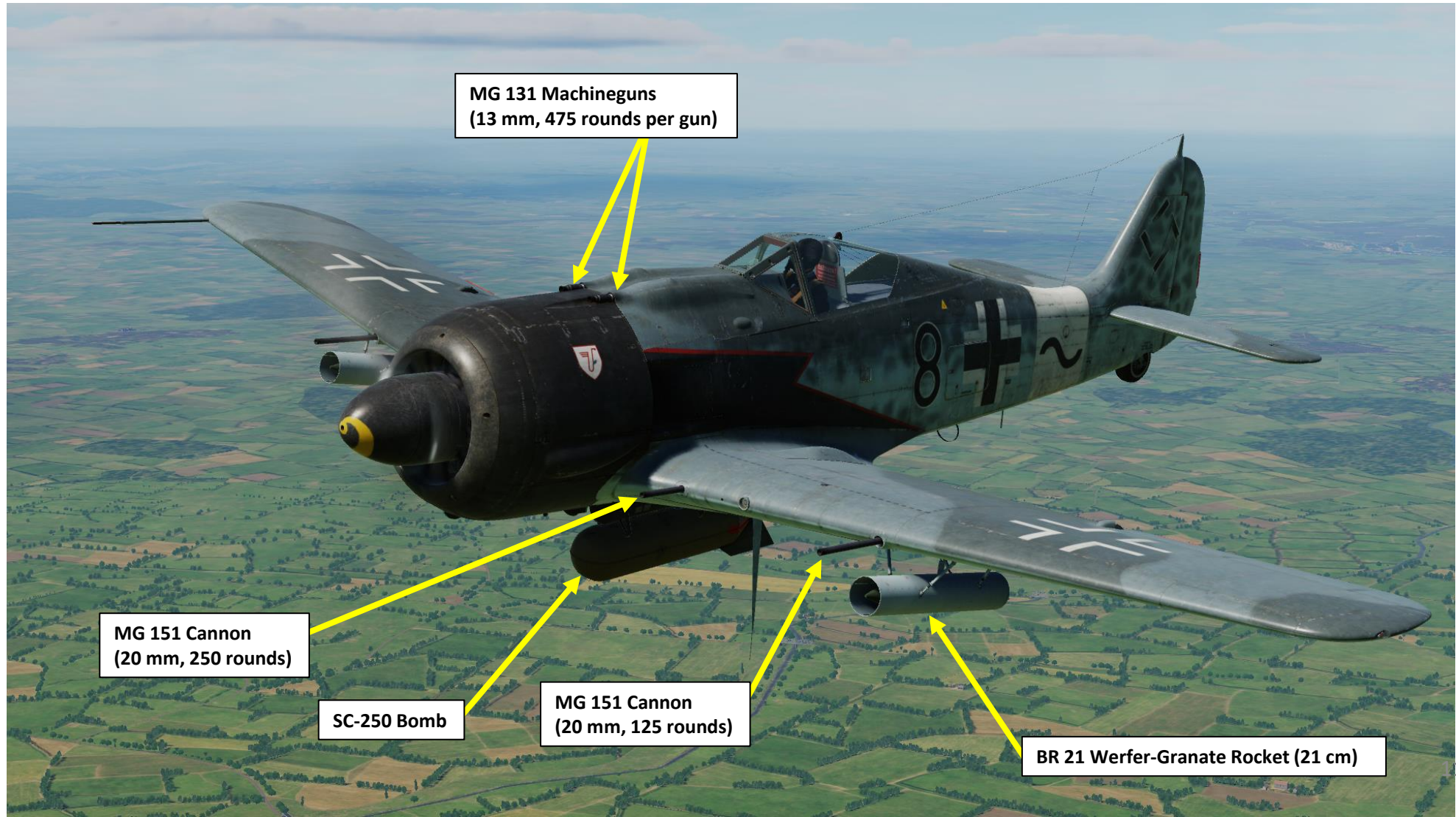

MG 131 Machineguns
(13 mm, 475 rounds per gun)

MG 151 Cannon
(20 mm, 250 rounds)

SC-250 Bomb

MG 151 Cannon
(20 mm, 125 rounds)

BR 21 Werfer-Granate Rocket (21 cm)

REVI-16B (REFLEXVISIER) GUNSIGHT

For weapon targeting, the Fw 190 A-8 came equipped with the standard Revi 16B gunsight that was installed on the vast majority of Luftwaffe combat aircraft.

The Revi 16B is a sight designed for use with both synchronized and unsynchronized aircraft weaponry and is equipped with both a built-in dimming rheostat for adjusting the crosshair brightness and a night filter.

Reflector sights work by projecting an image of the targeting reticle onto the reflector glass such that the reticle appears at infinity, providing a fixed aiming point relative to the weapon's line of fire. Alternatively, you can use the Mechanical Sight to aim.

When using the Revi 16B in combat, the pilot must independently make corrections for the target lead and distance, G-loads, and other parameters necessary for accurate fire.

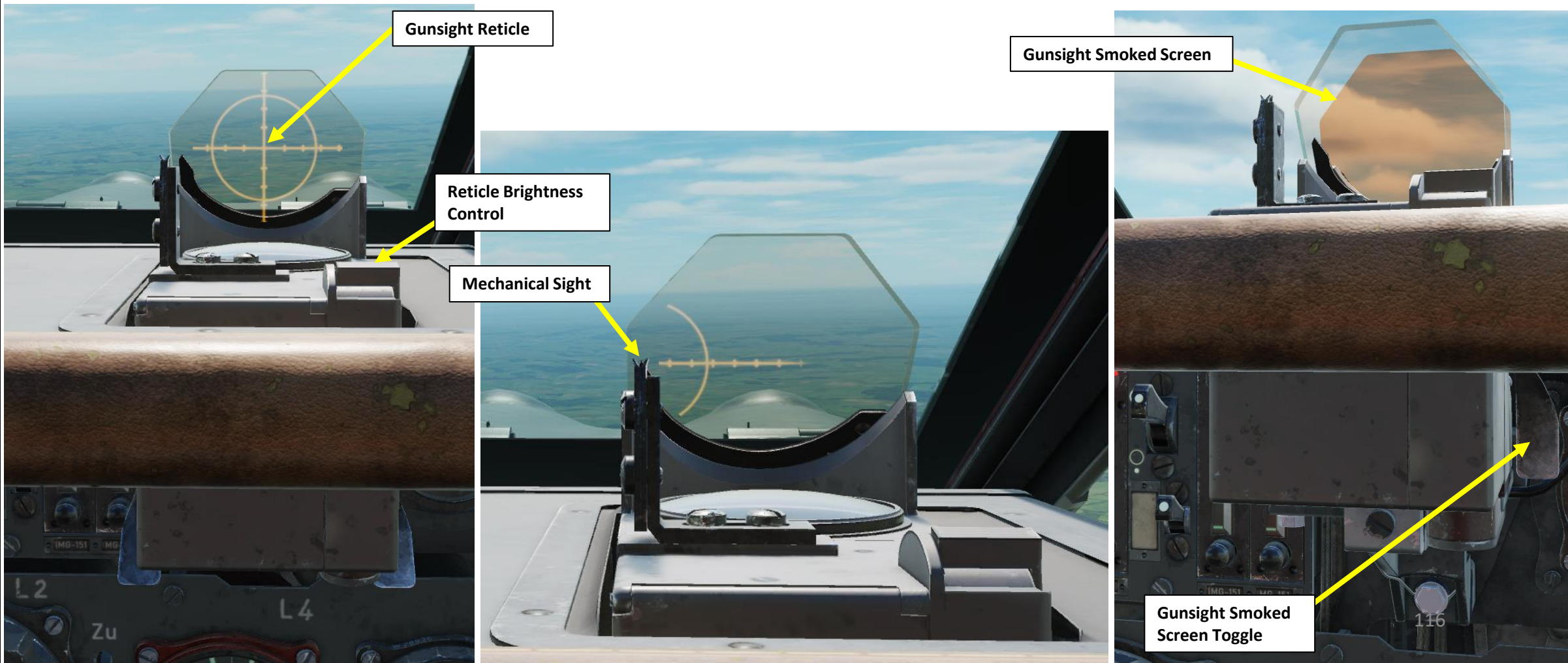

REVI-16B (REFLEXVISIER) GUNSIGHT

The ring of the REVI-16B gunsight is 100 mils in diameter. Each tick mark along the horizontal and vertical axis represents 18 mils. One mil (or “milliradian”, an angle unit) represents approximately 1 m of length, width or height of an object. Here is an excellent video by “The Air Combat Tutorial Library” on gunsight employment: <https://youtu.be/MaWB3uAkycs>

A good rule of thumb to range a target is:

- Target Range (in meters) = Wingspan (in meters) x (number of times it fills the ring) x 10

As an example (see **purple** lines below): The Spitfire has a wingspan of 11 m. If its wingspan fits 2 times inside the ring, the range can be estimated as follows:

- Range = 11 m x 2 x 10 = 220 m

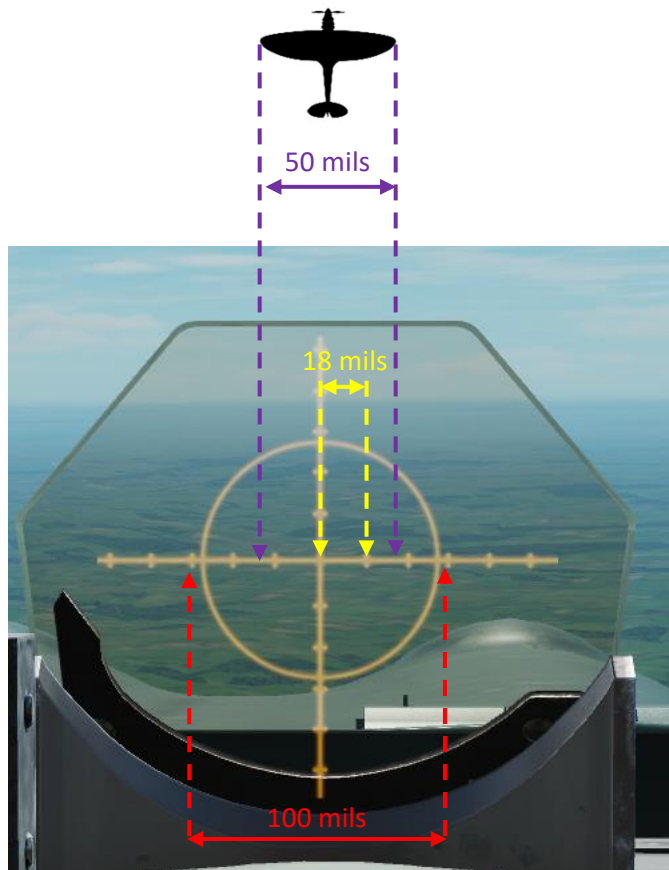

REVI C 12/D: ESTIMATING RANGE

Example with aircraft wingspan: 10 m

How much a fighter fills the ring tells you its distance:

1 diameter	1/2 diameter	1/3 diameter
<p>100 meters</p>	<p>200 meters</p>	<p>300 meters</p>

Source: The Air Combat Tutorial Library

WEAPON CONTROLS

B1 Button
Outer Wing MG 151 Cannon Button
• *RALT+SPACE binding*

Gun/Cannon Safety Cover
• *LSHIFT+SPACE binding*

B2 Button
Bomb/Rocket Release Button
• *RSHIFT+SPACE binding*

A Button
Inner Wing MG 151 Cannon & MG 131 Machinegun Button
• *Note: If the Cannon Safety Cover is ON, the MG 151/131 Trigger will only fire machineguns when pressed.*

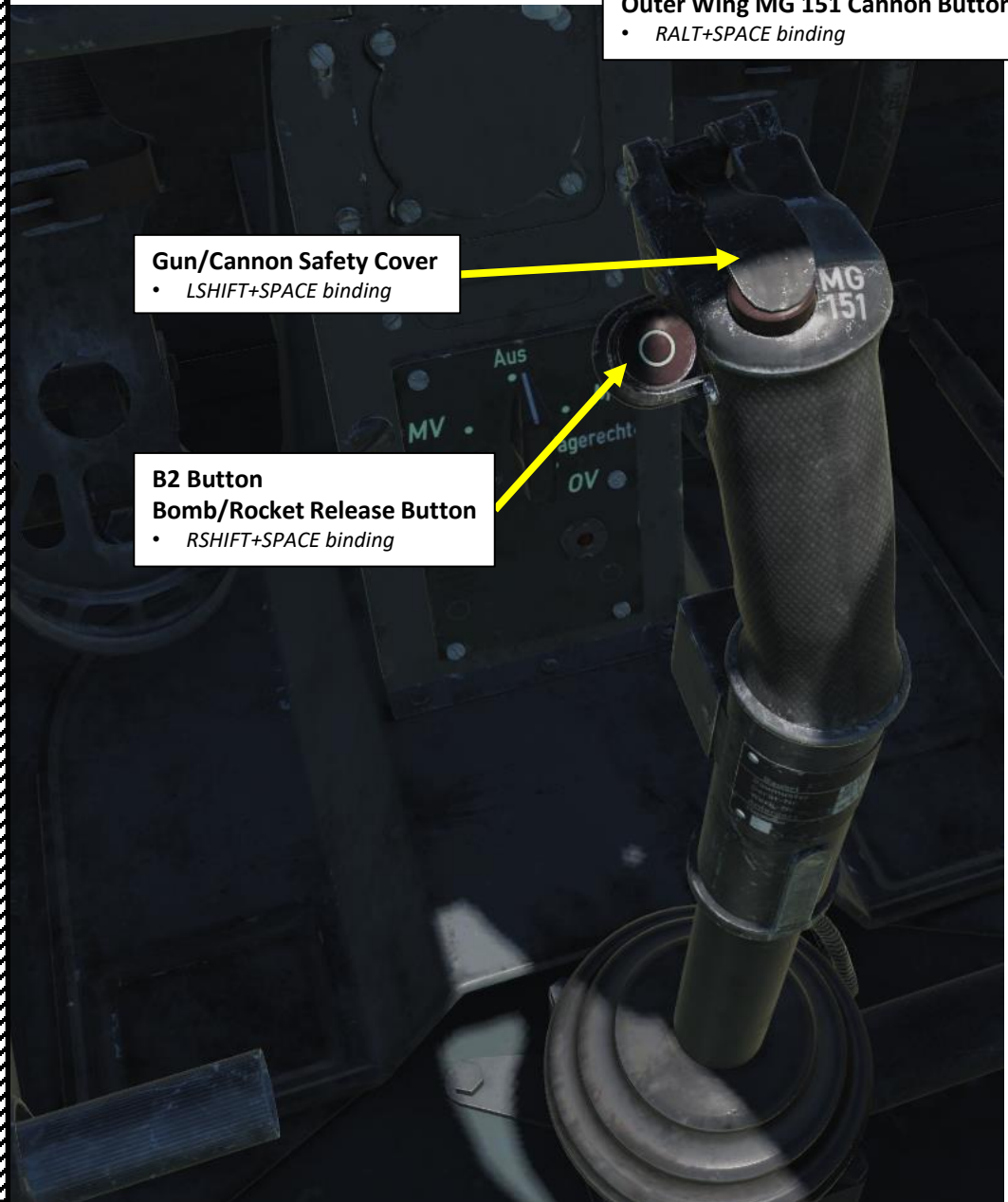

WEAPON CONTROLS

MG 151 Cannon Breechblock Status Signal Lamp

- Illuminated: Open
- Extinguished: Closed

Lamp flickering when firing the weapon means the breechblock mechanism operates properly. If lamp remains extinguished or illuminated when trigger is pressed, a weapon malfunction has occurred.

Master Arm Safety I Switch (Machineguns and Inner Wing Cannons)

- UP: ON / DOWN : OFF

MG 151 Cannon Ammunition Counter

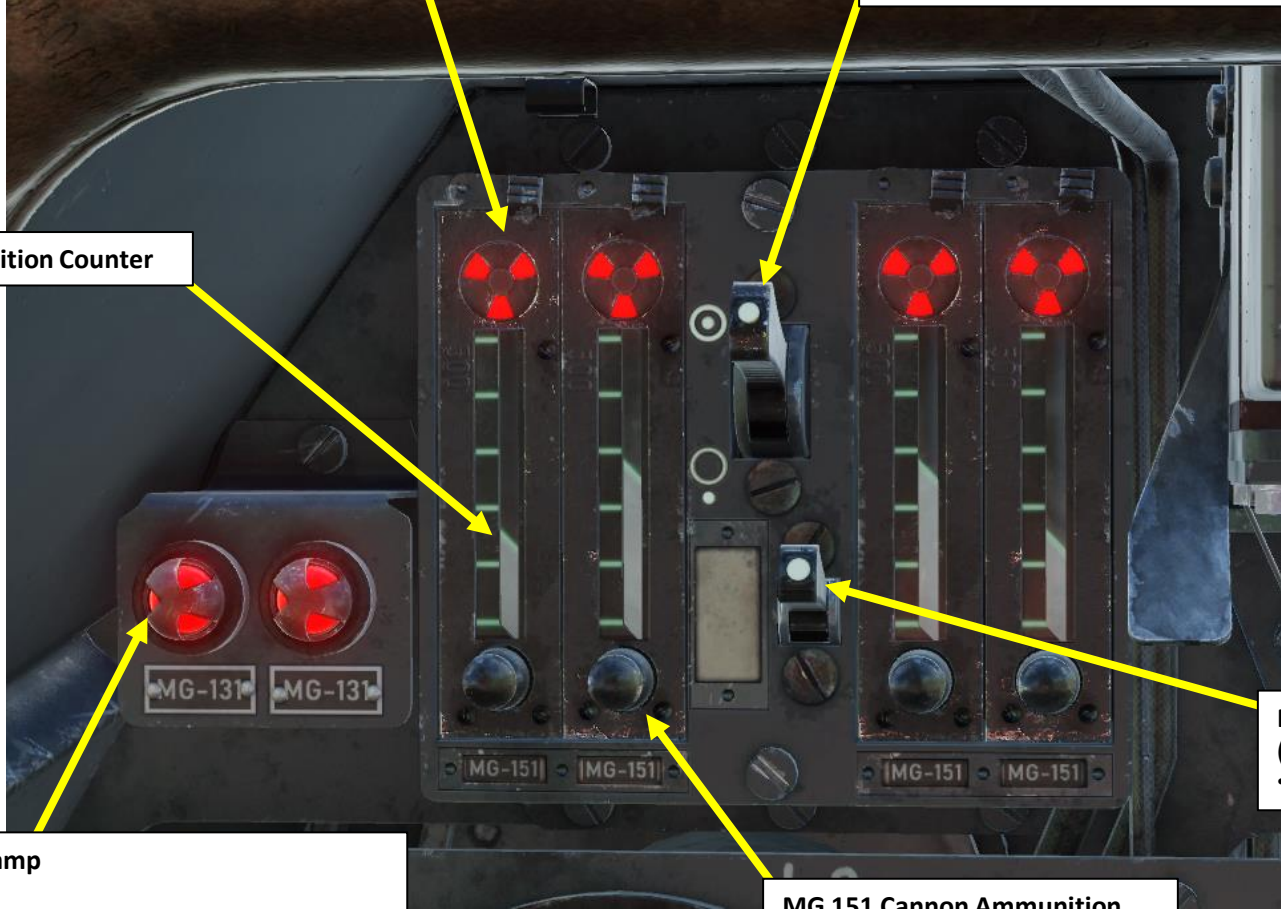

Master Arm Safety II Switch (Outer Wing Cannons)

- UP: ON / DOWN : OFF

MG 131 Machinegun Breechblock Status Signal Lamp

- Illuminated: Open
- Extinguished: Closed

Lamp flickering when firing the weapon means the breechblock mechanism operates properly. If lamp remains extinguished or illuminated when trigger is pressed, a weapon malfunction has occurred.

MG 151 Cannon Ammunition Counter Setting knob

WEAPON CONTROLS

Rocket Arming Switch (SICHERHEITSSCHA. GERÄT 21)

- Ein: Armed
- Aus: Disarmed

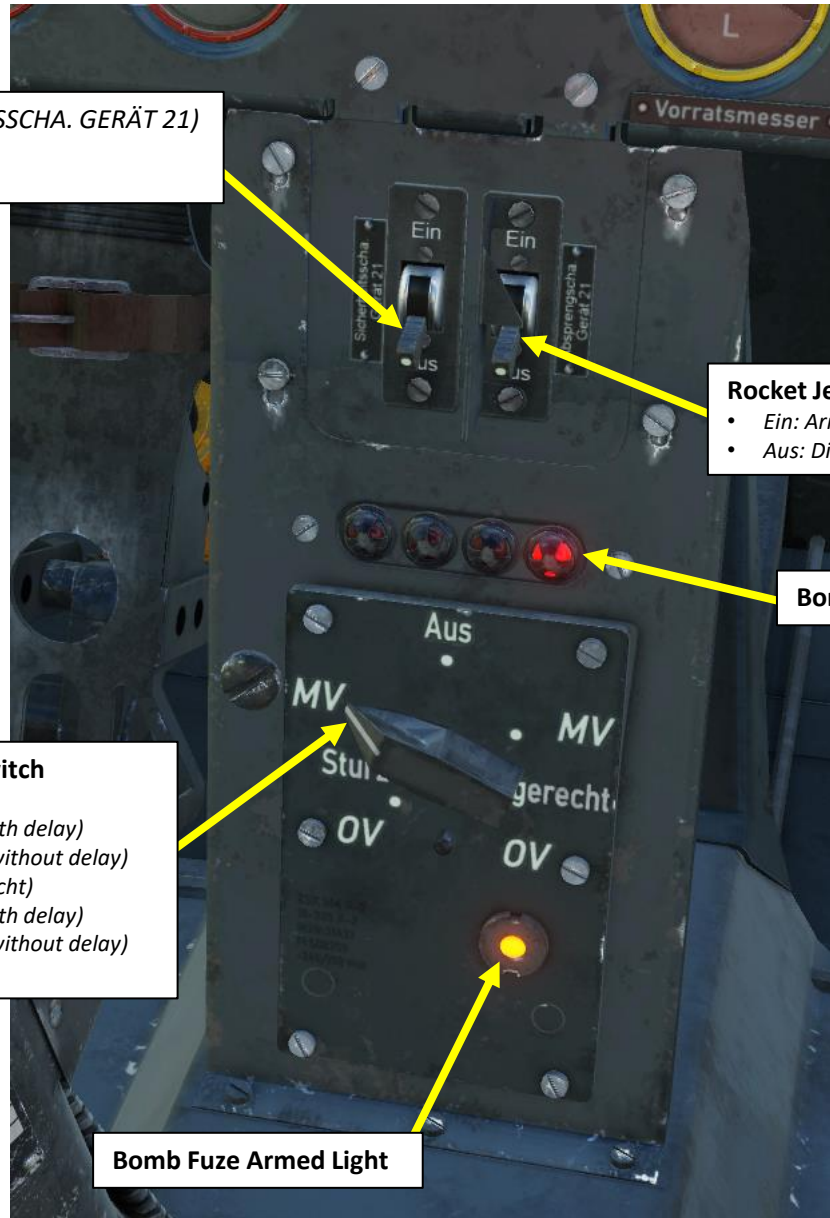

Rocket Jettison Switch (ABSPRENGSCHA. GERÄT 21)

- Ein: Armed
- Aus: Disarmed

Bomb Loaded Lights

Bomb Release Mode Selector Switch

- Left side: Dive Bombing (Sturz)
 - MV: Mit Verzögerung (with delay)
 - OV: Ohne Verzögerung (without delay)
- Right side: Level Bombing (Wagrecht)
 - MV: Mit Verzögerung (with delay)
 - OV: Ohne Verzögerung (without delay)
- Middle: Aus (Disarmed)

Bomb Fuze Armed Light

Inner Wing (Innenflügel) Armament Circuit Breaker

Outer Wing (Außenflügel) Armament Circuit Breaker

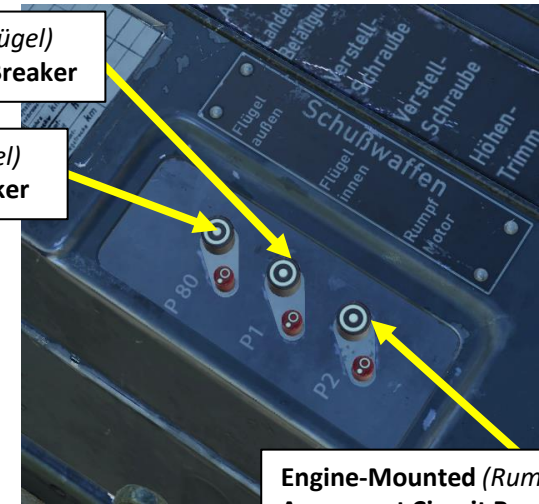

Engine-Mounted (Rumpf Motor) Armament Circuit Breaker

Fuselage Stores (Drop Tanks or Bombs) Jettison Handle

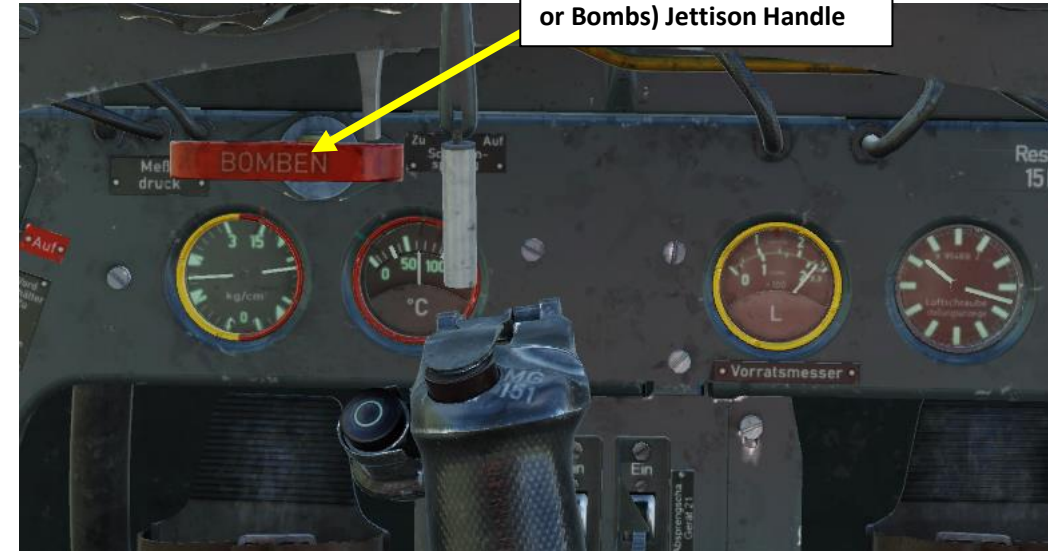

MG 131 MACHINEGUNS (13 MM) & MG 151 CANNONS (20 MM)

1. Verify that the P80 Outer Wing, P1 Inner Wing and P2 Engine-Mounted Armament Circuit Breakers are IN (ON).
2. Arm Machineguns and Inner Wing Cannons by setting the MASTER ARM SAFETY I switch ON (UP)
3. Arm Outer Wing Cannons by setting the MASTER ARM SAFETY II switch ON (UP)
4. Flip the Cannon Safety Cover UP (LSHIFT+SPACE)
5. Adjust Gunsight Brightness – As desired.

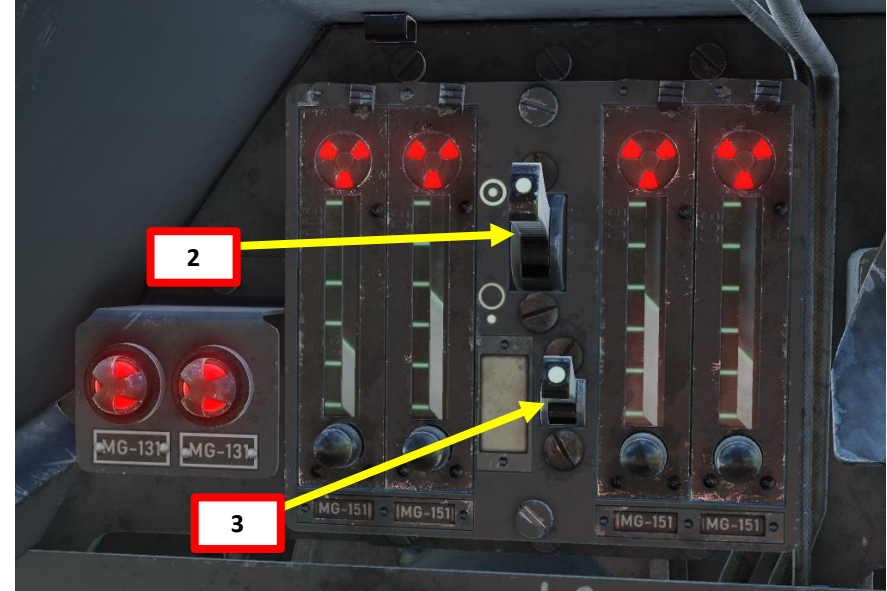
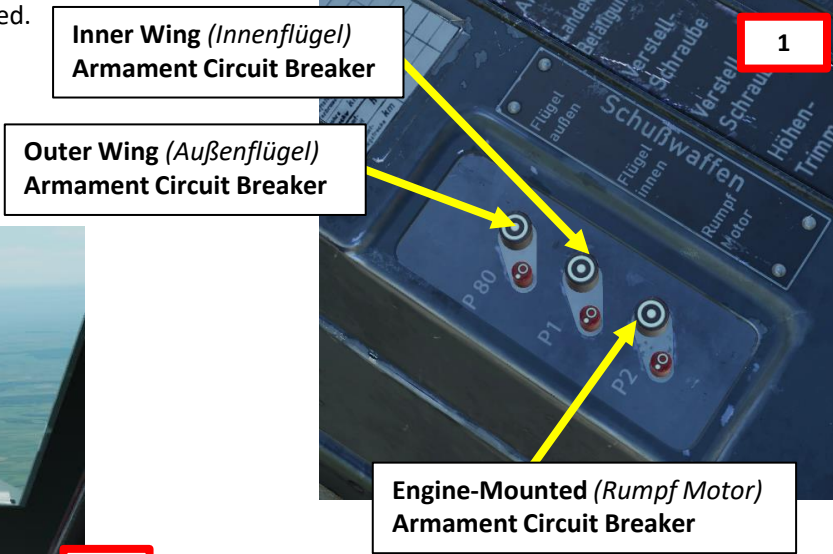

MG 131 MACHINEGUNS (13 MM) & MG 151 CANNONS (20 MM)

6. Place the wings of the target within your gunsight and estimate its range accordingly.



MG 131 MACHINEGUNS (13 MM) & MG 151 CANNONS (20 MM)

- 7. Press the “MG 131/151 Trigger A” button (SPACE) to fire your MG 131 Machineguns and Inner Wing MG 151 Cannons. Press the “MG 151 Trigger B1” button (RALT+SPACE) to fire Outer Wing MG 151 Cannons. Hold both triggers at once to fire all machineguns and cannons at once.

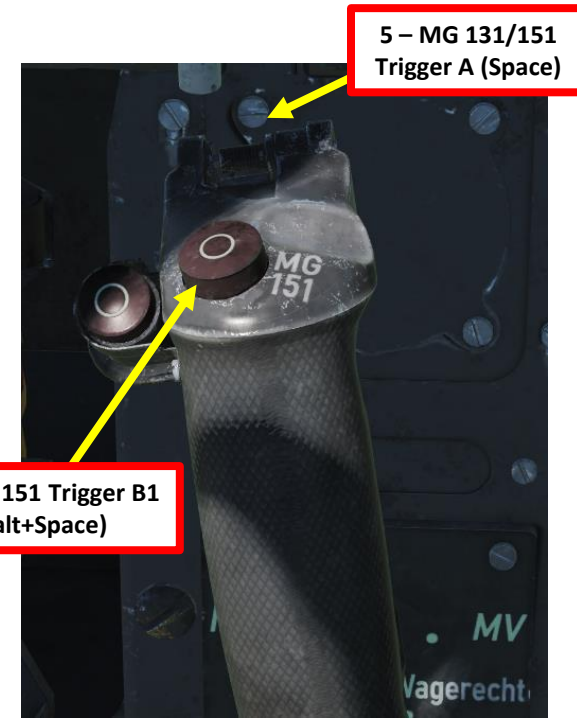

MG 131 MACHINEGUNS (13 MM) & MG 151 CANNONS (20 MM)



ARMAMENT BALLISTICS

Gunfire strike table at 50m and 100m, in cm

Range	Fuselage 2 MG 131		Wing-root 2 MG 151/20		Gond., inner 2 MG 151/20		Gond., outer 2 MG 151/20	
	H ₁	S ₁	H ₂	S ₂	H ₃	S ₃	H ₄	S ₄
0m	95,5	13	-2,5	93	-10,8	237,8	-7	274
50m	121	13	44	85	37	223	41	258
100m	142	13	85	78	78	208	83	244

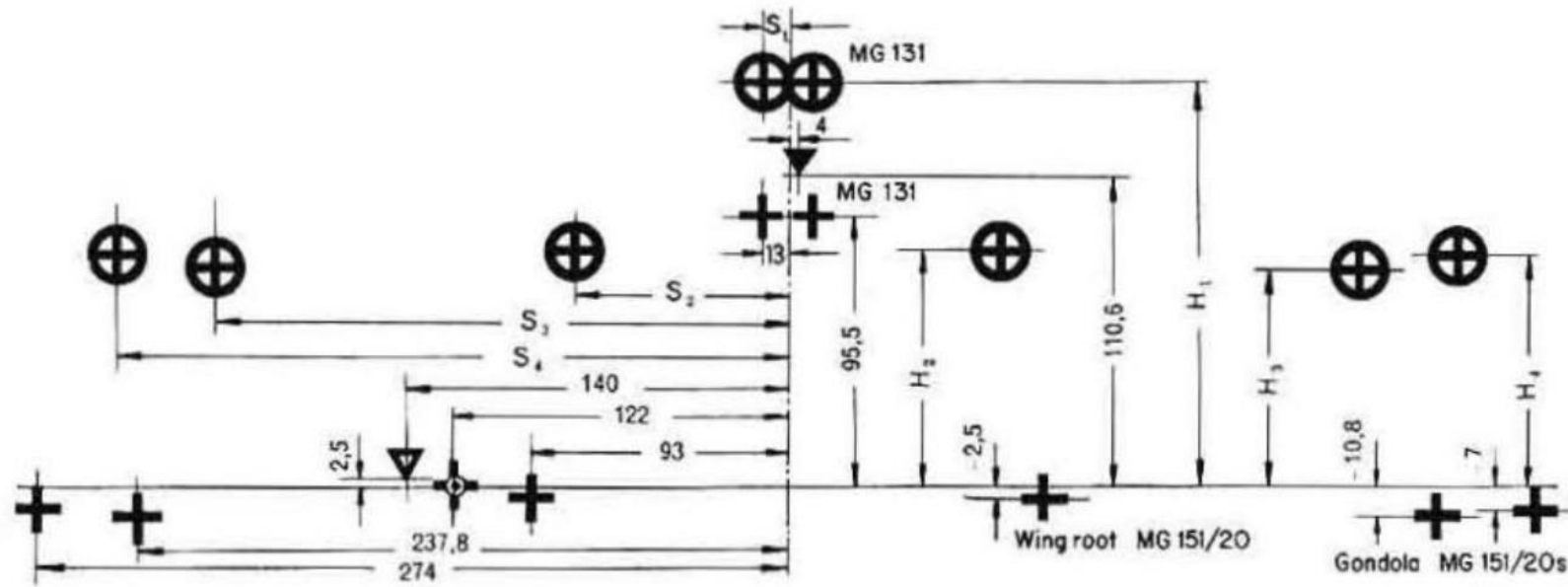

Weapons:
 Fuselage: 2 MG 131
 Wing-roots: 2 MG 151/20
 Gondola, inner: 2 MG 151/20
 Gondola, outer: 2 MG 151/20

Alignments:
 Harmonization 400m, Crossover: parallel
 Harmonization 550m, Crossover: 600m
 Harmonization 550m, Crossover: 800m
 Harmonization 550m, Crossover: 900m

Ammunition:
 13mm Spr.Gr.Ub.El.
 2cm Spr.Gr.Patr.Ub.151
 2cm Spr.Gr.Patr.Ub.151
 2cm Spr.Gr.Patr.Ub.151

Gunfire strike table at 50m and 100m, in cm

ARMAMENT BALLISTICS

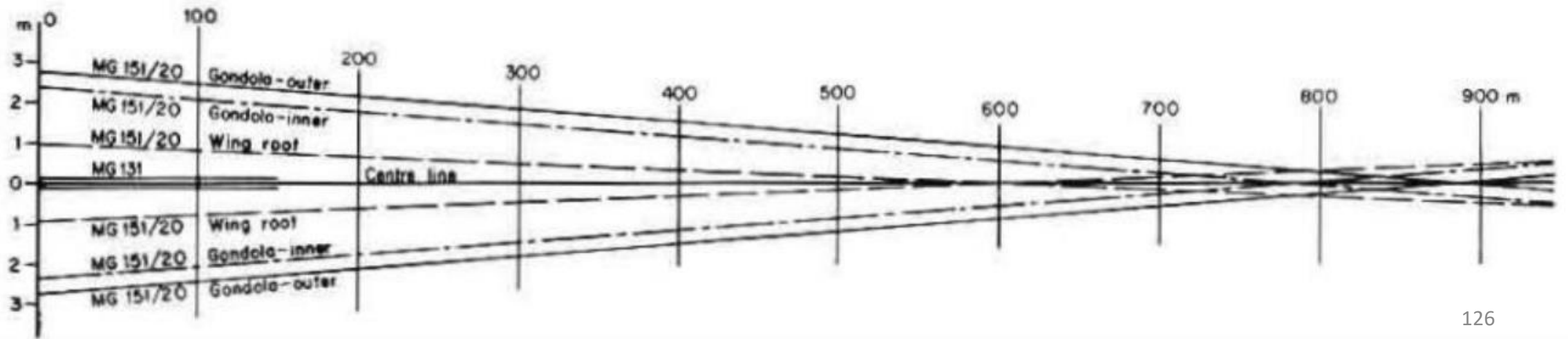
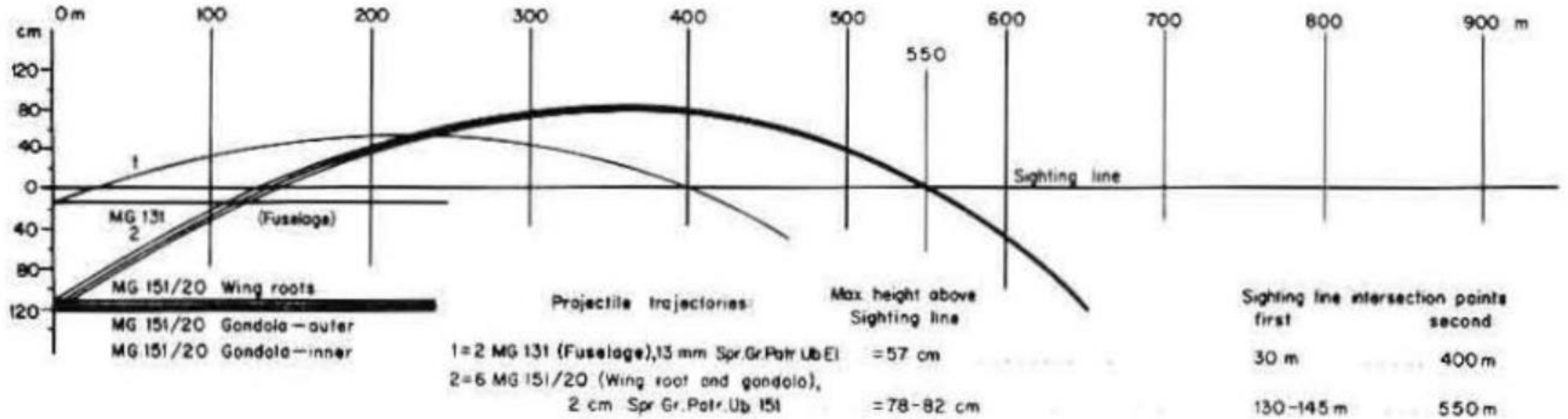

BOMB TYPES

Here is an overview of the bomb types available for the FW190-A8.

Bomb Types	
AB 250-2 (with SD 10A)	<i>Abwurfbehälter</i> (Container Bomb) 250 kg cluster bomb with SD 10A Fragmentation Sub-munitions
AB 250-2 (with SD 2)	<i>Abwurfbehälter</i> (Container Bomb) 250 kg cluster bomb with SD 2 Anti-Personnel Sub-munitions
AB 500-1 (with SD 10A)	<i>Abwurfbehälter</i> (Container Bomb) 500 kg cluster bomb with SD 10A Fragmentation Sub-munitions
SC-50	<i>Sprengbombe Cylindrisch</i> (Cylindrical Explosive) 50 kg general-purpose bomb
SC 250 Type 1 L2	<i>Sprengbombe Cylindrisch</i> (Cylindrical Explosive) 250 kg general-purpose bomb with a Type/Grade 1 two-piece construction.
SC 250 Type 3 J	<i>Sprengbombe Cylindrisch</i> (Cylindrical Explosive) 250 kg general-purpose bomb with a Type/Grade 3 three-piece construction.
SC 500 J	<i>Sprengbombe Cylindrisch</i> (Cylindrical Explosive) 500 kg general-purpose bomb with a J type body.
SC 500 L2	<i>Sprengbombe Cylindrisch</i> (Cylindrical Explosive) 500 kg general-purpose bomb with a L2 type body.
SD 250 Stg	<i>Sprengbombe Dickwandig</i> (Thick Walled Explosive Bomb) 250 kg penetration bomb (delayed fuze)
SD 500 A	<i>Sprengbombe Dickwandig</i> (Thick Walled Explosive Bomb) 500 kg penetration bomb (delayed fuze)

BOMB FUZES

To equip bombs with a fuze delay, contact the ground crew.

1. Open canopy
2. Press “RALT + \” (Communication Push-to-Talk)
3. Select ground crew by pressing “F8”
4. Select “Rearm & Refuel” by pressing “F1”.
5. Equip bomb on desired pylon.
6. Click on the yellow triangle on the bomb to set fuze type and delay.
7. Set fuze type and delay.
8. Click OK on the Fuze panel.
9. Click OK on the Re-Arming panel.

Terminology

- *Sturz*: Dive Bombing
- *MV*: Mit Verzögerung (with fuze delay)
- *OV*: Ohne Verzögerung (without fuze delay)
- *Wagerecht*: Low Level

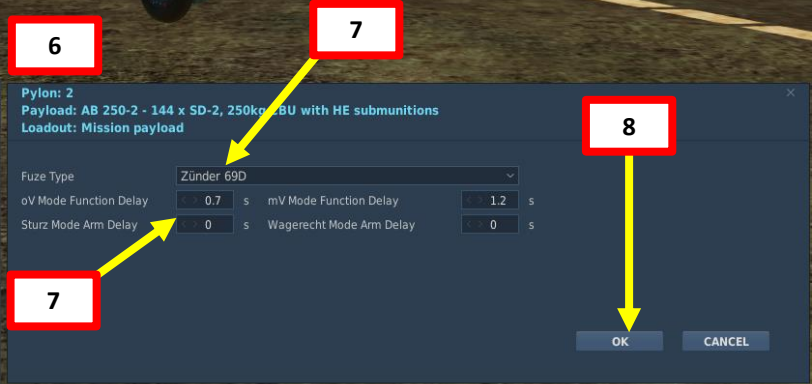
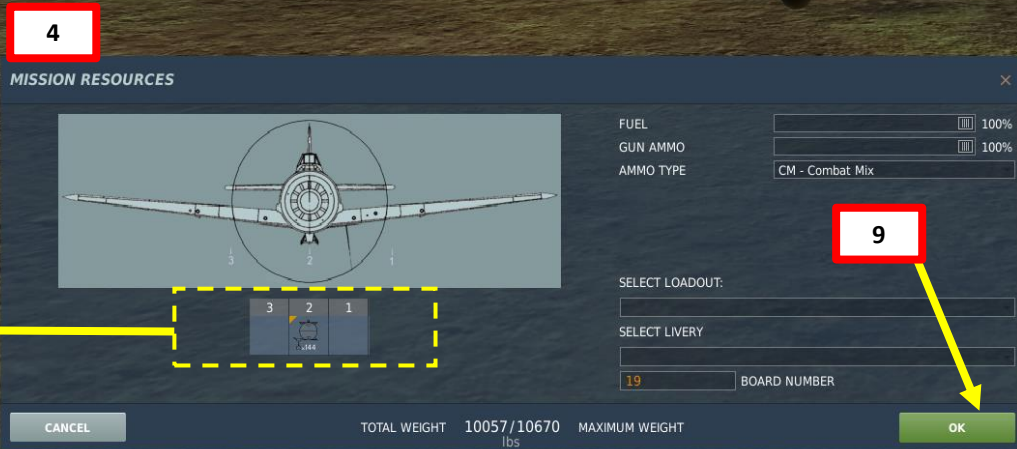
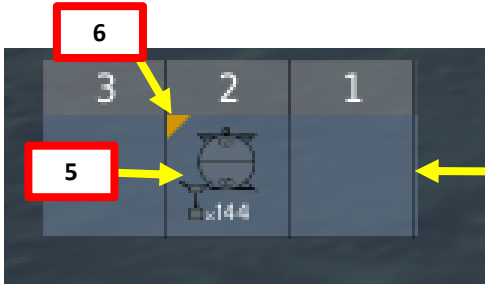
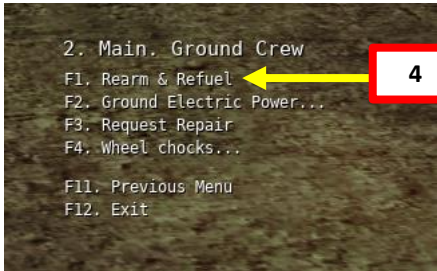
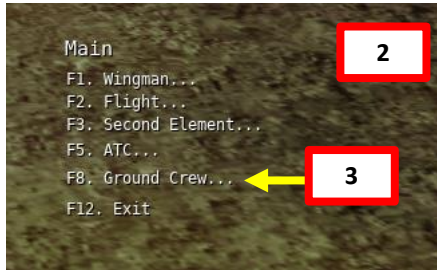

SC-250 BOMB (DIVE BOMBING PROFILE)

1. Set Master Arm Safety I Switch – ON (UP)
2. Choose bomb release mode
 - Left Side (Red) = *Sturz* = Dive Bombing
 - Right Side (Green) = *Wagerecht* = Level Bombing
3. Choose desired fuse delay
 - MV = *Mit Verzögerung* = With Delay
 - OV = *Ohne Verzögerung* = Without Delay
4. Select appropriate release mode on console.
 - Example: *Sturz OV* = Dive Bombing Without Delay

Bomb Release Mode Selector Switch

- Left side: Dive Bombing (*Sturz*)
 - MV: *Mit Verzögerung* (with delay)
 - OV: *Ohne Verzögerung* (without delay)
- Right side: Level Bombing (*Wagerecht*)
 - MV: *Mit Verzögerung* (with delay)
 - OV: *Ohne Verzögerung* (without delay)
- Middle: *Aus* (Disarmed)

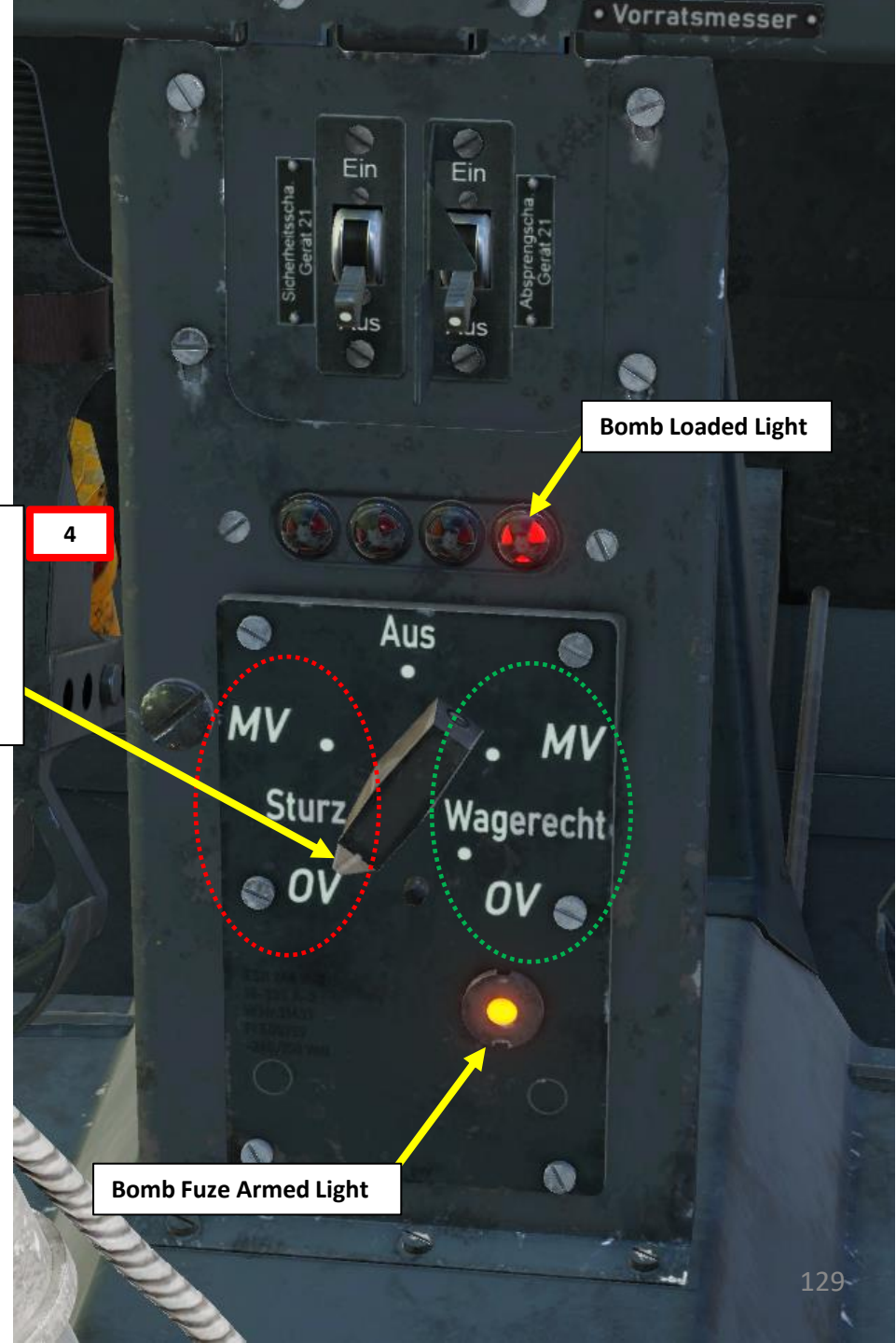
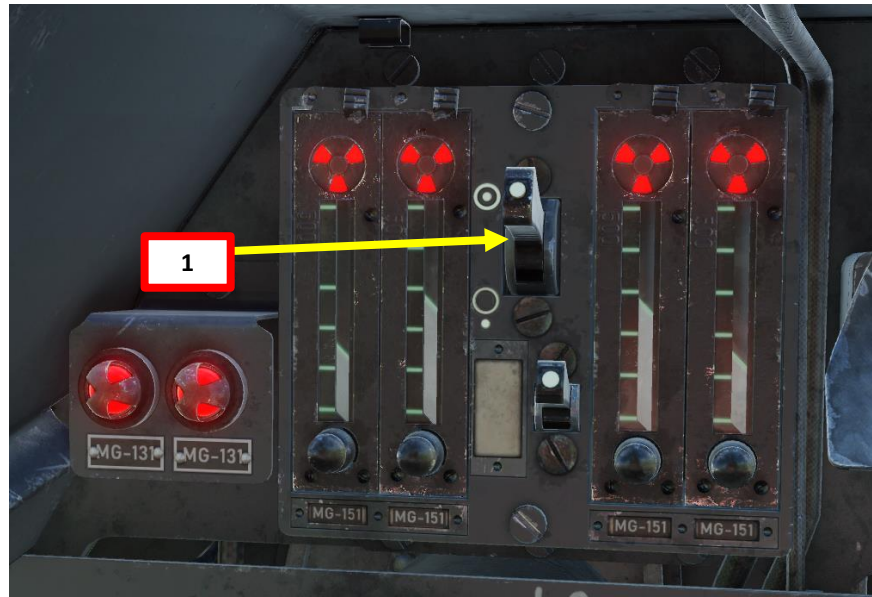

SC-250 BOMB (DIVE BOMBING PROFILE)

5. Approach the target by flying level at an altitude of 2 km, with an airspeed of 350 km/h.
6. When the target disappears under the wing on a line of about 1/3 from the end of the wing-tip, perform a gentle turn under the horizon in the direction of the target.
7. While turning, regulate speed so that the target remains visible. This turn has to be very steady and made without excessive use of the rudder.



SC-250 BOMB (DIVE BOMBING PROFILE)

8. Throttle back at idle power and perform a dive between 45 and 60 degrees. The steeper the dive angle the better precision you will have.
9. Make sure not to exceed maximum diving speeds, as indicated on your airspeed gauge.
10. Line up the target with the center of the gunsight reticle.
11. Pull lead to bring the target slightly under the aircraft nose.
12. When target is lined up under the aircraft nose and aircraft is between an altitude of 500 m and 1 km, release bomb.



Airspeed Indicator (km/h)

Not to Exceed diving speeds are handwritten.

Airspeed @ Altitude

- 500 km/h @ 9 km
- 600 km/h @ 7 km
- 700 km/h @ 5 km
- 800 km/h @ 3 km
- 850 km/h @ 2 km



SC-250 BOMB (DIVE BOMBING PROFILE)

13. Release bomb using the “Bomb Drop B2” button (RSHIFT+SPACE).
14. Apply full power and pull away from the blast while maintaining level flight. This will allow you to get out as quickly as possible from the orbit of enemy anti-air defences.
15. After having travelled enough distance, start climbing. Climbing immediately after the release of bombs was one of the most common mistakes and resulted in:
 - Unnecessary danger to the pilot from the enemy anti-air batteries
 - Black-out
 - Wing wrinkling



13

B2 Button
Bomb/Rocket Release Button

- *RSHIFT+SPACE* binding



BR 21 WERFER-GRANATE 21-CM ANTI-AIR ROCKETS

You can set anti-air rockets with a fuze delay and a self-destruct delay as well. Similarly to the bomb fuze setup, contact the ground crew and click on the yellow triangle on the rocket to set fuze type and delay.

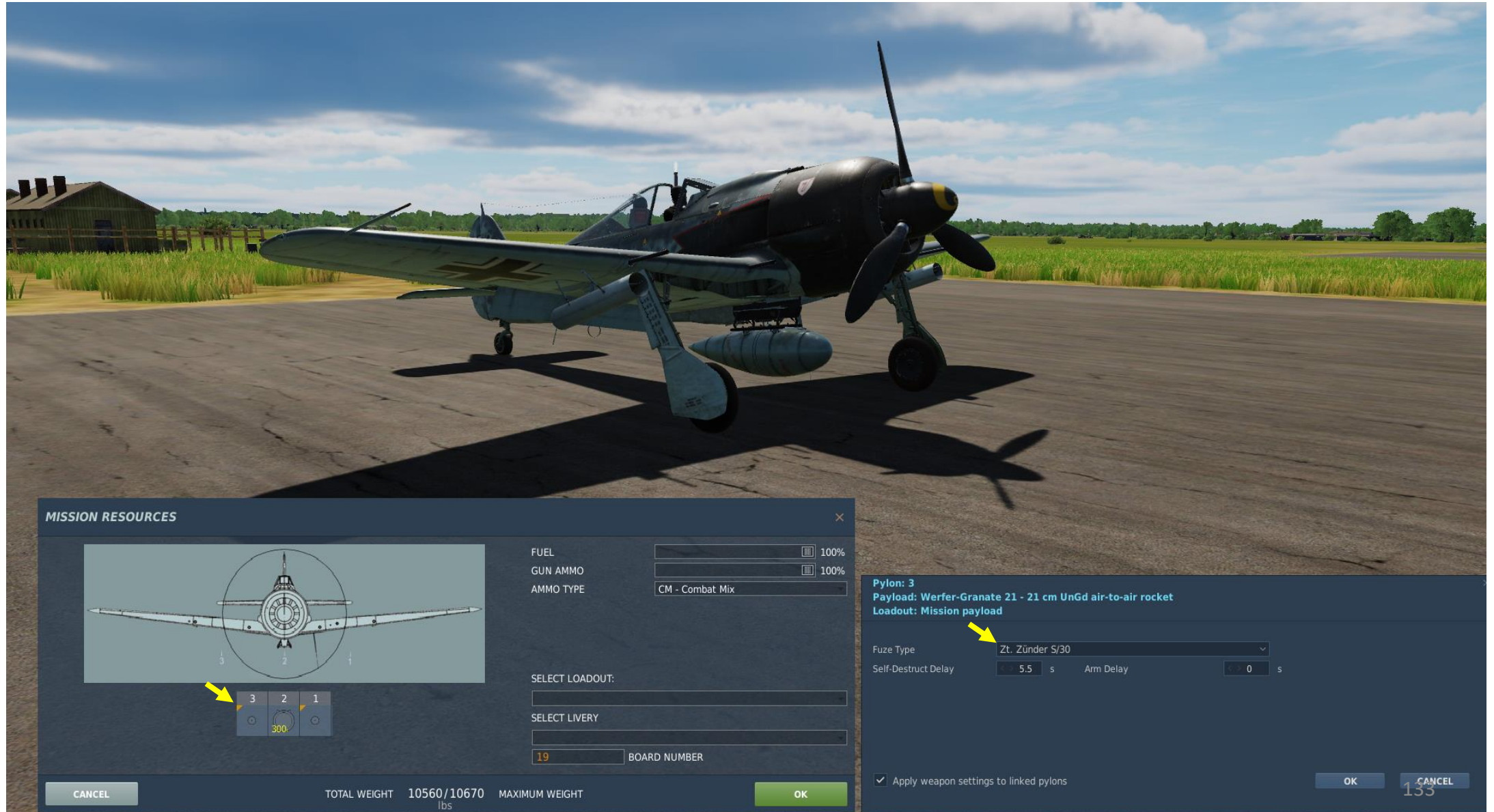

BR 21 WERFER-GRANATE 21-CM ANTI-AIR ROCKETS

1. Arm rockets by setting the “SICHERHEITSSCHA. GERÄT 21” switch to EIN (UP).
2. The aiming process is very imprecise. 21-cm Werfer-Granate Rockets were designed to be used as anti-air rockets against the allied heavy bomber combat boxes. The shots were meant to be taken from a longer range, providing (in theory) a safer alternative to exposed attacks with cannons. The angled-up rocket tubes provided the rocket with an arced trajectory... and the rockets would hopefully damage bombers when exploding in mid-air. Needless to say, this concept was better in theory than in practice since the rockets themselves were not very accurate.

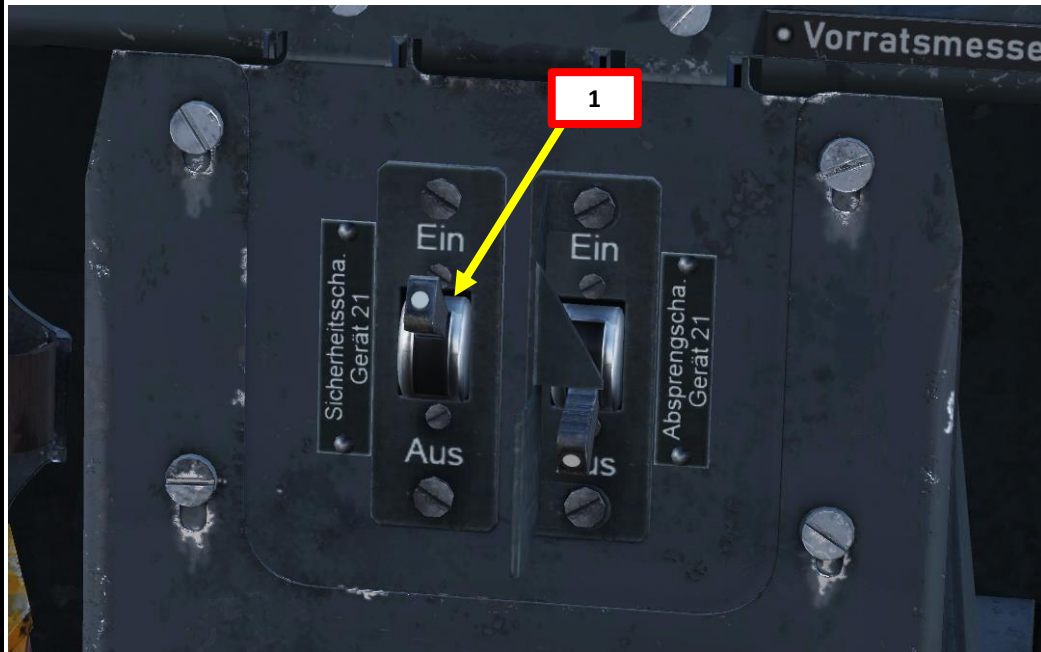

BR 21 WERFER-GRANATE 21-CM ANTI-AIR ROCKETS

3. Press the “Bomb Drop B2” button (RSHIFT+SPACE) to fire rockets.
4. To jettison rocket racks (which generate a lot of drag):
 - a) Verify that Rocket Arming Switch (*SICHERHEITSSCHA. GERÄT 21*) is set to EIN/ARMED (UP)
 - b) Set the “ABSPRENGSCHA. GERÄT 21” switch to EIN (UP) after lifting the safety cover.



B2 Button
Bomb/Rocket Release Button
• RSHIFT+SPACE binding

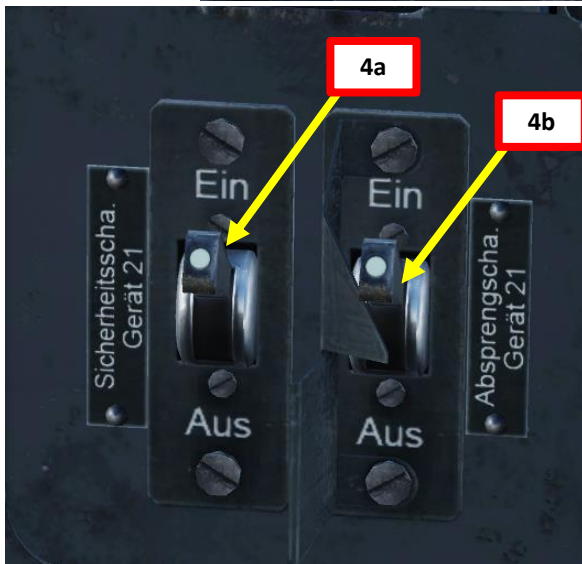

ORDNANCE JETTISON

- To **jettison a bomb**, set Bomb Release Mode Selector Switch to AUS (Disarmed), then pull “BOMBEN” (BOMB/DROP TANK JETTISON) handle.
- To **jettison an external fuel drop tank**, pull “BOMBEN” (BOMB/DROP TANK JETTISON) handle.
- To **jettison rocket racks**, set Rocket Arming Switch (*SICHERHEITSSCHA. GERÄT 21*) to EIN/ARMED (UP) then set the “ABSPRENGSCHA. GERÄT 21” switch to EIN (UP) after lifting the safety cover.

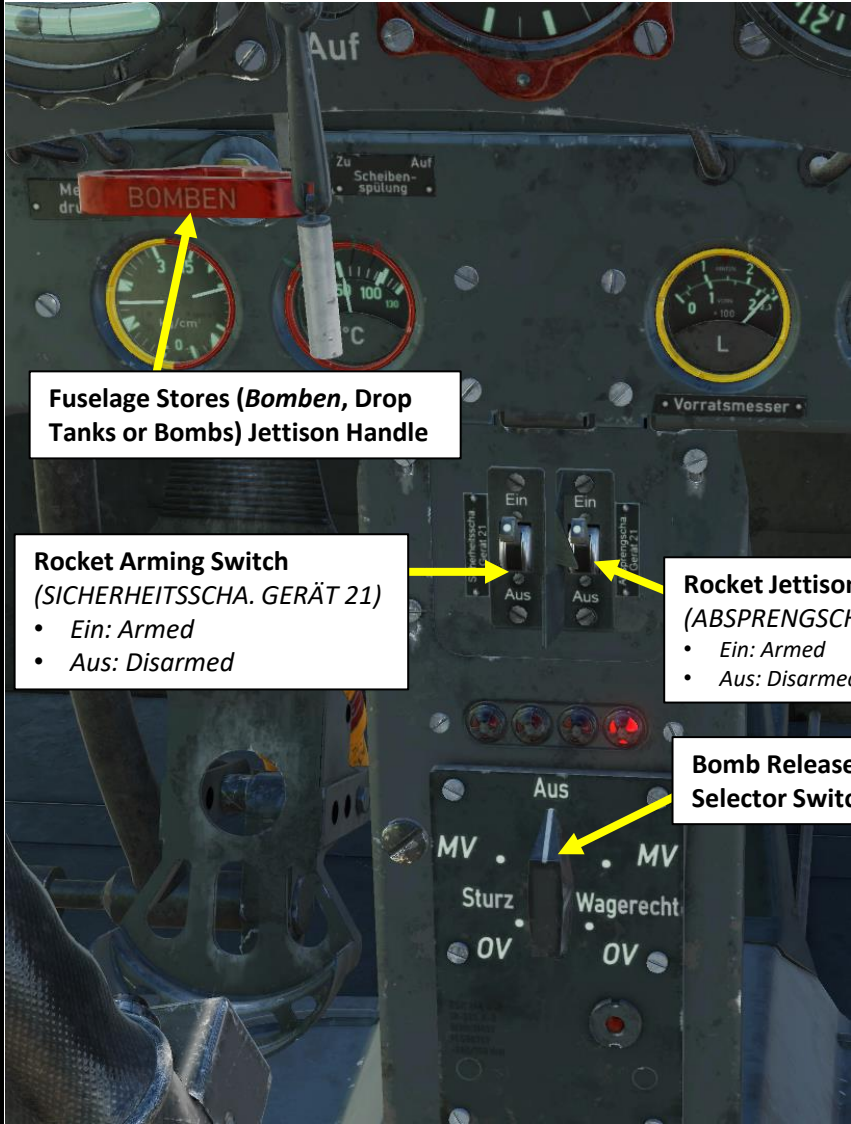

Fuselage Stores (*Bomben*, Drop Tanks or Bombs) Jettison Handle

Rocket Arming Switch (*SICHERHEITSSCHA. GERÄT 21*)
 • *Ein*: Armed
 • *Aus*: Disarmed

Rocket Jettison Switch (*ABSPRENGSCHA. GERÄT 21*)
 • *Ein*: Armed
 • *Aus*: Disarmed

Bomb Release Mode Selector Switch



**RADIO FREQUENCY
RANGE: 38.4- 42.4 MHz**

FUG 16ZY VHF RADIO OVERVIEW

The FW190A-8 is equipped with a FuG 16ZY radio, a specially-designed airborne VHF transceiver. The FuG 16 can be used for in-flight communication as well as for IFF identification and DF homing. The set operates in the frequency range between 38.4 and 42.4 MHz.

The FuG 16ZY can also be set to *Leitjäger* or Fighter Formation Leader mode that allows it to use a special *Y-Verfahren* ground tracking and direction homing via the normal headphones.

Radio frequencies are **preset** in the mission editor in **4 different channels** and **cannot be tuned manually during flight**.

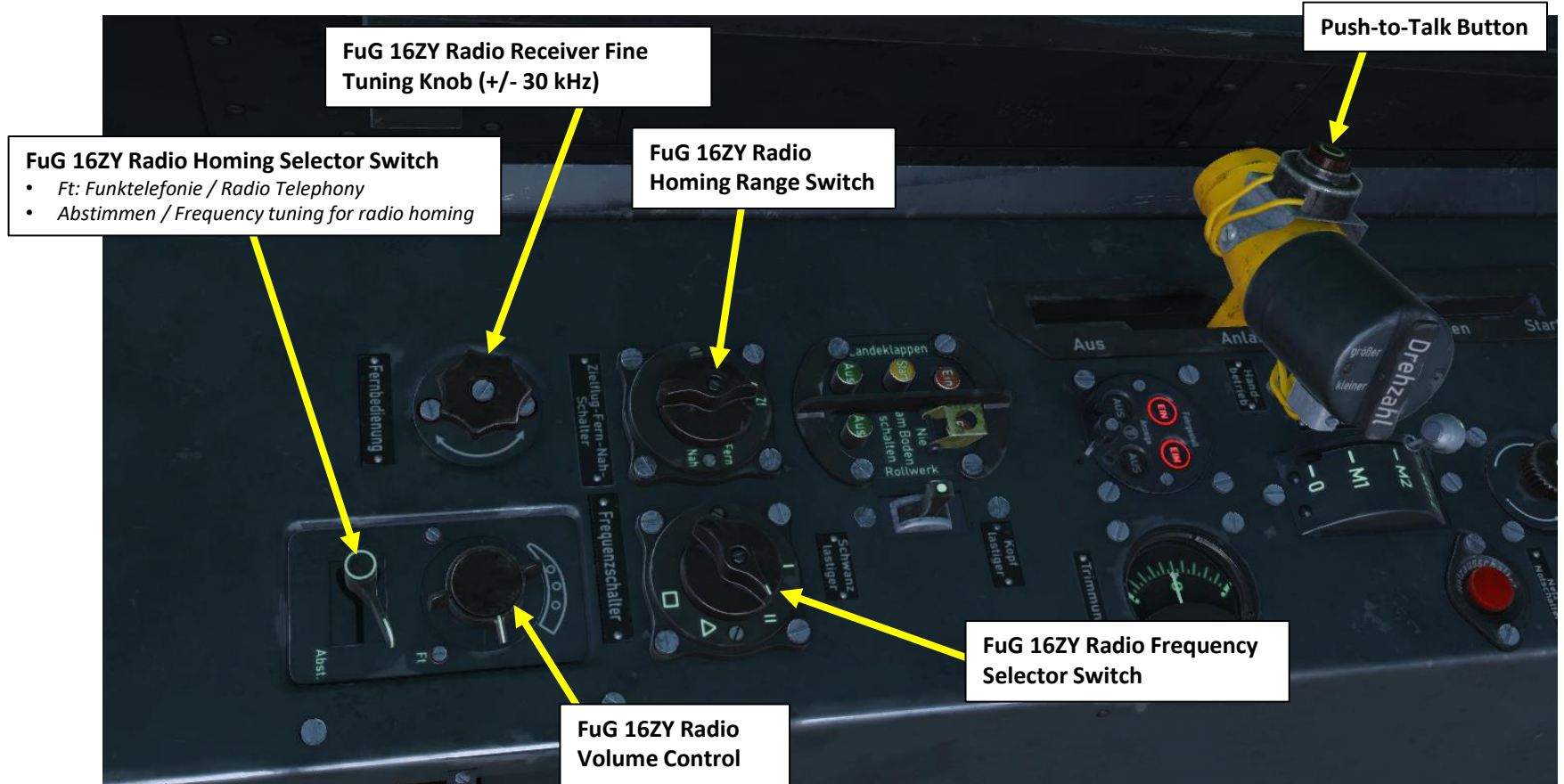

HOW TO TRANSMIT ON FUG 16ZY VHF RADIO

1. Set FUG 16ZY Power Switch (FT-Anlage) ON.
2. Set radio channel selector to the desired frequency (I, II, Δ or □).
 - See note on next page about the real-life functions of these frequencies.
3. Set radio mode to “FT” (FUNKTELEFONIE: RADIO TELEPHONY)
4. Adjust radio volume as desired.
5. Press the Push-to-Talk Button on your throttle to transmit (“COMM PUSH TO TALK” Binding, or “RALT+N”)

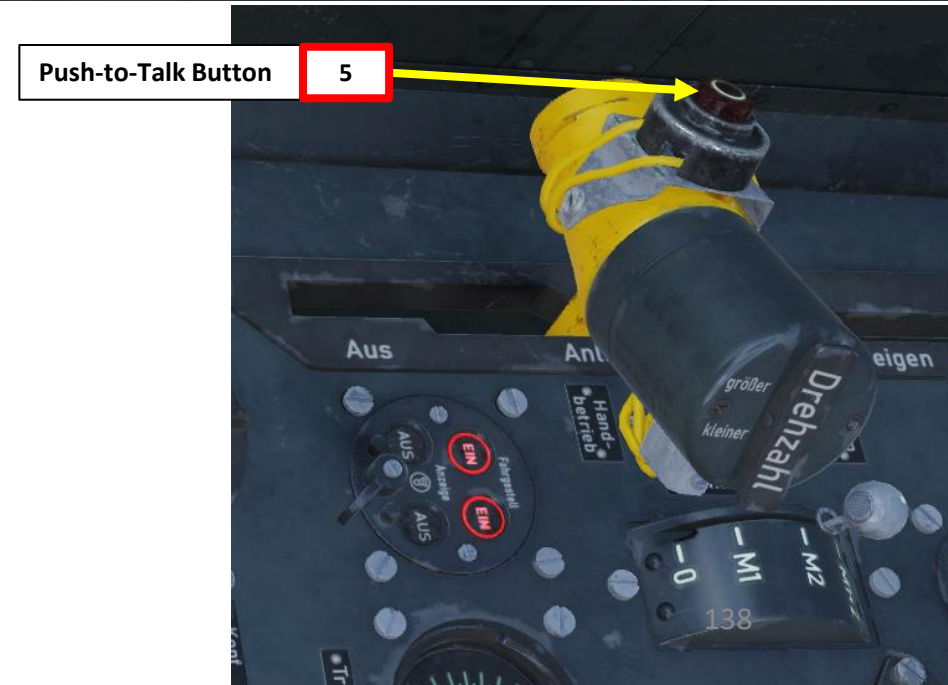
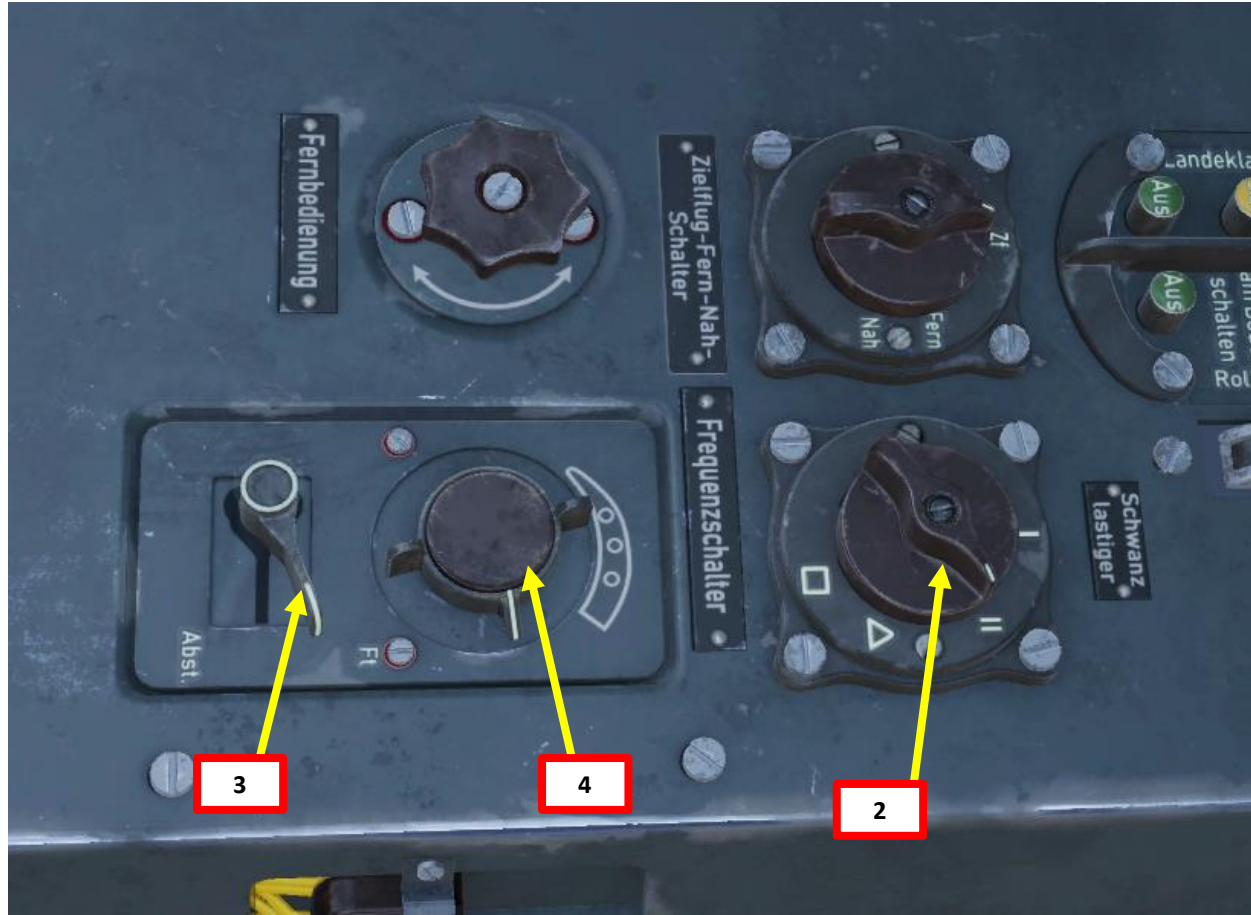

FUG 16ZY RADIO CHANNELS

- The "I" position is for "*Y-Führungsfrequenz*", or Management frequency, is used for communication within the flight or squadron. A mission maker will typically preset this frequency to the same frequency used by your wingmen of your flight and mention it in the mission briefing.
- The "II" position is for "*Gruppenbefehlsfrequenz*", or Group Order frequency, is used to communicate between several flights from different squadrons participating in a single raid. A mission maker will typically preset this frequency to the same frequency used by other flights or friendly units and mention it in the mission briefing.
- The "Δ" position is for "*Nah-Flugsicherungsfrequenz*", or the Air Traffic Control frequency. It is used to communicate with the designated Air Traffic Controller. A mission maker will typically preset this frequency to the same frequency used by your departure airfield and mention it in the mission briefing.
- The "□" position is for "*Reichsjägerfrequenz*", or Reich Fighter Defense Frequency, and is used to coordinate country-wide air defense efforts in large scale raids.

These frequencies should be listed in your mission briefing.

Homing Switch	Frequency Selector	Push-To-Talk Open	Push-To-Talk Depressed	Transm	Recvr
"Ft"	I	Listen	Talk	I	II
"Abst"	I	Homing Listen	Homing Listen+Talk	I	II
"Ft"	II, Δ or □	Listen	Talk	II, Δ or □	
"Abst"	II, Δ or □	Listen to loop antenna Targeting	Talk	II, Δ or □	

Because on the first frequency selector position (I) sending and receiving are conducted at different frequencies, it is not used in this simulation.

For communication, use II, Δ or □ selector positions with "Ft" position of communications - homing switch.

AIRPLANE GROUP

NAME:

CONDITION: % 100

COUNTRY:

TASK:

UNIT: OF

TYPE:

SKILL:

PILOT:

TAIL #: COMM: MHz

CALLSIGN:

HIDDEN ON MAP

HIDDEN ON PLANNER

LATE ACTIVATION

FuG 16

Channel 1	< > 39	MHz	AM
Channel 2	< > 38.4	MHz	AM
Channel 3	< > 41	MHz	AM
Channel 4	< > 42	MHz	AM
AFN2 Base Frequency	< > 38	MHz	AM

AIRPORT RADIO FREQUENCIES

To determine airport radio frequencies, use the F10 map.



AIRFIELD	FREQUENCY
Anapa	38.40 MHz
Batumi	40.40 MHz
Beslan	42.40 MHz
Gelendzhik	39.40 MHz
Gudauta	40.20 MHz
Kobuleti	40.80 MHz
Kutaisi	41.00 MHz
Krasnodar-Center	38.60 MHz
Krasnodar-Pashkovsky	39.80 MHz
Krymsk	39.00 MHz
Maykop	39.20 MHz
Mineralnye Vody	41.20 MHz
Mozdok	41.60 MHz
Nalchik	41.40 MHz
Novorossiysk	38.80 MHz
Senaki	40.60 MHz
Sochi	39.60 MHz
Soganlug	42.00 MHz
Sukhumi	40.00 MHz
Tbilisi	41.80 MHz
Vaziani	42.20 MHz



THE REPEATER COMPASS

Most of the navigation must be done visually in the FW190. Consult the Repeater Gyrocompass. If desired, you can adjust your course setting by rotating the outer ring of the Repeater Compass. You can then steer the aircraft until the Aircraft Magnetic Heading needle (front of the airplane symbol) is lined up with the Course Setting reference mark.

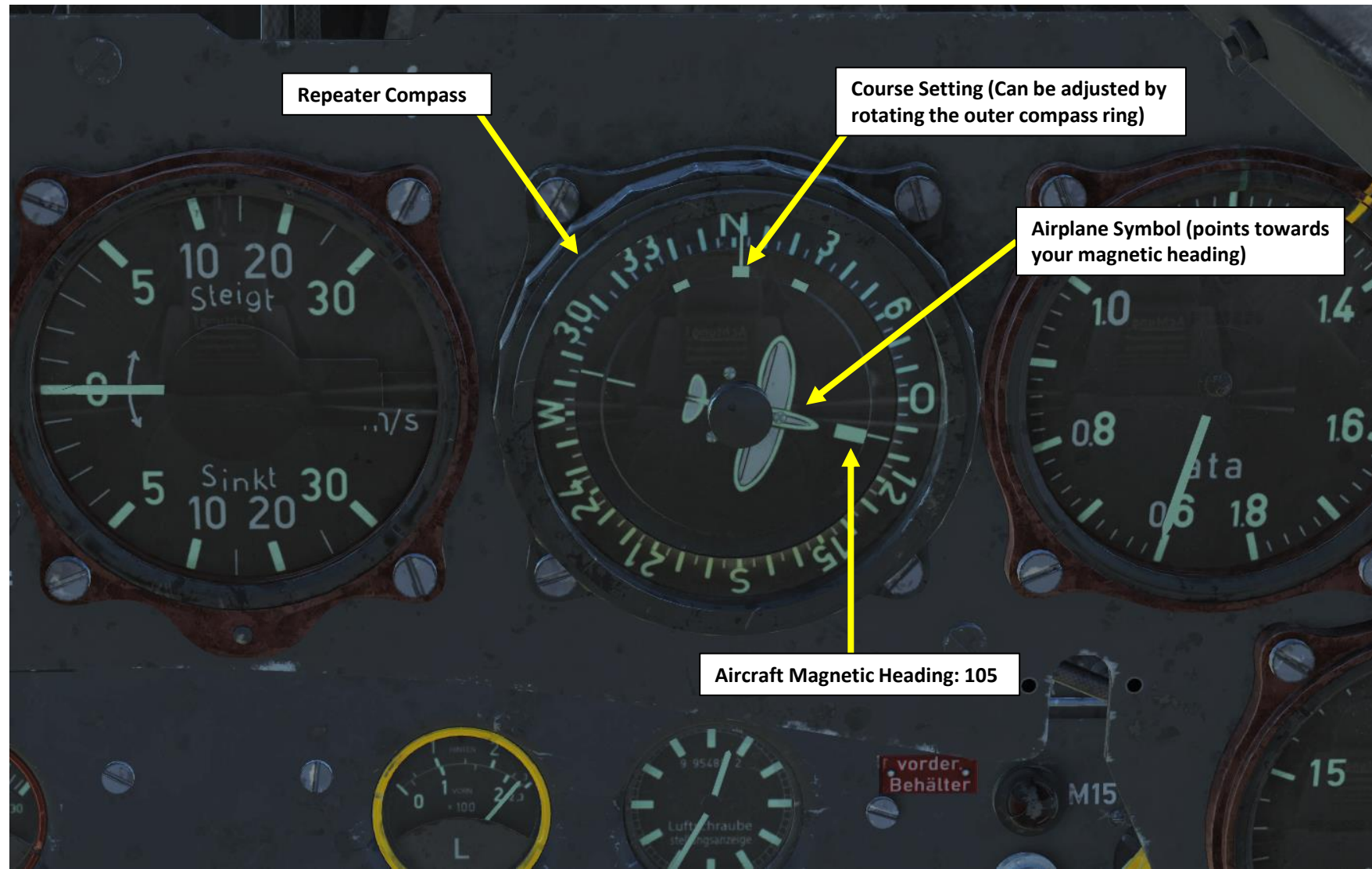

LORENZ BEAM BLIND-LANDING RADIO NAVIGATION (THEORY)

The During the 1930s and 1940s, a Standard Beam Approach (SBA) receiver was used by aircraft, to land when visual conditions were poor (due to rain, low cloud, or fog). It was a navigation receiver, and allowed the pilot to line the aircraft up on the runway when preparing in to land. You can think of it like a primitive form of ILS (Instrument Landing System), but only with a lateral component.

The most important pre-war Navigation Aid (navaid) was the Lorenz Radio Range, developed in Germany as a Blind Landing System (BLS), and was used extensively in Europe. It was developed starting in 1932 by Dr. Ernst Kramar of the Lorenz company. It was adopted by Lufthansa in 1934 and installed around the world. Lorenz used a 33.33 MHz radio transmitter, which projected two overlapping beams down the runway. The beams were switched on and off alternately, the left beam creating "*dits*" (morse letter E), the right beam creating "*dahs*" (morse letter T). Where the beams overlapped along the runway centerline, a continuous tone was heard.

On approach, when the pilot heard *dits*, he turned right until he heard the steady tone. Similarly if he heard *dahs*, he turned left. This was an aural navigation method, meaning that you used the morse signal sounds to determine whether you were to the left, to the right or directly lined up with the runway center. The pilot had to listen to the tones in his earphones and fly accordingly.

The Lorenz system was installed at many British airfields and called Standard Beam Approach (SBA). It used the morse letter A (*dit dah*) for the left beam, and the morse letter N (*dah dit*) for the right beam. In the middle, these overlapped to form the steady tone.

Reference: http://www.tuberadio.com/robinson/museum/command_SBA/

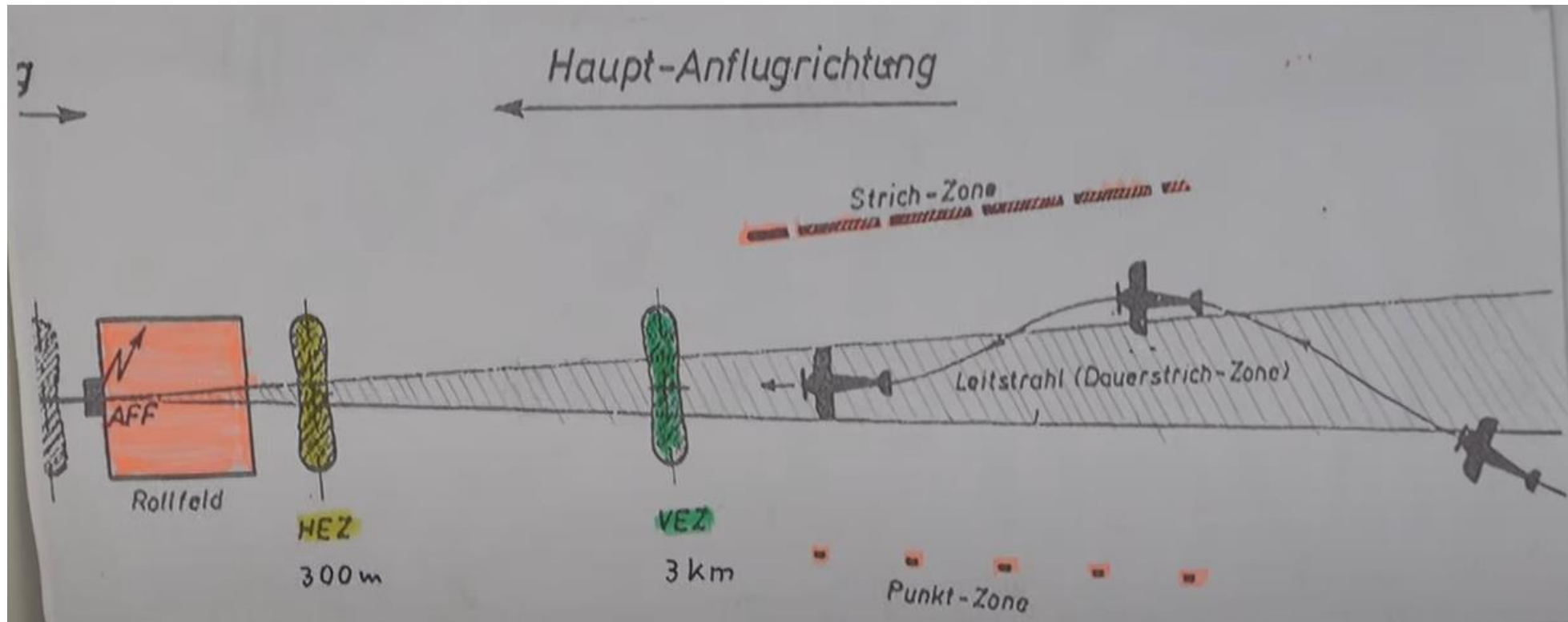

LORENZ BEAM BLIND-LANDING RADIO NAVIGATION (THEORY)

Consult this video for a great explanation of how the Lorenz "Beam" Blind Landing System FuBl 2 was used with the AFN-1 Indicator: <https://youtu.be/6ReAJWnFGpg>

An important point to remember is that **beam landing is not fully functional in DCS yet**, so all these concepts are only the theory of what you would expect.

AFN-1 Homing Indicator



Aircraft is left of correct approach

Lateral Deviation Needle Oscillates to the left

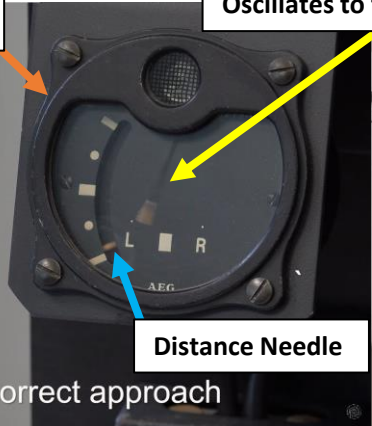

Left of approach pilot hears dots

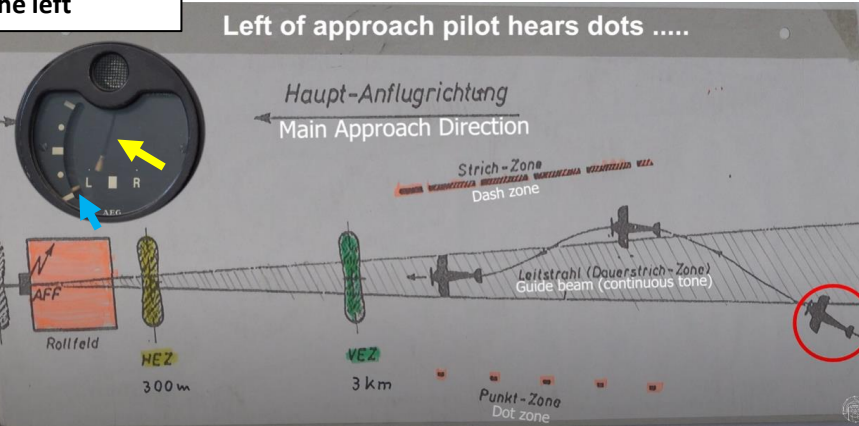

Haupt-Anflugrichtung
Main Approach Direction

Strich-Zone
Dash zone

Leitstrahl (Dauerstrich-Zone)
Guide beam (continuous tone)

Punkt-Zone
Dot zone

Beacon/Marker Light

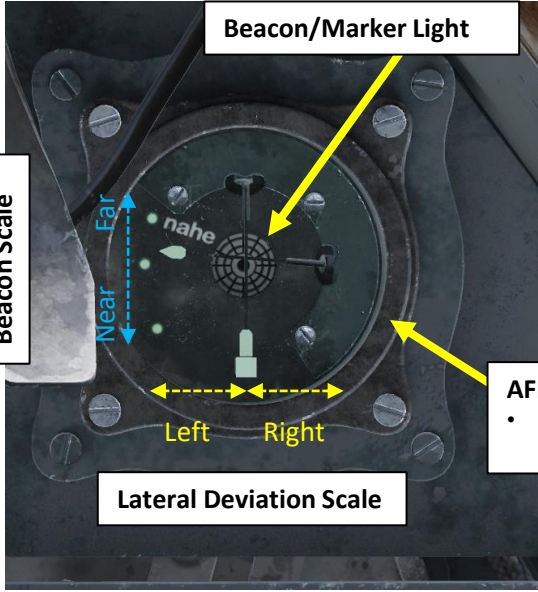

Distance from Beacon Scale

nahe
Near

fern
Far

Left Right

Lateral Deviation Scale

AFN-2 Homing Indicator

- Used to determine where aircraft is in relationship to airport.

Right of approach pilot hears dashes _ _ _ _

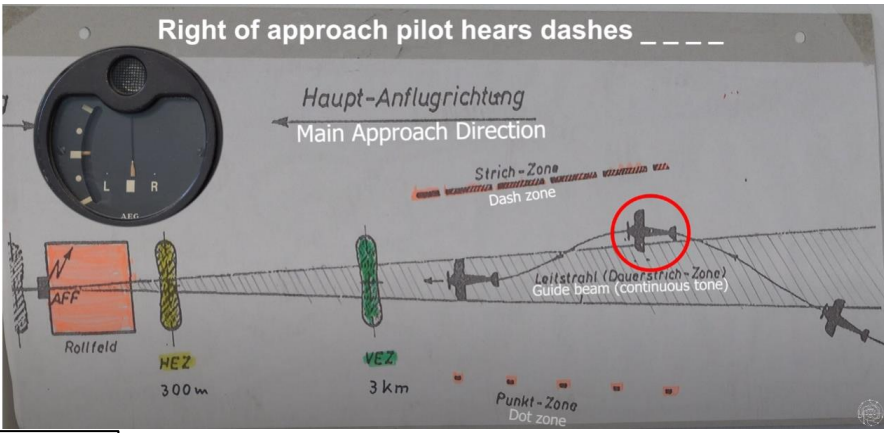

Haupt-Anflugrichtung
Main Approach Direction

Strich-Zone
Dash zone

Leitstrahl (Dauerstrich-Zone)
Guide beam (continuous tone)

Punkt-Zone
Dot zone

Marker Light

- Illuminates when flying over marker beacon (VEZ or HEZ)

Aircraft on correct approach



Aircraft arrives at 3km beacon



On correct approach pilot hears continuous tone _ _ _ _

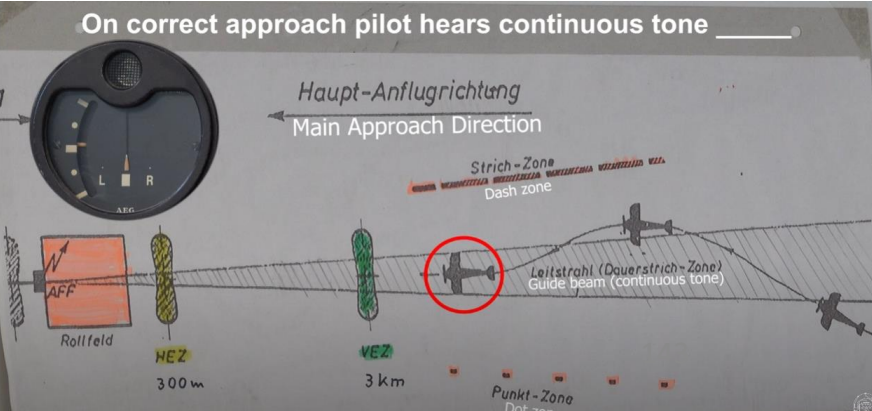

Haupt-Anflugrichtung
Main Approach Direction

Strich-Zone
Dash zone

Leitstrahl (Dauerstrich-Zone)
Guide beam (continuous tone)

Punkt-Zone
Dot zone

LORENZ BEAM BLIND-LANDING RADIO NAVIGATION (THEORY)

Here is an example of the concept behind the Standard Beam Approach (SBA).

The Standard Beam Approach system currently simulated in DCS is based on the Lorenz signals: a series of "dits" (Morse code for "E") for the station right of the runway and a series of "dahs" (Morse code for "T") for the station left of the runway.

The signal codes might change eventually, but the method remains the same: use audio signals to determine where you are in relationship to the runway, and steer the aircraft until both signals overlap and create a steady aural tone.

You can also use the AFN-2 Homing Indicator for visual guidance, which provides direction and range information to the runway.

Here is a useful tutorial by Reflected Simulations for the Mosquito:
<https://youtu.be/tGXSLKSiRk?t=737>

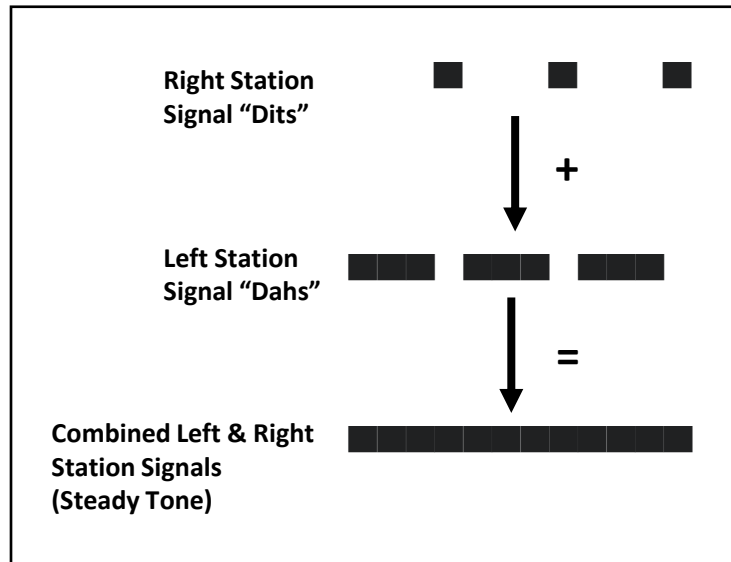

International Morse Code

1. The length of a dot is one unit.
2. A dash is three units.
3. The space between parts of the same letter is one unit.
4. The space between letters is three units.
5. The space between words is seven units.

A	• —	U	• • —
B	— • • •	V	• • • —
C	— • — •	W	• — • —
D	— • • •	X	— • • —
E	•	Y	— • — —
F	• • — •	Z	— — • •
G	— — • •		
H	• • • •		
I	• •		
J	• — — —		
K	— • — —		
L	• — • •		
M	— —		
N	— •		
O	— — —		
P	• — — •		
Q	— • — •		
R	• — • •		
S	• • • •		
T	—		

1	• — — —
2	• • — —
3	• • • —
4	• • • •
5	• • • •
6	— • • •
7	— • — •
8	— • — •
9	— • — •
0	— — — —

Aircraft flying in Right Beam Only

- Signal "Dits" audible
- Signal "Dahs" not audible

Aircraft flying in Left Beam Only

- Signal "Dits" not audible
- Signal "Dahs" audible

Aircraft flying in Both Left & Right Beams (aligned with runway centerline)

- Signal "Dits" and "Dahs" are both audible
- Both signals overlap, creating a steady signal tone.

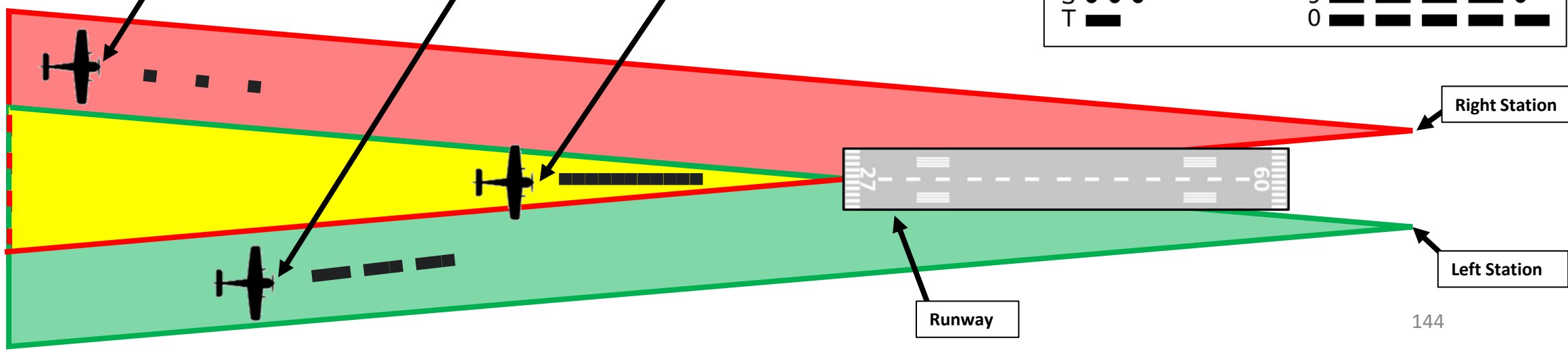

AFN-2 HOMING TUTORIAL (THEORY)

In the aircraft, there is no way to manually tune the frequency use for the Beam Approach system. The frequency is preset via the Mission Editor for the airfield you plan to return to. Since each frequency is different from airfield to airfield, you can only use the beam approach for one single runway.

DCS currently simulates the Beam Approach frequency by using the ILS (Instrument Landing System) frequency of airfields equipped with ILS equipment. The frequencies are not compatible with the frequency range of the FuG 16 radio, but this example is just for illustrative purposes.

- Take note that the **Normandy and Channel maps do not have the Beam Approach beacons yet.**

AIRDROME DATA		FG94
NAME	Kobuleti	
ICAO	UG5X	
COALITION	Neutral	
ELEVATION	59 ft	
RWY Length	7406 ft	
COORDINATES	41°55'55"N 41°52'35"E	
TACAN	67X (KBL)	
VOR	--	
RSBN	--	
ATC	4.350, 133.000, 40.800, 262.000	
RWYs	25	7
ILS	--	111.50 (IKB)

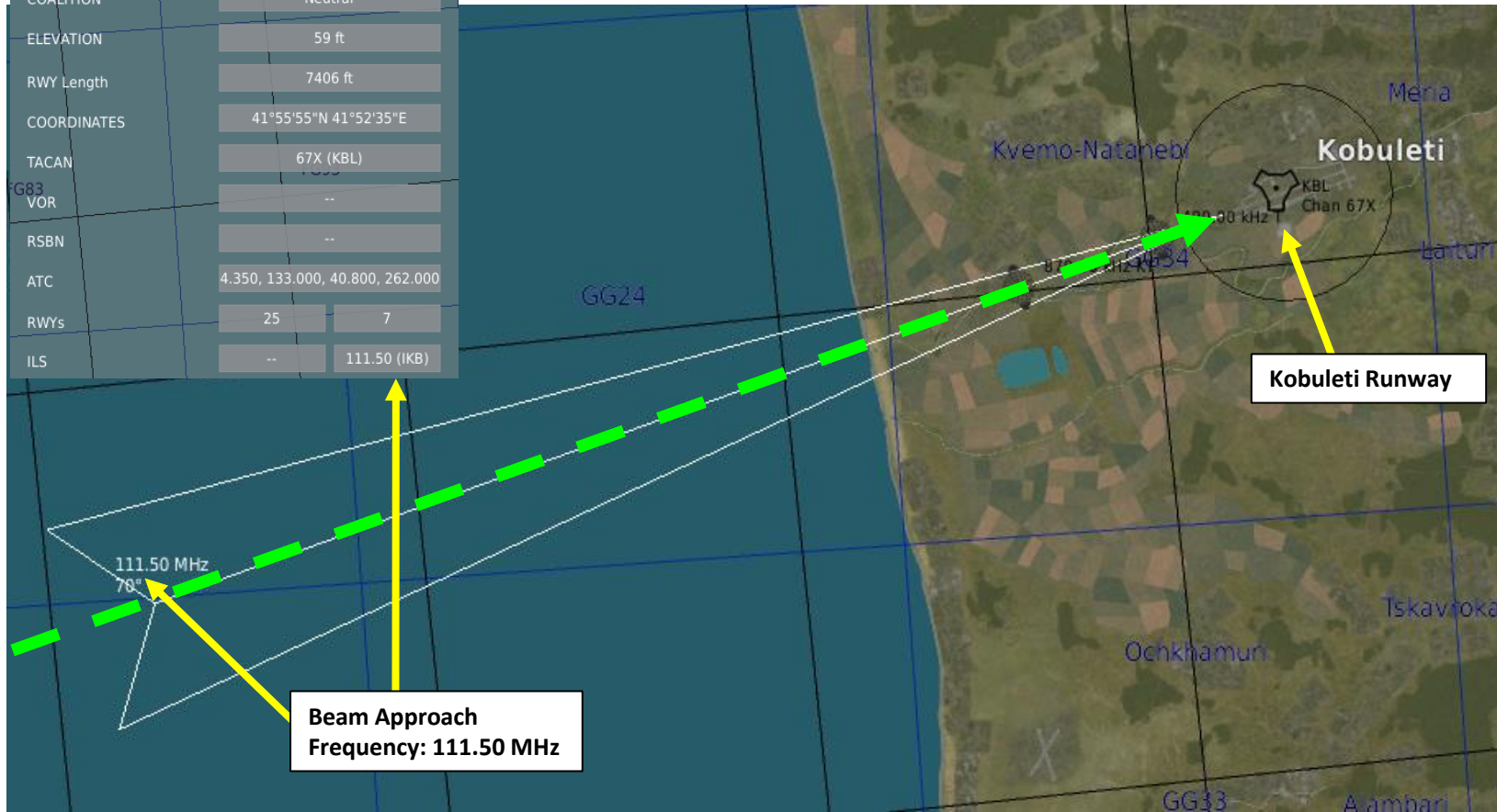

AIRPLANE GROUP

GROUP NAME: Aerial-1

CONDITION: % <> 100

COUNTRY: Combined Joint Task Forces **COMBAT**

TASK: CAP

UNIT: <> 1 OF <> 1

TYPE: Fw 190 A-8

SKILL: Client

PILOT: Aerial-1-1

TAIL #: 19

RADIO: FREQUENCY: 38.4 MHz AM

CALLSIGN: Enfield 1 1

HIDDEN ON MAP

HIDDEN ON PLANNER

HIDDEN ON MFD LATE ACTIVATION

PASSWORD

FuG 16 Z

Channel 1: <> 39 MHz AM

Channel 2: <> 38.4 MHz AM

Channel 3: <> 41 MHz AM

Channel 4: <> 42 MHz AM

AFN-2 Base Frequency: <> 111.5 MHz AM

Beam Approach Frequency: 111.50 MHz

AFN-2 HOMING TUTORIAL (THEORY)

In this tutorial, we will use the Beam Approach system for Kobuleti's runway (frequency 111.50 MHz).

1. Make sure the AFN-2 Base Frequency for the Beam Approach system is set up correctly via the Mission Editor. The AFN-2 Base Frequency should match the Kobuleti ILS frequency, which is 111.50 MHz.
2. Set FUG 16ZY Power Switch (FT-Anlage) ON.
3. Set radio channel selector to II.
4. Set radio mode to "ABST" (Abstimmen: Frequency tuning for radio homing)
5. Adjust radio volume to hear the morse signals from the runway.

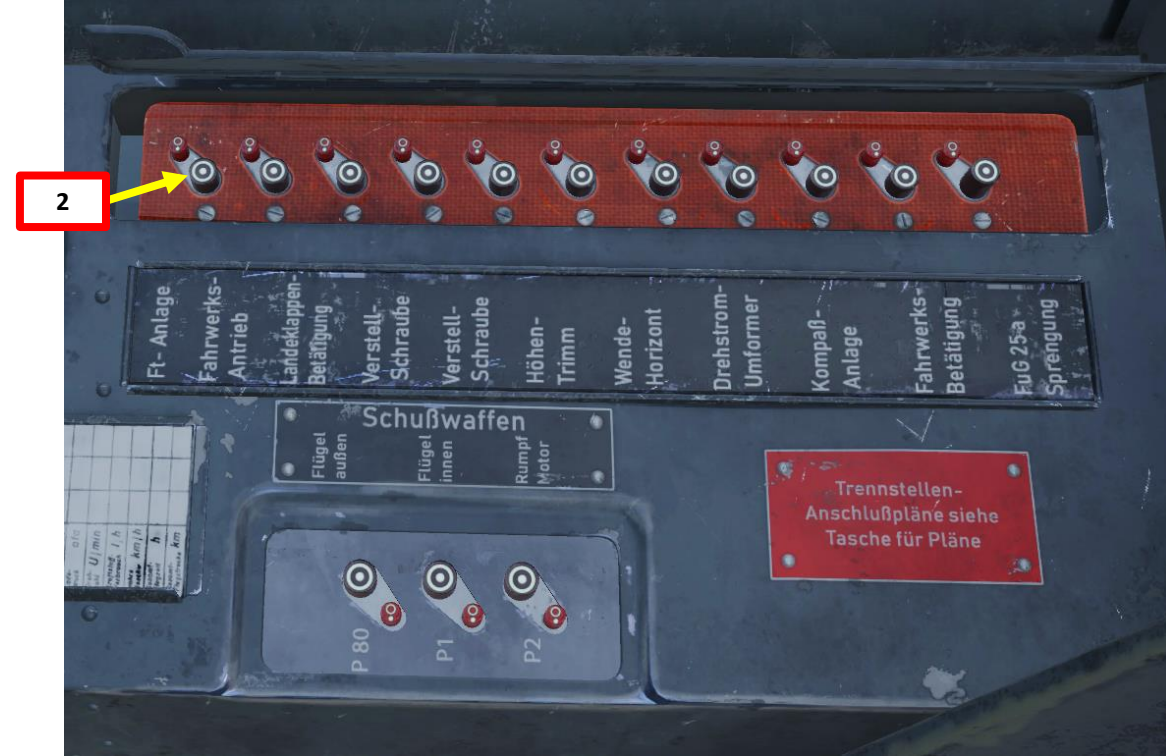

AIRDROME DATA		FG94
NAME	Kobuleti	
ICAO	UG5X	
COALITION	Neutral	
ELEVATION	59 ft	
RWY Length	7406 ft	
COORDINATES	41°55'55"N 41°52'35"E	
TACAN	67X (KBL)	
G83 VOR	--	
RSBN	--	
ATC	4.350, 133.000, 40.800, 262.000	
RWYs	25	7
ILS	--	111.50 (IKB)

FuG 16 Z			
Channel 1	< >	39	MHz AM
Channel 2	< >	38.4	MHz AM
Channel 3	< >	41	MHz AM
Channel 4	< >	42	MHz AM
AFN-2 Base Frequency	< >	111.5	MHz AM

Beam Approach
Frequency: 111.50 MHz

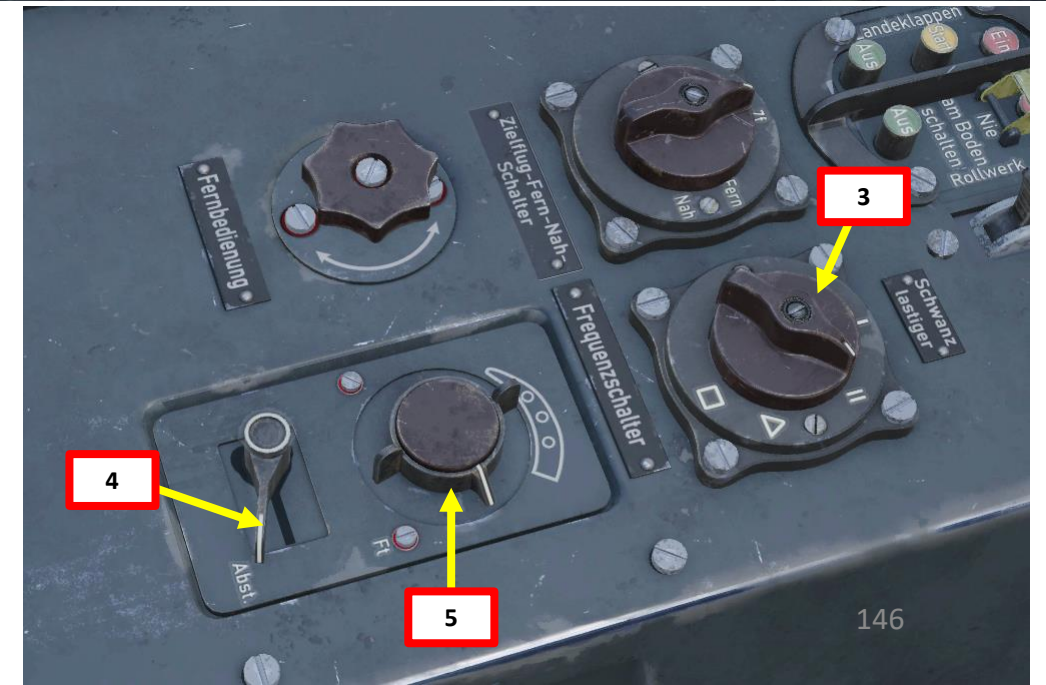

AFN-2 HOMING TUTORIAL (THEORY)

- Determine your current position based on what kind of audio signal you hear:
 - A series of short “dits” (Morse code for “E”) is for the station right of the runway. This means the runway is further to your right.
 - A series of long “dahs” (Morse code for “T”) for the station left of the runway. This means the runway is further to your left.
 - A steady tone means both the left and right station signals overlap, which means that you are lined up with the runway.
- The AFN-2 Homing Indicator will also provide you guidance towards the runway. See next page for more information.
- The Beam Approach gives you your position relative to the runway, but it does not indicate whether you are flying in the correct direction or not. To ensure the aircraft heading is correct, make sure to use the Repeater Compass to follow the Magnetic Heading of Kobuleti’s runway (064).
- Fly the aircraft while the tone is steady and perform the landing approach as per the procedure in the landing tutorial.

Kobuleti Runway 07

- Magnetic Heading: 064**
(indicated on map)
- True Heading: 070**

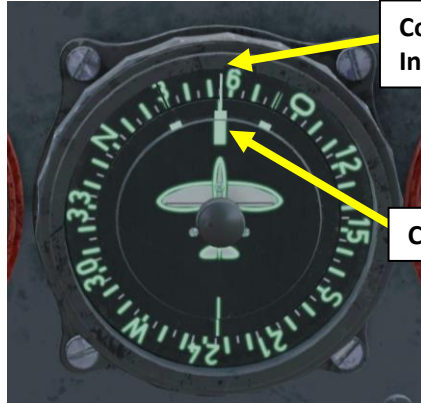
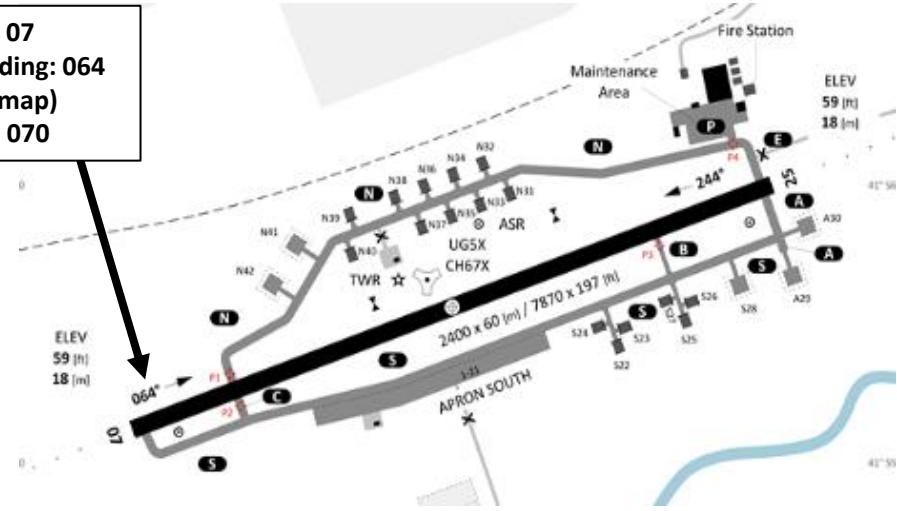

Course Reference Indicator (064)

Current Aircraft Heading

Aircraft flying in Both Left & Right Beams (aligned with runway centerline)

- Signal “Dits” and “Dahs” are both audible
- Both signals overlap, creating a steady signal tone.

Aircraft flying in Right Beam Only

- Signal “Dits” audible
- Signal “Dahs” not audible

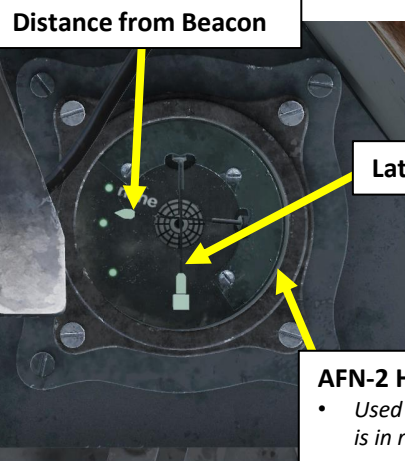

Distance from Beacon

Lateral Deviation

AFN-2 Homing Indicator

- Used to determine where aircraft is in relationship to airport.

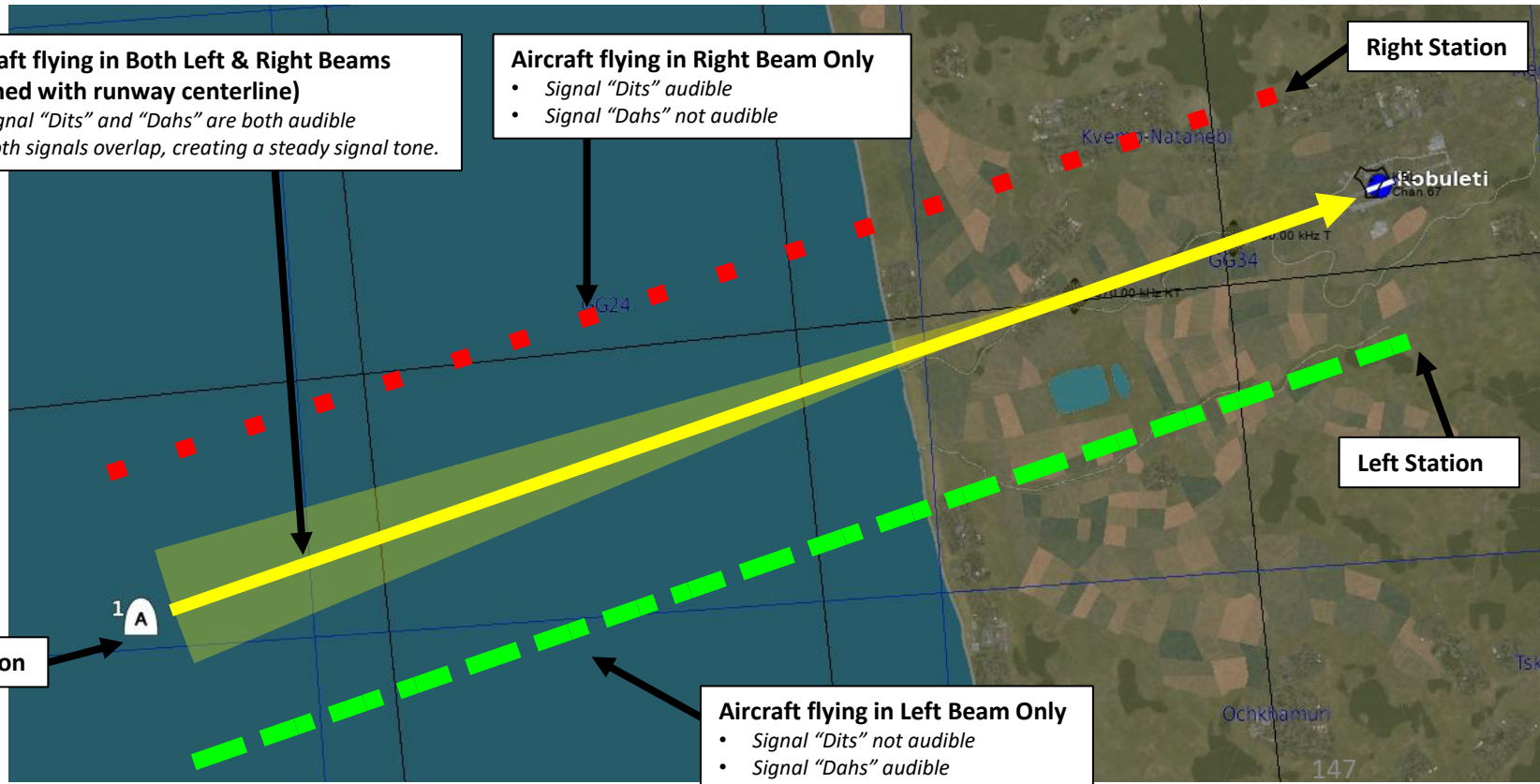

Right Station

Left Station

Aircraft Position

Aircraft flying in Left Beam Only

- Signal “Dits” not audible
- Signal “Dahs” audible

AFN-2 HOMING TUTORIAL (THEORY)

- In addition to the audio signal cues, you can use the AFN-2 Homing Indicator to help you navigate towards the airport. The AFN-2 provides both direction and range information.
 - The device has two moving bars that indicate homing beacon information. Each is similar to modern-day equipment, the VHF omnidirectional range – VOR – (vertical bar) and the distance measuring equipment – DME (horizontal bar).
 - The **vertical bar** indicates the **general direction** of the homing beacon in relation to the aircraft's nose.
 - The **horizontal bar** indicates the **distance** from the beacon. *(current axis is incorrectly reversed as of 2023/09/09)*
- When you are flying over a beacon, the Beacon/Marker Light should illuminate.

AFN-2 Homing Indicator

- Used to determine where aircraft is in relationship to airport.

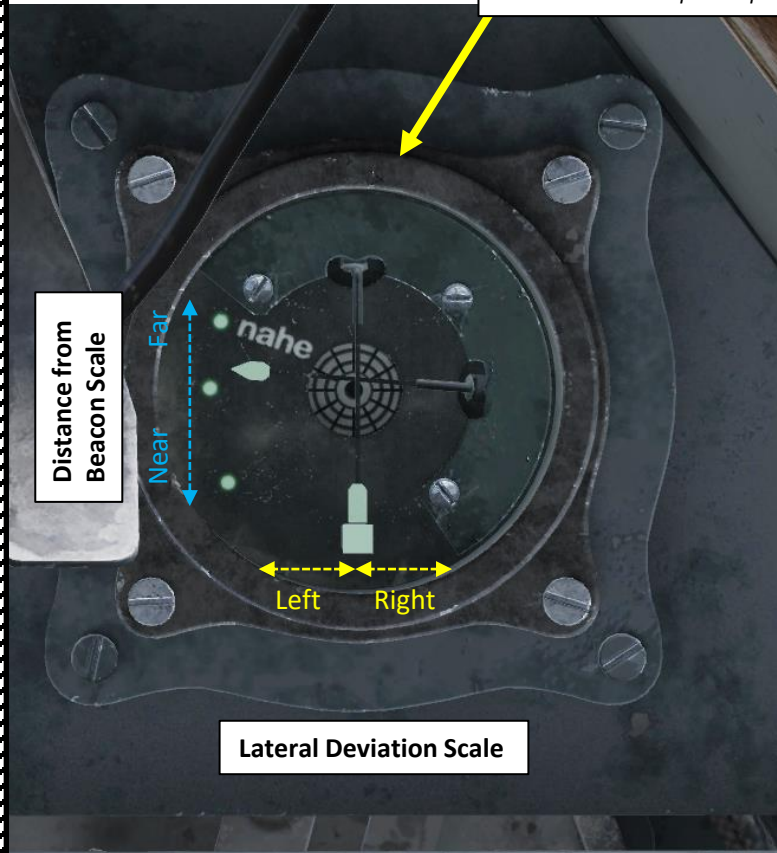

Distance from Beacon Scale

Far
Near

nahe

Left Right

Lateral Deviation Scale

Example: Aircraft is lined up with the runway, 3 km away.



Vertical Needle oscillates to the left

Example: Aircraft is left of the runway, 3 km away.

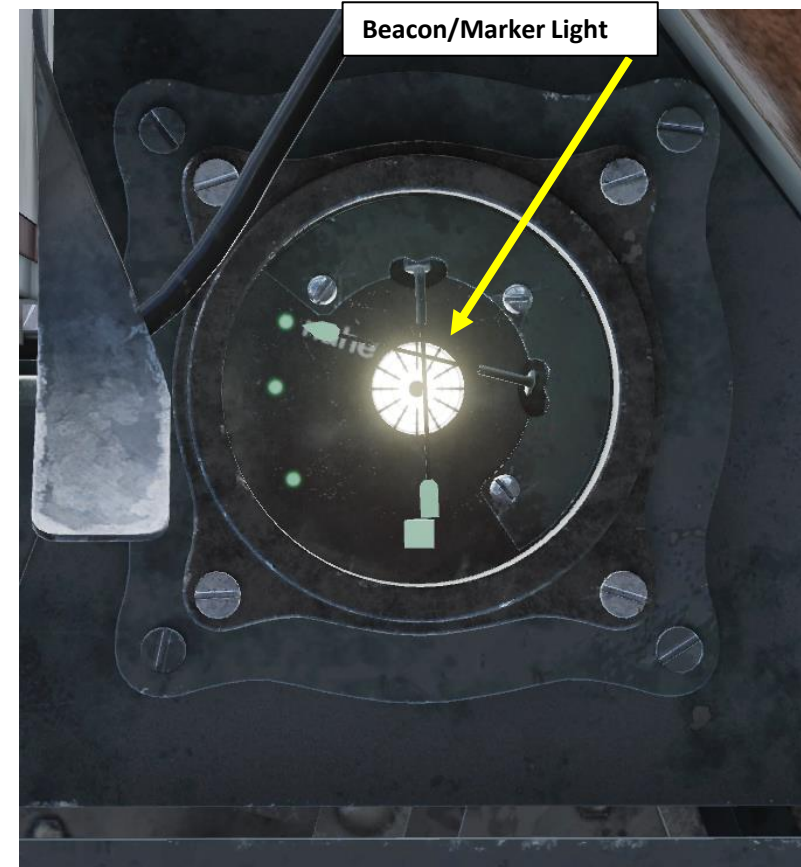

Beacon/Marker Light

AFN-2 HOMING TUTORIAL (THEORY)



MAGNETIC DECLINATION

The direction in which a compass needle points is known as magnetic north. In general, this is not exactly the direction of the North Magnetic Pole (or of any other consistent location). Instead, the compass aligns itself to the local geomagnetic field, which varies in a complex manner over the Earth's surface, as well as over time. The local angular difference between magnetic north and true north is called the magnetic declination. Most **map coordinate** systems are based on **true north**, and magnetic declination is often shown on map legends so that the direction of true north can be determined from north as indicated by a compass. This is the reason why in DCS, the course to a runway needs to be "adjusted" to take into account this magnetic declination of the magnetic North pole (which is actually modelled in the sim, which is pretty neat).

True Heading = Magnetic Heading + Magnetic Deviation

As an example, if the runway heading that you read on the F10 map in Azeville is 071 (True Heading), then the direction you should take with your magnetic compass course should be 071 subtracted with the Magnetic Deviation (-11 degrees), or 082. In other words, you would need to use a course of 082 (M) with your compass.

Magnetic Declination:

- -11 deg for Normandy in 1944
- -11 deg for the English Channel in 1944

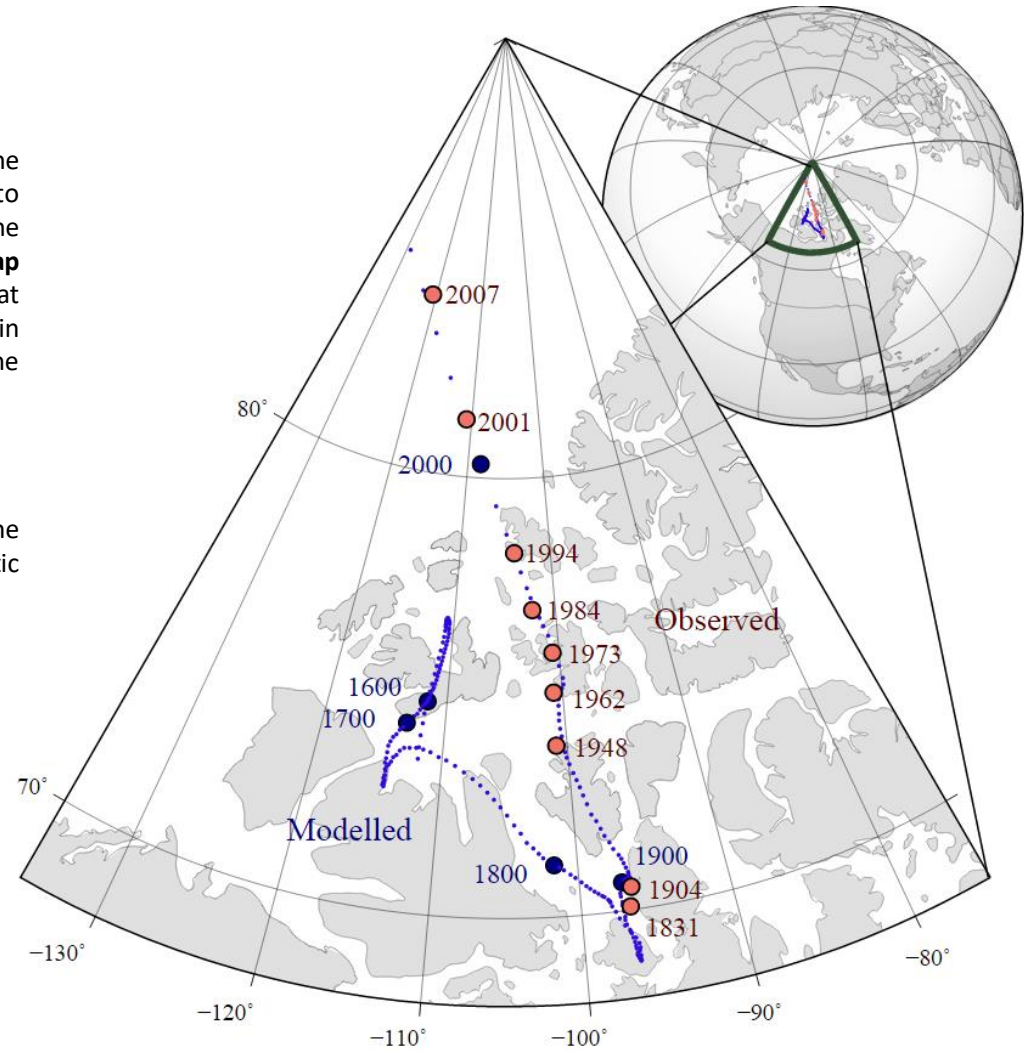

The movement of Earth's north magnetic pole across the Canadian arctic, 1831–2007.

Azeville	
ICAO	A-7
COALITION	RED
ELEVATION	74 ft
RWY Length	3549 ft
COORDINATES	49°28'46"N 01°19'29"W
TACAN	--
VOR	--
RSBN	--
ATC (MHz, AM)	3.925, 38.800, 118.350, 250.350
RWYs	7 25
ILS	-- --
PRMG	-- --
OUTER NDB	-- --
INNER NDB	-- --
RESOURCES	

MAGNETIC DECLINATION

Checking the magnetic declination is now very easy: you can access it directly from the F10 map, shown with the Compass Rose.

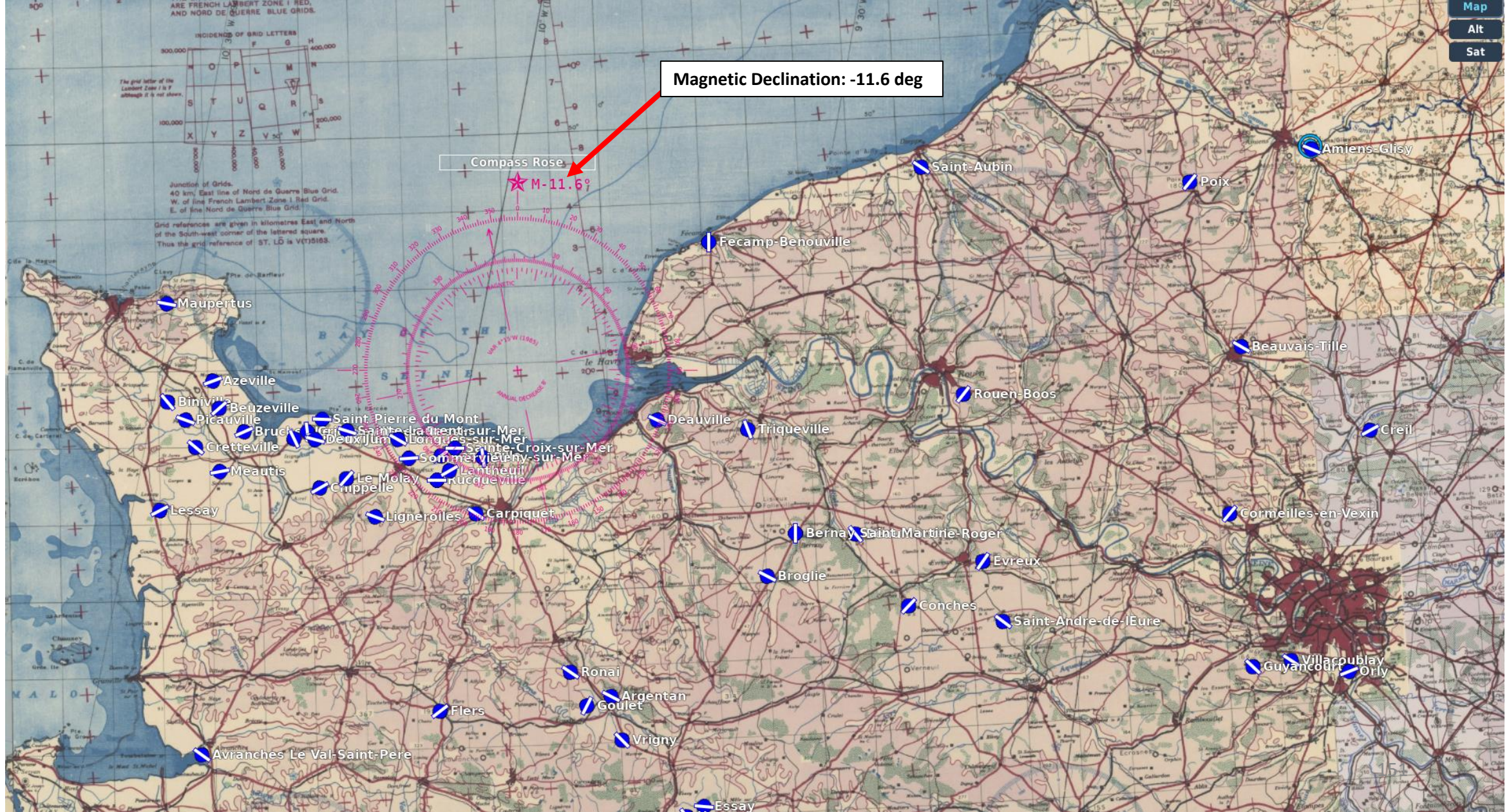

AIRPORT DATA NORMANDY 1944

By Minsky

<https://www.digitalcombatsimulat or.com/en/files/3312200/>

AD Normandy 2.0, Part 1

The magnetic headings below are valid from 1942 to 1950

DimOn

ID	England	ELEV. FEET METERS	VHF UHF	HF FM	MAG HDG / 3500 ft (1000m) OR LESS DOT - PRIMARY / LENGTH, feet / GRASS RWY	
71	Biggin Hill N51°19'38/.646 E00°01'57/.954	568 173	134.80 253.45	5.475 41.85	BROKEN SPAWNS	033° XX 4800 XX 213° 053° XX 2500 XX 233° 113° XX 2800 XX 293°
27	Chailey N50°57'08/.149 W00°02'50/.844	95 29	119.15 251.05	4.275 39.50		082° 07 4200 25 262° 161° ·15 3500 33·341°
54	Deanland N50°53'03/.059 E00°09'40/.680	72 22	120.60 252.50	5.000 40.95	RWY 34: HUGE BUMP	063° 22 3800 34 243°
73	Detling N51°18'20/.346 E00°36'05/.092	593 181	118.45 253.55	5.525 41.95		051° 04 3700 22 231°
52	Farnborough N51°16'43/.722 W00°46'28/.480	246 75	120.50 252.40	4.950 40.85	17 06	071° 06 4700 24 251° 116° 10 3000 28 296° 182° ·17 4000 35·002°
31	Ford N50°49'05/.085 W00°35'26/.443	29 9	119.40 251.30	4.400 39.75		067° 05 5600 23 247° 153° ·14 4500 32·333°
53	Friston N50°45'42/.704 E00°10'17/.289	309 94	120.55 252.45	4.975 40.90		069° 06 3700 24 249°
29	Funtington N50°52'05/.088 W00°52'08/.144	125 38	119.25 251.15	4.325 39.60		095° 08 6700 26 275° 160° ·15 5000 33·340°
66	Gravesend N51°25'04/.079 E00°23'48/.802	232 71	121.25 253.15	5.325 41.55	UNEVEN	187° 18 5000 36 007°
50	Heathrow N51°28'39/.657 W00°27'12/.216	89 27	CLOSED, NO ATC			098° 12 8700 30 278°
43	Kenley N51°18'14/.240 W00°05'47/.794	561 171	120.05 251.95	4.725 40.40	RWY 30: NO LAND	031° 02 3000 20 211° 131° ·02 2100 30·311°
37	Lymington N50°45'44/.748 W01°30'51/.863	20 6	119.70 251.60	4.550 40.05		068° 06 4200 24 248° 147° ·12 3500 30·327°
74	Lympne N51°04'58/.969 E01°01'10/.178	225 68	NO ATC			028° 02 3500 20 208° 119° ·07 3000 25·290°
72	Manston N51°20'32/.539 E01°20'46/.769	157 48	118.25 253.50	5.500 41.90		060° 05 5000 23 240° 107° ·XX 8700 XX·287°
28	Needs Oar Point N50°46'17/.299 W01°26'04/.071	20 6	119.20 251.10	4.300 39.55		071° ·06 4200 24·251° 180° 17 4700 35 000°
39	Odiham N51°14'03/.065 W00°56'30/.504	366 112	119.80 251.70	4.600 40.15		105° 10 5100 28 285°
58	Stoney Cross N50°54'40/.667 W01°39'29/.486	384 117	120.80 252.70	5.100 41.15		073° ·06 5800 24·253° 192° 18 4800 36 012°
30	Tangmere N50°50'44/.744 W00°42'06/.113	48 15	119.35 251.25	4.375 39.70		072° 06 5700 24 252° 162° ·03 4400 24·332°
41	West Malling N51°16'13/.221 E00°24'16/.281	305 93	119.95 251.85	4.675 40.30		074° ·15 5700 33 254°

DEG° MIN' SEC/.DCML

IMPROPERLY NAMED RUNWAYS ARE IN STRIKETHROUGH



Adjust the above magnetic headings when flying in the following years (expect 1-2 degrees of error):
 1935-1941 +1° 1951-1959 -1° 1960-1971 -2° 1972-1979 -3° 1980-1985 -4° 1986-1995 -5°
 1996-2001 -6° 2002-2009 -7° 2010-2016 -8° 2017-2020 -9° 2021-2026 -10°

AD Normandy 2.0, Part 2

The magnetic headings below are valid from 1942 to 1950

DimOn

ID	France A-Deauv	ELEV. FEET METERS	VHF UHF	HF FM	MAG HDG / 3500 ft (1000m) OR LESS DOT - PRIMARY / LENGTH, feet / GRASS RWY	
75	Abbeville Drucaat N50°08'16/.274 E01°50'17/.295	217 66	121.55 253.60	5.550 42.00		027° 02 5000 20 207° 093° 09 5000 27 273° 135° ·13 5200 31·315°
59	Amiens-Glisy N49°52'17/.290 E02°23'30/.513	216 66	120.85 252.75	5.125 38.40		049° 04 5100 22 229° 120° ·11 5100 29·300°
32	Argentan N48°46'07/.126 W00°01'49/.826	640 195	119.45 251.35	4.425 39.80		127° 12 3800 30 307°
65	Avranches Le Val-Saint-Pere N48°40'05/.091 W01°22'50/.837	47 14	121.20 253.10	5.300 41.50		137° 13 3800 31 317°
15	Azeville A-7 N49°28'51/.859 W01°19'03/.057	75 23	118.50 250.40	3.950 38.85		080° 07 3600 25 260°
34	Barville N48°28'48/.807 E00°18'50/.837	463 141	119.55 251.45	4.475 39.90		105° 10 4000 28 285° 156° ·15 4100 33·336°
20	Bazenville B-2 N49°18'14/.236 W00°33'53/.884	200 61	118.80 250.70	4.100 39.15		063° 05 5400 23 243°
67	Beaumont-le-Roger N49°05'46/.780 E00°47'48/.814	489 149	121.30 253.20	5.350 41.60		060° 04 2900 22 240° 092° 07 2400 25 272° 150° ·13 2600 31·330°
44	Beauvais-Tille N49°27'14/.249 E02°06'47/.792	331 101	120.10 252.00	4.750 40.45		046° 04 5500 22 226° 128° ·12 5300 30·308°
21	Beny-sur-Mer B-4 N49°17'52/.878 W00°25'35/.597	199 61	118.90 250.80	4.150 39.25		181° 17 4200 35 001°
69	Bernay Saint Martin N49°06'15/.264 E00°35'54/.905	512 156	121.40 253.30	5.400 41.70	MESH ISSUES	189° 18 3500 36 009°
14	Beuzeville A-6 N49°25'13/.231 W01°17'54/.913	114 35	118.40 250.35	3.925 38.80		059° 05 4300 23 239°
10	Binville A-24 N49°26'12/.202 W01°28'08/.138	107 32	118.15 250.15	3.825 38.60		150° 14 3500 32 330°
68	Broglie N49°00'56/.939 E00°29'55/.932	595 181	121.35 253.25	5.375 41.65		127° 12 3700 30 307°
5	Brucheville A-16 N49°22'06/.111 W01°12'58/.976	46 14	120.90 252.80	5.150 41.20		076° 07 4800 28 256°
19	Carpiquet B-17 N49°10'30/.507 W00°27'16/.268	187 57	118.70 250.60	4.050 39.05		133° 12 5100 30 313°
11	Cardonville A-3 N49°21'03/.060 W01°03'03/.060	102 31	118.20 250.20	3.850 38.65		164° 15 4800 33 344°
13	Chippelle A-5 N49°14'30/.513 W00°58'17/.299	125 38	118.35 250.30	3.900 38.75		070° 06 4900 24 250°
40	Conches N48°56'05/.086 E00°57'40/.676	541 165	119.90 251.80	4.650 40.25		052° 04 5100 22 232°
45	Cormeilles-en-Vexin N49°05'35/.594 E02°02'07/.124	312 95	120.15 252.05	4.775 40.50		048° ·04 5300 22·228° 122° 11 5200 29 302°
46	Creil N49°15'12/.208 E02°31'08/.136	269 82	120.20 252.10	4.800 40.55		069° ·15 7600 33·249° 138° 13 4000 31 318°
3	Cretteville A-14 N49°20'11/.194 W01°22'45/.761	95 29	119.85 251.75	4.625 40.20		140° 13 4800 31 320°
7	Cricqueville-en-Bessin A-2 N49°21'52/.872 W01°00'24/.414	81 25	121.70 253.75	5.625 42.15		183° 17 4900 35 003°
62	Deauville N49°21'51/.855 E00°09'26/.434	459 140	121.05 252.95	5.225 41.35	DAMAGED, LANDABLE	125° 12 3500 30 305°

IMPROPERLY NAMED RUNWAYS ARE IN STRIKETHROUGH

Adjust the above magnetic headings when flying in the following years (expect 1-2 degrees of error):
 1935-1941 +1° 1951-1959 -1° 1960-1971 -2° 1972-1979 -3° 1980-1985 -4° 1986-1995 -5°
 1996-2001 -6° 2002-2009 -7° 2010-2016 -8° 2017-2020 -9° 2021-2026 -10°

AIRPORT DATA

NORMANDY

1944

By Minsky
<https://www.digitalcombatsimulat.or.com/en/files/3312200/>

AD Normandy 2.0, Part 3

Average magvar: -9° (1944) / +1° (2023)
 The magnetic headings below are valid from 1942 to 1950

DimOn

ID	France	ELEV. FEET METERS	VHF HF UHF FM	MAG HDG / 3500ft (1000m) OR LESS DOT - PRIMARY / LENGTH, feet / GRASS RWY	
12	Deux Jumeaux A-4 N49°20'50/.838 W00°58'50/.849	124 38	118.30 250.25	3.875 38.70	115° 10 4800 28 295°
49	Dinan-Trelivan N48°26'36/.602 W02°06'11/.187	377 115	120.35 252.25	4.875 40.70	081° 07 2800 25 261°
35	Essay N48°31'14/.235 E00°15'27/.461	507 155	119.60 251.50	4.500 39.95	104° 09 3500 27 284°
26	Evreux N49°01'25/.426 E01°12'47/.789	423 129	119.10 251.00	4.250 39.45	044° 21 4800 35 224° 173° 16 5000 34 353°
51	Fecamp-Benouville N49°44'46/.776 E00°21'21/.365	295 90	120.45 252.35	4.925 40.80	189° 18 3600 36 009°
64	Flers N48°44'57/.952 W00°35'44/.737	661 202	121.15 253.05	5.275 41.45	BUMPY, UNEVEN 063° 05 3800 23 243°
33	Goulet N48°44'58/.979 W00°06'41/.688	617 188	119.50 251.40	4.450 39.85	036° 21 3700 35 216°
47	Guyancourt N48°45'31/.523 E02°04'47/.794	525 160	120.25 252.15	4.825 40.60	051° 04 2900 22 231° 082° 07 2400 25 262° 142° 13 2600 31 322°
36	Hauterive N48°29'59/.995 E00°12'00/.004	476 145	119.65 251.55	4.525 40.00	151° 15 3700 32 331°
25	Lantheuil B-9 N49°16'17/.286 W00°32'18/.304	175 53	119.05 250.95	4.225 39.40	070° 06 3800 24 250°
17	Le Molay A-9 N49°15'41/.691 W00°52'54/.900	105 32	118.60 250.50	4.000 38.95	051° 04 4400 22 231°
8	Lessay A-20 N49°12'05/.096 W01°30'07/.133	66 20	121.75 253.80	5.650 42.20	073° 06 4800 24 253° 134° 12 5800 30 314°
2	Lignerolles A-12 N49°10'30/.513 W00°47'21/.361	405 123	119.30 251.20	4.350 39.65	120° 11 4800 29 300°
18	Longues-sur-Mer B-11 N49°20'34/.573 W00°42'21/.357	225 69	118.65 250.55	4.025 39.00	130° 12 4300 30 310°
48	Lonrai N48°28'03/.060 E00°02'14/.242	515 157	120.30 252.20	4.850 40.65	069° 06 4700 24 249°
4	Maupertus A-15 N49°38'59/.987 W01°28'01/.017	441 134	120.40 252.30	4.900 40.75	111° 10 4800 28 291°
6	Meautis A-17 N49°16'59/.990 W01°18'00/.014	83 25	121.45 253.35	5.425 41.75	090° 08 4400 26 270°
77	Merville Calonne N50°37'13/.233 E02°39'12/.205	131 40	121.65 253.70	5.600 42.10	042° 03 4900 21 222° 082° XX 4900 XX 262° 145° 14 5100 32 325°
57	Orly N48°44'06/.108 E02°23'30/.508	272 83	120.75 252.65	5.075 41.10	022° 01 3600 19 202° 076° 07 3600 25 256°
16	Picauville A-8 N49°23'46/.782 W01°24'40/.669	73 22	118.55 250.45	3.975 38.90	120° 11 4400 29 300°
56	Poix N49°49'07/.130 E01°58'38/.636	547 167	120.70 252.60	5.050 41.05	047° 04 5100 22 227° 098° 09 5100 27 278°
60	Ronai N48°49'24/.403 W00°09'40/.673	860 262	120.95 252.85	5.175 41.25	083° 07 4100 25 263° 134° 12 4500 30 314°
61	Rouen-Boos N49°23'13/.232 E01°10'44/.737	493 150	121.00 252.90	5.200 41.30	047° 04 3500 22 227°
23	Rucqueville B-7 N49°15'05/.085 W00°34'49/.819	193 59	118.95 250.85	4.175 39.30	100° 09 4700 27 280°

IMPROPERLY NAMED RUNWAYS ARE IN STRIKETHROUGH

Adjust the above magnetic headings when flying in the following years (expect 1-2 degrees of error):
 1935-1941 +1° 1951-1959 -1° 1960-1971 -2° 1972-1979 -3° 1980-1985 -4° 1986-1995 -5°
 1996-2001 -6° 2002-2009 -7° 2010-2016 -8° 2017-2020 -9° 2021-2026 -10°

AD Normandy 2.0, Part 4

Average magvar: -9° (1944) / +1° (2023)
 The magnetic headings below are valid from 1942 to 1950

DimOn

ID	France	ELEV. FEET METERS	VHF HF UHF FM	MAG HDG / 3500ft (1000m) OR LESS DOT - PRIMARY / LENGTH, feet / GRASS RWY	
1	Saint Pierre du Mont A-1 N49°23'25/.430 W00°57'25/.425	103 31	118.75 250.65	4.075 39.10	102° 09 4900 27 282°
70	Saint-Andre-de-I Eure N48°53'28/.475 E01°16'05/.099	473 144	121.50 253.40	5.450 41.80	058° 05 5000 23 238° 136° 13 5000 31 316°
63	Saint-Aubin N49°53'06/.100 E01°04'/49.825	312 95	121.10 253.00	5.250 41.40	DAMAGED, LANDABLE 133° 12 3500 31 313°
76	Saint-Omer Wizernes N50°43'43/.729 E02°13'55/.932	213 65	121.60 253.65	5.575 42.05	039° 03 1700 21 219° 099° XX 2000 XX 279°
21	Sainte-Croix-sur-Mer B-3 N49°19'13/.216 W00°31'02/.035	160 49	118.85 250.75	4.125 39.20	100° 09 4500 27 280°
9	Sainte-Laurent-sur-Mer A-21 N49°21'52/.867 W00°52'24/.409	62 19	121.80 253.85	5.675 42.25	117° 11 4800 29 297°
24	Sommervieu B-8 N49°18'00/.013 W00°40'15/.257	187 57	119.00 250.90	4.200 39.35	096° 09 4500 27 276°
55	Triqueville N49°20'10/.172 E00°27'29/.496	404 123	120.65 252.55	5.025 41.00	168° 15 3800 34 348°
42	Villacoublay N48°46'02/.040 E02°12'18/.300	558 170	120.00 251.90	4.700 40.35	131° 12 3900 30 311°
38	Vrigny N48°40'20/.336 W00°00'07/.129	581 180	119.75 251.65	4.575 40.10	145° 14 3800 32 325°

IMPROPERLY NAMED RUNWAYS ARE IN STRIKETHROUGH

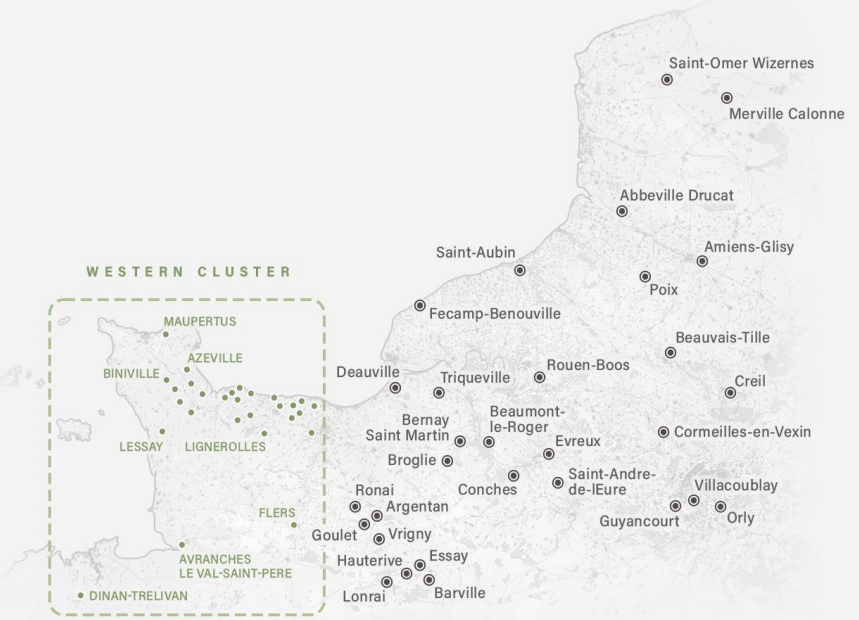

Adjust the above magnetic headings when flying in the following years (expect 1-2 degrees of error):
 1935-1941 +1° 1951-1959 -1° 1960-1971 -2° 1972-1979 -3° 1980-1985 -4° 1986-1995 -5°
 1996-2001 -6° 2002-2009 -7° 2010-2016 -8° 2017-2020 -9° 2021-2026 -10°

AIRPORT DATA NORMANDY 1944

By Minsky

<https://www.digitalcombatsimulator.com/en/files/3312200/>

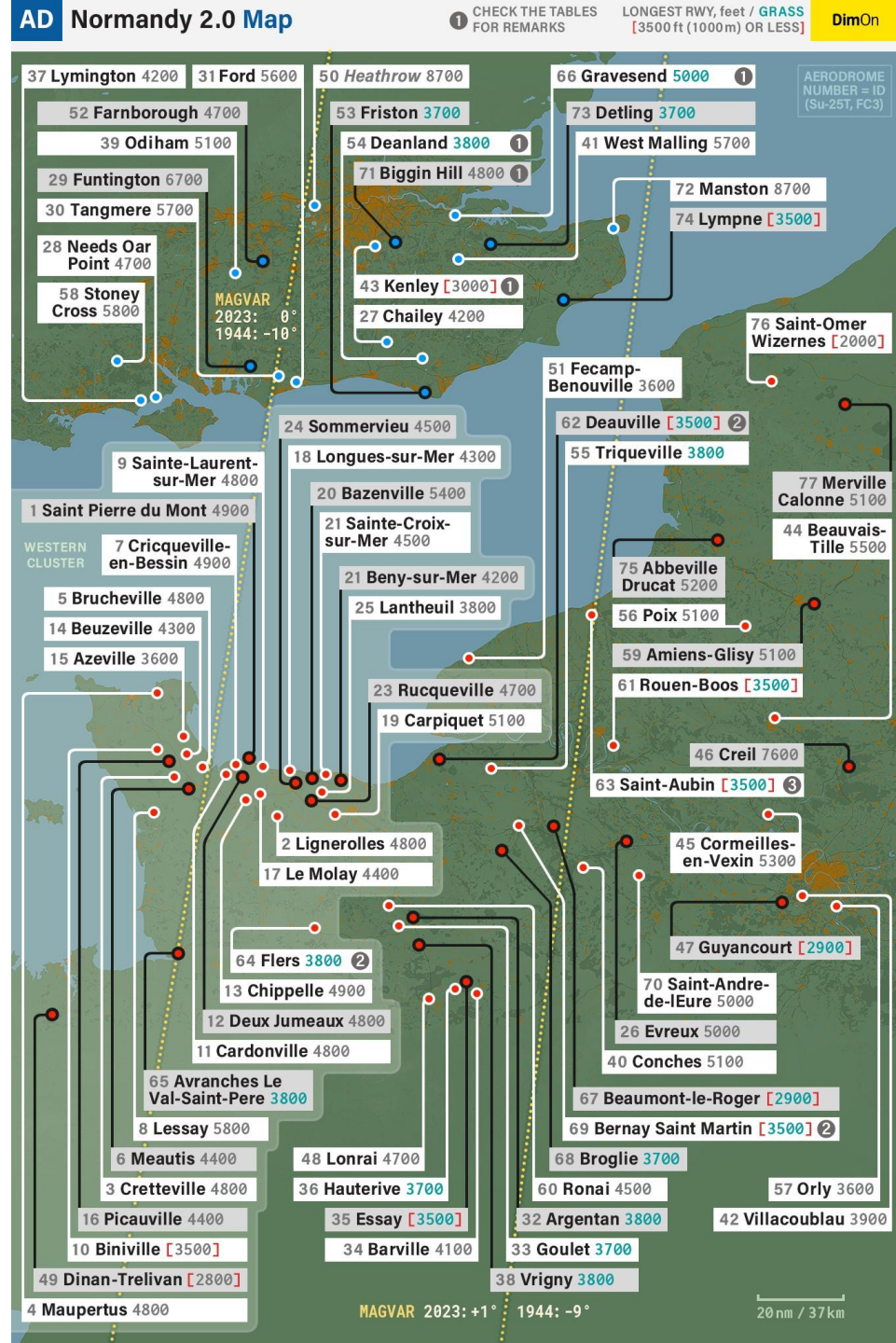

AIRPORT DATA ENGLISH CHANNEL 1944

By Minsky

<https://www.digitalcombatsimulat.or.com/en/files/3312200/>

AD The Channel

Average magvar: -11° (1944) / +1° (2023)
The magnetic headings below are valid from 1938 to 1950

ID	UK England	DEG° MIN' SEC' / DCML METERS	ELEV. FEET METERS	VHF HF UHF FM	MAG HDG / 3500 ft (1000m) OR LESS DOT - PRIMARY / LENGTH, feet / GRASS RWY
1	Biggin Hill N51°19'36' / .602 E00°01'51' / .866	553 169	118.20 3.850 250.20 38.60	040° 04 4700 22 220° 059° 05 2300 23 239° 119° 12 2500 30 299°	
8	Detling N51°18'18' / .302 E00°35'59' / .991	623 190	118.60 4.050 250.60 39.00	058° 05 3700 23 238°	
9	Eastchurch N51°23'24' / .408 E00°50'48' / .814	40 13	118.05 3.775 250.05 38.45	034° 02 3100 20 214° 109° 10 3500 28 289°	
6	Hawkinge N51°06'42' / .714 E01°09'36' / .615	525 160	118.50 4.000 250.50 38.90	011° 01 2500 19 191° 050° 05 3100 23 230°	
11	Headcorn N51°10'57' / .956 E00°41'22' / .369	115 35	118.15 3.825 250.15 38.55	024° 02 3800 20 204° 104° 10 4100 29 284°	
10	High Halden N51°07'17' / .298 E00°41'37' / .624	105 32	118.10 3.800 250.10 38.50	042° 04 4300 22 222° 113° 11 3900 29 293°	
7	Lympne N51°04'50' / .839 E01°01'01' / .022	351 107	118.55 4.025 250.55 38.95	031° 02 2600 20 211° 145° 13 3200 31 325° 169° 16 3500 34 349°	
5	Manston N51°20'31' / .518 E01°20'46' / .768	161 50	118.45 3.975 250.45 38.85	067° 04 4800 22 247° 113° 10 9000 28 293°	

France

1	Abbeville Drucat N50°08'36' / .607 E01°49'55' / .916	184 56	118.25 3.875 250.25 38.65	034° 02 5100 20 214° 100° 09 5100 27 280° 142° 13 5100 31 322°	
4	Dunkirk Mardyck N51°01'46' / .777 E02°15'08' / .147	16 5	118.40 3.950 250.40 38.80	091° 08 2000 26 271°	
2	Merville Calonne N50°37'10' / .170 E02°38'17' / .287	52 16	118.30 3.900 250.30 38.70	048° 04 5100 22 228° 088° 08 5100 26 268° 149° 14 5000 32 329°	
3	Saint Omer Longuenesse N50°43'43' / .721 E02°13'54' / .915	220 67	118.35 3.925 250.35 38.75	040° 03 1600 21 220° 097° 08 2000 26 277°	

IMPROPERLY NAMED RUNWAYS ARE IN STRIKETHROUGH



Adjust the above magnetic headings when flying in the following years (expect about 1 degree of error):
 1951-1954 -1° 1955-1961 -2° 1962-1967 -3° 1968-1972 -4° 1973-1979 -5° 1980-1987 -6°
 1988-1995 -7° 1996-2001 -8° 2002-2009 -9° 2010-2015 -10° 2016-2021 -11° 2022-2026 -12°

AD The Channel Map

RUNWAY LENGTH, feet / GRASS [3500 ft (1000m) OR LESS] DimOn

The magnetic headings below are valid from 1938 to 1950

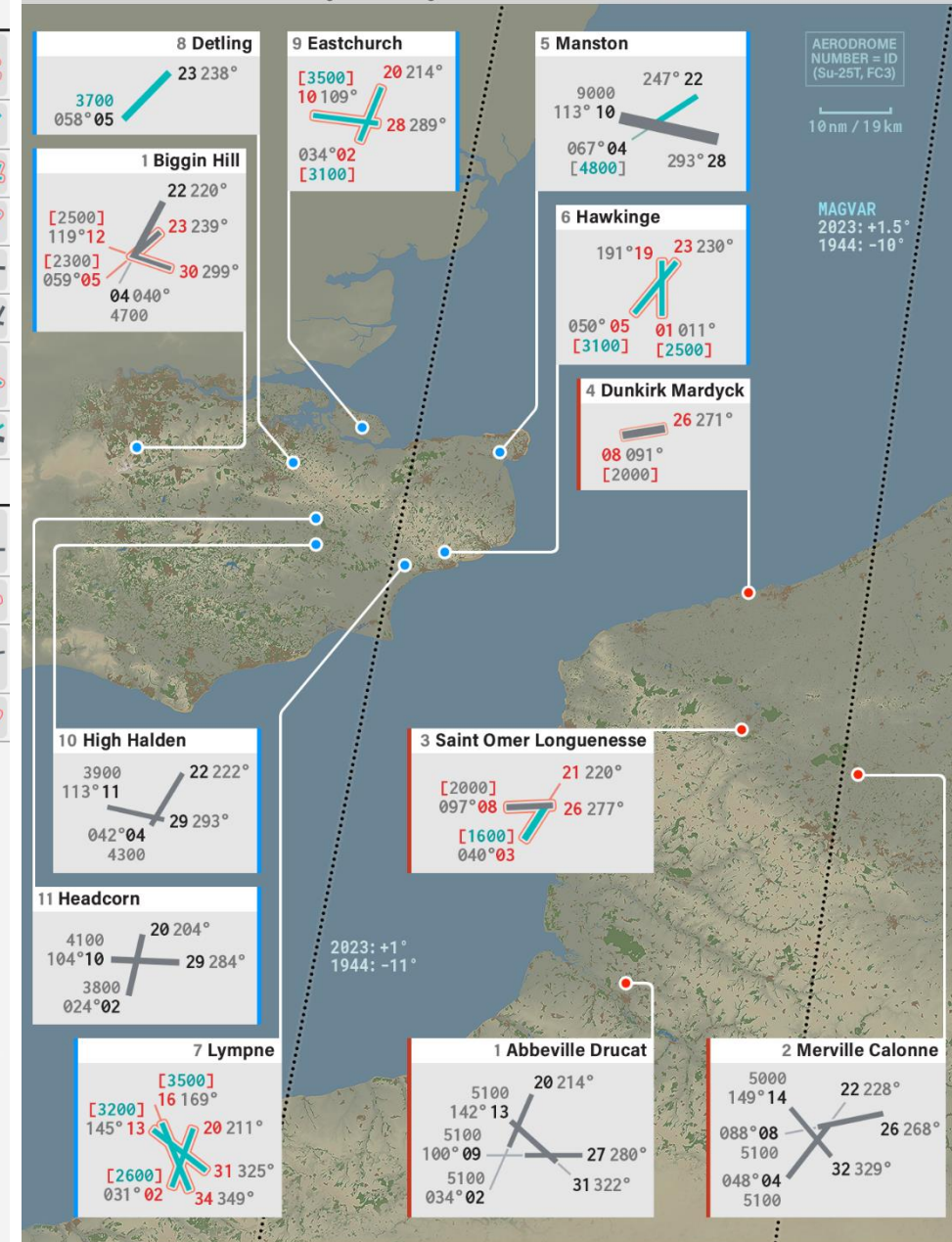

Adjust the above magnetic headings when flying in the following years (expect about 1 degree of error):
 1951-1954 -1° 1955-1961 -2° 1962-1967 -3° 1968-1972 -4° 1973-1979 -5° 1980-1987 -6°
 1988-1995 -7° 1996-2001 -8° 2002-2009 -9° 2010-2015 -10° 2016-2021 -11° 2022-2026 -12°

AIR COMBAT TIPS

The FW190A-8 variant modelled in DCS is one of the deadliest WWII fighters when flown properly. In comparison to the FW190D-9 “Dora”, the FW190-A8 “Anton” has a much higher firepower and can easily take care of incoming B-17 bombers.

The way to fly a FW190 is pretty much the same in every simulator: keep your energy state high (meaning that you must keep your airspeed and your altitude up) at all times and avoid turning with an enemy fighter that turns hard to try to make you bleed your energy.

The 190 is first and foremost an energy fighter. In combat, a pilot is faced with a variety of limiting factors. Some limitations are constant such as gravity, drag, and thrust-to-weight-ratio. Other limitations vary with speed and altitude, such as turn radius, turn rate, and the specific energy of the aircraft. The fighter pilot uses BFM (Basic Flight Manoeuvres) to turn these limitations into tactical advantages. A faster, heavier aircraft may not be able to evade a more maneuverable aircraft in a turning battle (like the Spitfire), but can often choose to break off the fight and escape by diving or using its thrust to provide a speed advantage. A lighter, more maneuverable aircraft can not usually choose to escape, but must use its smaller turning radius at higher speeds to evade the attacker's guns, and to try to circle around behind the attacker. This is the principle behind “energy fighting”: use boom and zoom tactics instead of trying to turn with an enemy aircraft that has a smaller turn radius.

The 190 has a high power-to-weight ratio, meaning that it has a good acceleration. It is equally quite manoeuvrable, but I would recommend avoiding dogfights above 20,000 ft (6 km) since this is where the Mustang has the advantage.



ADVICE ON HOW TO FLY TAILDRAGGER AIRCRAFT

Taming taildraggers is much more difficult than meets the eye, especially during the takeoff and landing phase. Here is a useful and insightful essay on the art of flying taildraggers wonderfully written by *Chief Instructor*. I highly recommend you give it a read.

Link: <https://drive.google.com/open?id=0B-uSpZROuEd3V3Jkd2pfa0xRRW8>

TAMING TAILDRAGGERS

Essay by Chief Instructor (CFI)

PART 1

Why taildraggers are tricky and how to overcome it

What do I know about it? Well, I have spent a significant proportion of my professional flying career teaching both experienced and novice pilots how to fly and handle tail-dragging aircraft. This amounts to several thousand hours of tailwheel training alone, though who's counting! These aircraft include among them modern high performance aerobatic aircraft and a variety of more vintage types from DH Tiger Moths, to Harvards. I can't recall off the top of my head exactly how many students I've worked with over the years, but it's well over 200! Best of all, they have all gone on to fly extensive tailwheel ops in a variety of types and to the best of my knowledge, only 2 of them have crashed anything since!

As a significant number of pilots here are expressing difficulties with tailwheel handling,



Fw190A-8



- INSTANT ACTION
- CREATE FAST MISSION
- MISSION
- CAMPAIGN
- MULTIPLAYER

- LOGBOOK
- ENCYCLOPEDIA
- TRAINING
- REPLAY

- MISSION EDITOR
- CAMPAIGN BUILDER

EXIT



Nevada
2.5.0



A-10C



AJS37



AV8B
NIGHT ATTACK



Bf 109 K-4



C-101
Beta



CA



Caucasus



Christen
Eagle II



F-14B
EA



F-5E



F-86F



F/A-18C
EA



FC3



Fw 190 A-8
EA



Fw 190 D-9



I-16
Beta